



Non Half Hourly Data Aggregation (NHHDA) System Management Guide

Version Number 18.03

DRAFT

DRAFT

Non Half Hourly Data Aggregation (NHHDA) System Management Guide

Status : ~~Final~~Draft

Version : 18.03

Date : ~~27 June 2013~~6 November 2014

Prepared by : Cognizant

Approved by (Cognizant) : Project Manager

DRAFT

Table Of Contents

1	Introduction	5
1.1	Purpose	5
1.2	Scope	5
1.3	Structure of Document.....	5
1.4	Amendment History	6
1.5	Summary of Changes.....	9
1.6	Changes Forecast	9
1.7	References	9
1.8	Abbreviations.....	109
1.9	Intellectual Property Rights and Copyright	11
2	Overview of the System.....	12
2.1	Users of the System	12
2.2	Data Interfaces	13
3	System Structure	14
3.1	Aggregation Run (NAR) Subsystem	14
3.2	Check Data Collector Data (NCD) Subsystem.....	15
3.3	Manage Instructions (NMI) Subsystem.....	16
3.4	Load Data File (NLD) Subsystem	17
3.5	File Receipt Manager (CFR) Subsystem	18
3.6	Scheduler (CSC) Subsystem.....	18
3.7	Logging (CLG) Subsystem.....	19
3.8	File Sender (CFS) Subsystem	19
3.9	Report Display (CRP) Subsystem	20
3.10	User Administration (NUA) Subsystem.....	20
3.11	EAC Data for Distributor (NDP) Subsystem	20
4	Application Environment	22
4.1	Hardware	22
4.2	Software.....	24
4.3	Configuration Management Procedures	26
4.3.1	Introduction.....	26
4.3.2	Build and Release numbers.....	27
4.3.3	Deliverables maintained under Configuration Control.....	28
4.3.4	Compatibility of Deliverable Products	29
4.4	External Support	30
4.5	Schedule of Activities.....	31
5	Database Organisation.....	32
5.1	Database Tables	32
5.2	Partitions.....	35
5.3	Tablespaces.....	36
5.4	Timestamps.....	37
5.5	Domains.....	37
5.6	Database Sizing	45
5.7	Physical Organisation (Tablespaces/Files).....	45
5.8	Oracle Parameters.....	46

5.9	Oracle Object Storage Parameters	46
5.10	Oracle Performance Tuning : Optimiser Statistics.....	47
6	System Organisation.....	48
6.1	Directory Structure.....	48
6.2	File Names	49
6.3	File Locations.....	50
6.4	Receiving files - cdb_file_processing	52
6.5	Sending files - cdb_export_configuration.....	53
6.6	File Sizing	54
6.7	Configuring Temporary Files.....	55
6.8	Batch Queues	55
6.9	Locations of Aggregation Intermediate Files.....	57
6.10	NHHDA Processes.....	57
7	System Parameters.....	59
8	User Accounts, Privileges and Security	6564
8.1	Server Operating System.....	6564
8.2	Oracle Database Tables.....	6665
8.3	Oracle Forms access.....	6766
8.4	Password Management Through Oracle Profile	6766
8.5	Maintain User.....	6766
8.6	Breaches of security	6867
9	Auditing	6968
9.1	Audit Database Tables	6968
9.2	Audit Log Files	7069
9.3	Auditing of Data Aggregation Runs	7271
10	Starting Up and Shutting Down the System.....	7473
10.1	Starting the System	7473
10.2	Shutting Down the System.....	7574
11	Monitoring the System	7675
11.1	Operator and Error Logs	7675
11.2	Scheduler Logs.....	7776
11.3	Audit Logs.....	7776
11.4	Aggregation Exception Log File.....	7877
11.5	Aggregation Run Log.....	7877
11.6	Data Collector Exception Log.....	7877
11.7	Load MDD Exception Log.....	7877
11.8	Load Data Aggregation and Settlement Timetable File Exceptions Log.....	7877
11.9	Directories	7978
11.10	File Receipt and File Send Logs	7978
11.11	EAC Data To Distributor Exception Logs	7978
12	Archiving	8079
12.1	Archiving Operating System Files	8079
12.1.1	Archive the Files to the Archive Directory	8281
12.1.2	Copy Files to Archive Media	8281

12.1.3	Record the Archive Media of the Files.....	<u>8382</u>
12.1.4	Record the removal of the files from Archive Directory.....	<u>8382</u>
12.2	Archiving Database Data.....	<u>8382</u>
12.2.1	Database Archive Criteria	<u>8483</u>
12.2.2	Back Up Database Data	<u>8786</u>
12.2.3	Archive Database Data	<u>8786</u>
12.3	Archiving of Instruction Data – Archive Groups ‘FIN’ and ‘FIS’	<u>8786</u>
12.4	Restoring Operating System Files	<u>8887</u>
12.5	Archiving of Instruction Data – Archive Groups ‘FIN’ and ‘FIS’	<u>8887</u>
12.6	Restoring Database Data	<u>9089</u>
13	Backup and Recovery	<u>9190</u>
13.1	Guidelines on Backup Policy	<u>9190</u>
13.2	Checkpointing.....	<u>9190</u>
13.3	Daily Off-line Backups of the NHHDA Database	<u>9190</u>
13.4	Daily Backups of the NHHDA File Store	<u>9291</u>
13.5	Backup Prior to Refresh of the Database.....	<u>9291</u>
13.6	Restoration for Recovery.....	<u>9392</u>
13.6.1	Recovery from Power Failure.....	<u>9392</u>
13.6.2	Recovery from Fatal Errors	<u>9392</u>
13.6.3	Recovery from Media (disk) Failure	<u>9392</u>
13.6.4	Recovery from Activity Status Tracking Problems.....	<u>9594</u>
13.6.5	Disaster Recovery.....	<u>9695</u>
13.6.6	Recovery of temporary tables.....	<u>9695</u>
13.7	Restoration for Auditing.....	<u>9695</u>
14	PRS Refresh	<u>9796</u>
14.1	Pre-requisites to the Application of a Refresh Instruction	<u>9796</u>
14.2	Logs Containing Information Relating to the Refresh Process	<u>9897</u>
14.2.1	Changes made to ndb_registrations table	<u>9897</u>
14.2.2	Changes made to ndb_data_agg_apps	<u>9897</u>
14.2.3	Changes made to ndb_ms_prs_dets.....	<u>9897</u>
14.2.4	Changes to ndb_dc_apps	<u>9998</u>
14.2.5	Instruction Failure Reasons	<u>9998</u>
14.2.6	Summary Report.....	<u>9998</u>
14.3	Action to take after the Refresh completed	<u>10099</u>
14.3.1	Refresh status is "Applied"	<u>10099</u>
14.3.2	Refresh status is "Validation Errors"	<u>10099</u>
14.3.3	Refresh status is "Discarded".....	<u>10099</u>
14.4	Manage Refresh Instruction Failure	<u>101400</u>
14.5	Restarting the NHHDA Application Software After Refresh	<u>102401</u>
15	System Management of Application Server.....	<u>103102</u>
15.1	Remove the Old Report Files	<u>103402</u>
Appendix A	Application Error Messages	<u>104103</u>
A.1	Error Log Messages.....	<u>104103</u>
A.1.1	Data Aggregation	<u>104103</u>
A.1.2	Check Data Collector Data	<u>106405</u>
A.1.3	Instruction Processing.....	<u>108407</u>
A.1.4	Data Loading.....	<u>109408</u>

1 Introduction

This document is the System Management Guide for the NHHDA application software developed for ELEXON.

Software Version

This version of the NHHDA System Management Guide is applicable to the environment of release 11.0.0 of the NHHDA application software.

1.1 Purpose

The purpose of this System Management Guide is to provide information that will enable the NHHDA System Manager to support system operation.

1.2 Scope

The NHHDA application software is the central component of an operational system. The recipient organisation needs to build operational procedures around the application software that will meet the needs of its users and complement other aspects of the organisation's operational environment. Organisations need to comply with Agreed Procedures and Service Lines.

The scope of this guide covers the system management aspects of the NHHDA application software, such as system structure, directories and file names, database organisation, archive and restoration of data, audit logs, and guidelines on backup and recovery. Detail pertaining to hardware and third party software is included only where necessary to support the description of the NHHDA application software. The sites running the NHHDA application software are expected to have expertise in the setting up and day to day management of the server system, and an Oracle Database Administrator to carry out the housekeeping tasks for a large relational database.

For operational aspects of the NHHDA application software, refer to the NHHDA Operations Guide.

For details of installation of the NHHDA application software, refer to the corresponding Installation Guide.

Comments on the completeness and accuracy of this guide are welcome. A Comment Form is contained at the back of this guide.

1.3 Structure of Document

The remainder of this document consists of the following sections:

- Section 2 gives an overview of the NHHDA system;
- Section 3 describes the system structure in terms of its subsystems;
- Section 4 outlines the hardware and software environment, configuration management, external support for the application software, and outlines tasks that should be included in a schedule for supporting the application environment;
- Section 5 shows the organisation of the NHHDA database;
- Section 6 describes the organisation of the NHHDA system;

- Section 7 describes the system parameters used by the system;
- Section 8 provides information on system security;
- Section 9 describes the functionality provided for auditing;
- Section 10 describes how to start up and shut down the system;
- Section 11 describes the facilities available for monitoring the system;
- Section 12 discusses archive and restore facilities;
- Section 13 outlines backup and recovery functionality.

Appendices to this document are as follows:

- Appendix A lists the application messages that are contained in exception logs

1.4 Amendment History

Version	Details
0.901	First draft issue to Client
0.902	Addressing highest priority comments
0.903	Addressing severity 1 and 2 comments
0.990	Addressing outstanding and additional comments
1.000	Authorised version
1.100	Incorporating updates to Archiving as per OR 2248 OR2353 LCR080/CR422 Changed Settlement Code from 'D_' to 'DR' OR2351 LCR075/CR455 Refresh unit of work is not Metering System OR2366 add details of cdb_export_configuration spelling checked and corrected OR2369 LCR082/CR492 Instruction processing performance changes
1.200	OR2444 (LCR092, CR487) Average EAC changed to Default EAC in documentation only OR2248 (Pool Defects 1427, 1429, 1430, 1434, 1435, 1436, 1437, 1438, 1440, 1442, 1444) Archive rules updated to match NTSPEC
1.500	Include internal review comments. Pool defect 818 (CR 94) Issue for external review
2.000	Apply Pool review comments consistent with software version 1.3 Authorised version
2.001	OR2721 Auto-processing of files clarification PMR0132/OR2729 Added information on the configuration of temporary files. OR2765 Handling the 'unknown' activity status
2.002	Incorporating changes from TA2000 development The changes are detailed in the following SIRs: (Package 1) LCRs 21/3 (SIR R419), 106 (SIR R576) ,

Version	Details
	114 (SIR R654) and divergence document 001ldr30.doc. (Package 2/MDD) LCRs 94/2 (SIR R529), 103/2 (SIR R709), 105 (SIR R391), 107 (SIR R692), 109 (SIR R715), 110 (SIR R716), 112 (SIR R575), 116 (SIR R991), 124/2 (SIR R295), 127/2 (SIR 1528) and divergence document 002ldr50.doc.
2.990	Incorporating internal review comments.
2.991	Incorporating Pool comments.
3.000	Incorporating Pool review comments consistent with release 4.0.0/5.0.0 Authorised Version
3.001	Incorporating the following Ors: OR2892 – Modification types for audit logs listed incorrectly in section 9.2 OR2925 – Section 6.3 incorrectly states that L039s will be removed by archiving
3.002	Incorporating changes for LCR149/2.
3.990	Removed references to release 4 functionality Issued to Pool for review.
4.000	Authorised Version.
4.001	Incorporating LCR170/2 – Upgrade to Oracle 8i and Oracle Forms 6. Incorporating OR 3010, adding new exceptions.
4.990	Issued to Pool for review.
5.000	Authorised version.
5.001	Update for Oracle 8.1.7 upgrade. Incorporating OR 3096, OR3097- adding missing codes.
5.990	Issued to Pool for review.
5.991	Incorporating Pool review comments, OR3118 – Updating the copyright notice
5.992	OR3120 – Updating the Oracle version number.
5.993	Change to Office 2000
5.994	Changes relating to ELEXON superseding the Electricity Pool.
6.000	Amended month on cover to May 2000 and made definitive
6.001	Incorporating OR 3200 – some suggested improvements.
6.002	Changes for OR2961 and OR3015
6.990	Version for ELEXON review
6.991	Incorporating ELEXON review comments
6.992	Incorporating ELEXON review comments
7.000	Made definitive
7.001	Changes for P62
7.002	Incorporating OR 3306

Version	Details
7.003	Changes for LCR215/3
7.004	Update template (including addition of Abbreviations section)
7.990	Version for ELEXON review
7.991	Update after ELEXON review.
8.000	Authorised version
8.001	Changes for LCR225 (Oracle 9i Upgrade) Document Template updated
8.990	Version for ELEXON review
9.000	Authorised version
9.001	Changes for LCRA218/4 NHHDA BETTA changes
9.990	Version for ELEXON review
9.991	Applied ELEXON review comments
10.000	Authorised version
11.000	Updated document references
11.001	Updated with LCR220.
11.002	Updated after internal review.
11.003	Applied ELEXON review comments
11.004	Amendments for Nov. '04 release begin. (CP1001, CP1006, CP1016 & CP1052). Issued to ELEXON for review.
11.005	Further revisions as a result of ELEXON comments. Issued to ELEXON for review.
11.006	Additional amendments as a result of ELEXON comments. Issued to ELEXON for review.
11.007	Additional entity to store numbers of refresh instructions
11.008	Final updates included. Issued to ELEXON.
12.000	Authorised version.
12.990	Incorporated DCRs for Feb06 release (CP933, CP965, CP1047 & CP1089). Version for ELEXON review.
13.000	Authorised version.
13.001	Incorporating changes for OR3581
13.002	Draft for Internal review for Nov.06 release, including Oracle upgrade to 10g on 2-Tier & 3-Tier Architecture
13.003	Incorporated Internal review comments for Nov.06 release.
13.004	Further changes for November 06 release.- OR3633 OR 3634, OR3661/HD061732
13.990	Version for ELEXON review
13.991	Incorporating review comments
14.000	Authorised version
14.001	Added additional performance tuning information

Version	Details
14.002	Incorporating review comments
14.100	Authorised Nov 06 release final version
14.900	Updated for Feb 08 Release: CP1187; OR3716 HD063951 ; OR3659 HD064195
14.990	Incorporating internal review comments ; version for ELEXON review
15.000	Authorised version
15.900	Incorporating changes for Feb 09 release.
15.901	Incorporate ELEXON review comments and internal review comments.
16.000	Authorised version
16.010	Updated document classification
16.0	Back issued for exit management
16.1	November 11 Release: P253
16.2	P253: Updated with Elexon Review comments
16.5	Updated review comments for November 11 Release: P253
17.0	P253: Final version
18.0	CP1383 - Updated for Tech Upgrade (Oracle DB upgrade from 10.2.0.3 to 11.2.0.3 and OAS upgrade from 10.1.2.2 to 11.1.1.6)
18.1	Updated for CP1408 implementation to include the boundary value validation for EAC and AA values
18.2	Incorporated the ELEXON's review comments
18.3	Incorporated the ELEXON's further review comments

1.5 Summary of Changes

Changes as indicated in the amendment history.

1.6 Changes Forecast

Agreed Change Requests will be incorporated.

1.7 References

Mnemonic	Information	Details
[NOPSGDE]	Title: Author:	NHHDA Operations Guide. Cognizant
[NINGDE]	Title: Author:	NHHDA Installation Guide. Cognizant
[NTSPEC]	Title: Author:	NHHDA Physical Design Technical Specification Cognizant
[CTSPEC]	Title: Author:	Common Subsystems Technical Specification Cognizant
[DIS]	Title: Author:	SVA Data Catalogue Volume 1: Data Interfaces ELEXON
[ORATUN]	Title: Author:	Oracle Database Performance Tuning Guide 10g Oracle Corporation

1.8 Abbreviations

AA	Annualised Advance
AFYC	Average Fraction of Yearly Consumption
BETTA	British Electricity Transmission and Trading Arrangements
Helpdesk	Service help desk maintained by ELEXON. Can be contacted through bscservicedesk@logica.com or 0870 010 6950
CBO	Cost Based Optimiserr
C2.0	Configuration Management tool used by Cognizant for documents
SVN	Configuration Management tool used by Cognizant for Source code (Tortoise Sub version)
DAA	Data Aggregator Appointment
DC	Data Collector
DCP	DC Performance (Report)
EAC	Estimation of Annual Consumption
ES	Energisation Status
GSP	Grid Supply Point
ISRA	Initial Settlement and Reconciliation Agency (now called SVAA)
LDSO	Licensed Distribution System Operator
LLFC	Line Loss Factor Class
MAP	Meter Advance Period
MC	Measurement Class
MDD	Market Domain Data
NHHDA	Non Half Hourly Data Aggregator
PC	Profile Class
PRS	PES Registration Service (now called SMRA)
SMRA	Supplier Meter Registration Agent
SPM	Supplier Purchase Matrix
SSC	Standard Settlement Configuration
SVAA	Supplier Volume Allocation Agent
SVACSS	Supplier Volume Allocation Core Systems Support

1.9 Intellectual Property Rights and Copyright

The copyright and other intellectual property rights in this document are vested in ELEXON. These materials are made available to participants in the GB electricity industry to review and copy for the sole purpose of their participation in the electricity industry. All other commercial use is prohibited including downloading, copying, distributing, modifying, transmitting, publishing, selling or creating derivative works (in whatever format) from this document or in other cases use for personal academic or other non-commercial purposes. All copyright and other proprietary notices contained in the document must be retained on any copy you make.

All other rights of the copyright owner not expressly dealt with above are reserved.

No representation, warranty or guarantee is made that the information in this document is accurate or complete. While care is taken in the collection and provision of this information, ELEXON Limited shall not be liable for any errors, omissions, misstatements or mistakes in any information or damages resulting from the use of this information or action taken in reliance on it.

DRAFT

2 Overview of the System

The Non Half Hourly Data Aggregation (NHHDA) system is responsible for carrying out aggregations of actual readings and predicted usage for metering systems. PRS Agents send Metering System data to the NHHDA system, in the form of Instructions. Data Collectors also send Metering System data, and Estimations of Annual Consumption (EACs) and Annualised Advances (AAs), as Instructions.

Using the Metering System data supplied by the PRS Agents, and the EACs and AAs supplied by the Data Collectors, the NHHDA system performs an aggregation for each Interim Information, Initial Settlement and Reconciliation, according to the Settlement Timetable received from the Market Domain Data Agent. The aggregated results are sent to ISR Agents, in the form of Supplier Purchase Matrices (SPMs), and also the corresponding SPMs are sent to the Suppliers, with only the relevant data for the Supplier appearing in the SPMs they receive.

The NHHDA system also supports the comparison of PRS Agent and Data Collector Metering System data. Exceptions are reported to the Suppliers so that any inconsistencies can be operationally resolved.

The NHHDA system user interface enables users to manage instruction files which have been received by the system, maintain Market Domain Data which has been received from the Pool, perform aggregation of EACs and AAs, and generate reports on the data held by the system.

2.1 Users of the System

The NHHDA system will be operated and managed by the Non-Half Hourly Data Aggregator appointed to run it. User roles that have been defined for the application software are as follows:

- Data Aggregation Administrator;
- Market Domain Data Administrator;
- Superior Market Domain Data Administrator;
- Exception Administrator;
- System Operator;
- System Manager;
- Auditor.

2.2 Data Interfaces

Figure 1 places the NHHDA system in the context of the Operational Framework. For further information about the external data interfaces, refer to section 3 of the NHHDA Technical Specification.

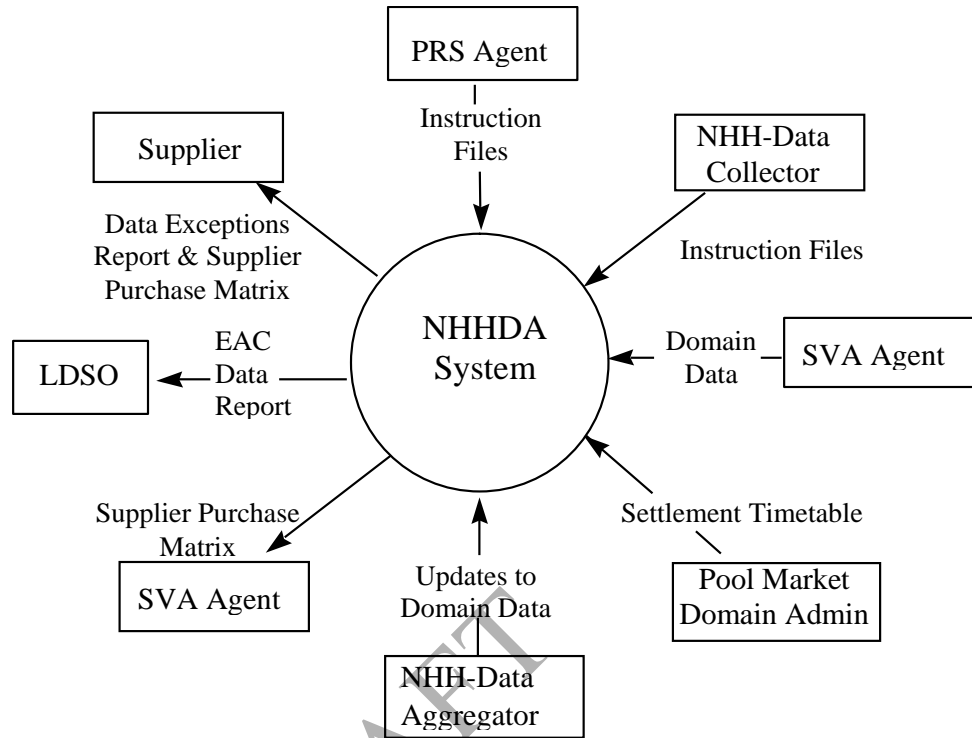

Figure 1: NHHDA External Interfaces

This shows the Data Interfaces to External systems and the data that is passed across the interfaces. The detailed message and data format is given in ELEXON’s Data Interface Specification 005PAT, and the Common Technical Specification 16.4.2.1/010PZT.

3 System Structure

This section describes the NHHDA system, in terms of the main subsystems and file stores. For further information about the directory structure that supports the system, refer to section 0 and for inspection of process state, refer to section 10.1.

3.1 Aggregation Run (NAR) Subsystem

This subsystem aggregates the EACs and AAs for each meter in the system with similar configurations. This aggregation is performed for several Settlement Dates at the same time. The results of the aggregations are written to files, which are forwarded to ISR Agents and Suppliers, via the File Sender (CFS) Subsystem.

The Aggregation Run subsystem also supports the re-sending of aggregation results on request.

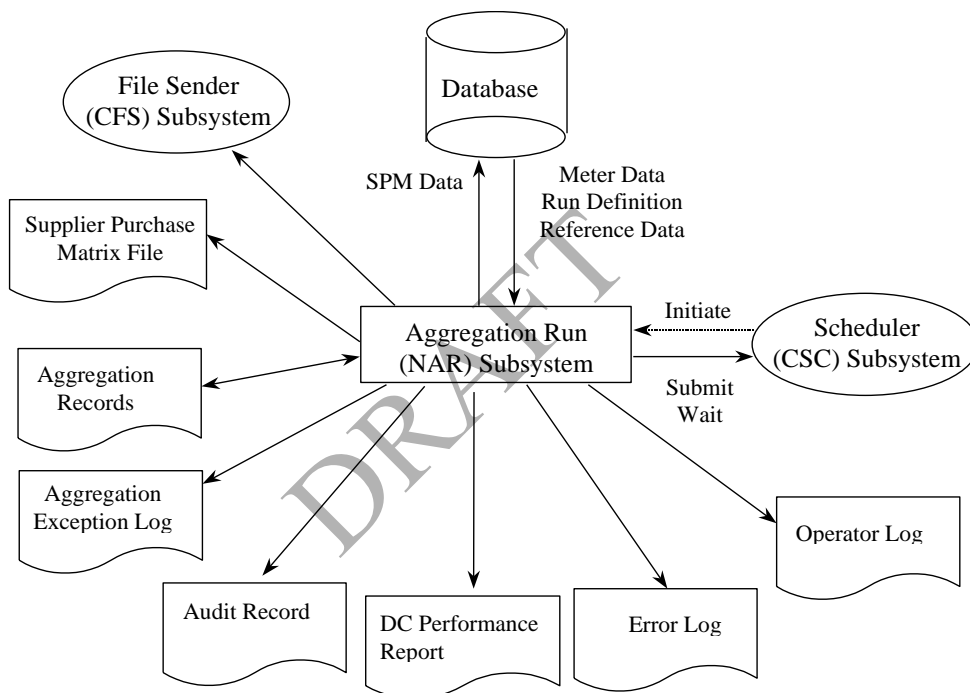

Figure 2: Aggregation Run Subsystem

3.2 Check Data Collector Data (NCD) Subsystem

The NCD subsystem performs checks on Metering System data stored in the NHHDA database. The subsystem checks for consistency between data supplied by Data Collectors and PRS Agents, and checks the EAC/AA data received from potentially multiple Data Collectors. The results of these checks are sent to Suppliers responsible for the meters that have inconsistent data.

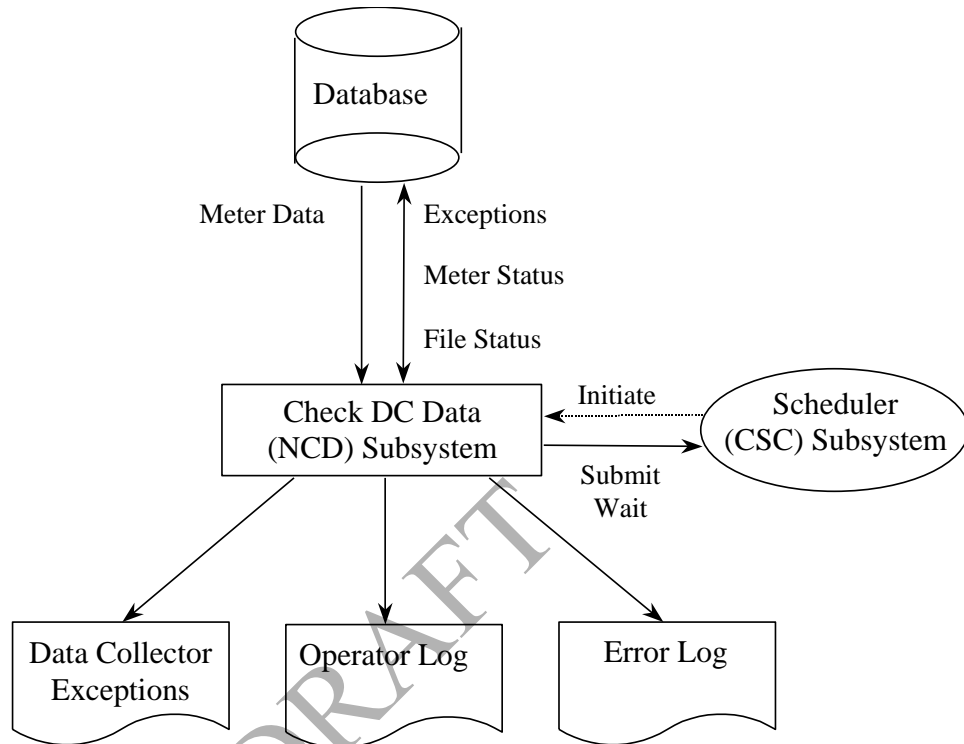

Figure 3: Check Data Collector Data Subsystem

An exception report is generated in the Exception Reports Store if a Standard Settlement Configuration Id exists in the database, and the Standard Settlement Configuration Description is different to that in the database.

3.3 Manage Instructions (NMI) Subsystem

This subsystem validates instructions received from Data Collectors and PRS Agents, and applies valid instructions to the NHHDA database. Functionality is provided enabling users to browse instructions, attempt to reprocess failed instructions, return failed instructions to the originator and control application of refresh instructions from PRS Agents. For further information about these facilities, refer to the NHHDA Operations Guide.

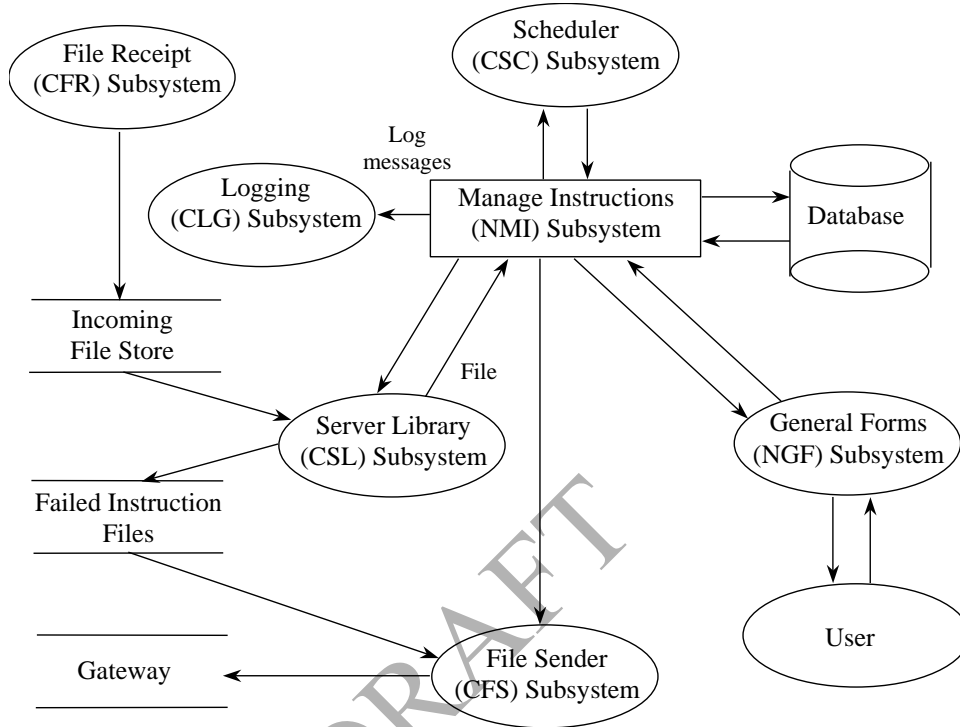

Figure 4: Manage Instructions Subsystem

3.4 Load Data File (NLD) Subsystem

This subsystem loads data files that have been received by the system. The subsystem also enables users to modify and report on the Aggregation Run Schedule.

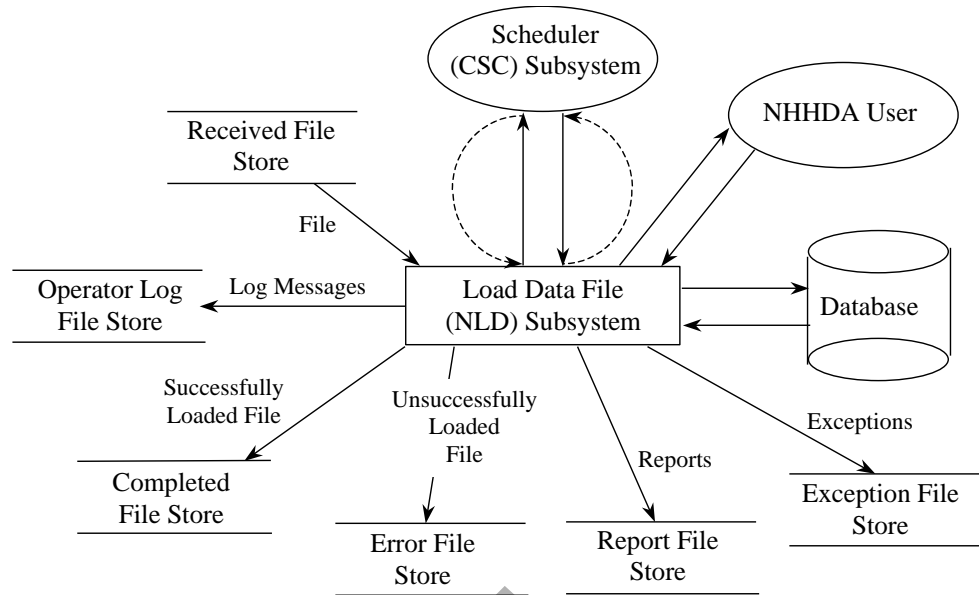

Figure 5: Load Data File Subsystem

3.5 File Receipt Manager (CFR) Subsystem

The File Receipt subsystem is responsible for monitoring the arrival of new files, auditing file receipt and invoking EP98 processing activities where appropriate using the CSC Scheduling subsystem.

A daemon process regularly looks for new external files. For each file found a file reference record is created in the database and the file is moved to the local file store. If automatic processing has been configured, an EP98 processing activity is scheduled using the CSC Scheduler subsystem (see section 6.4 for further information).

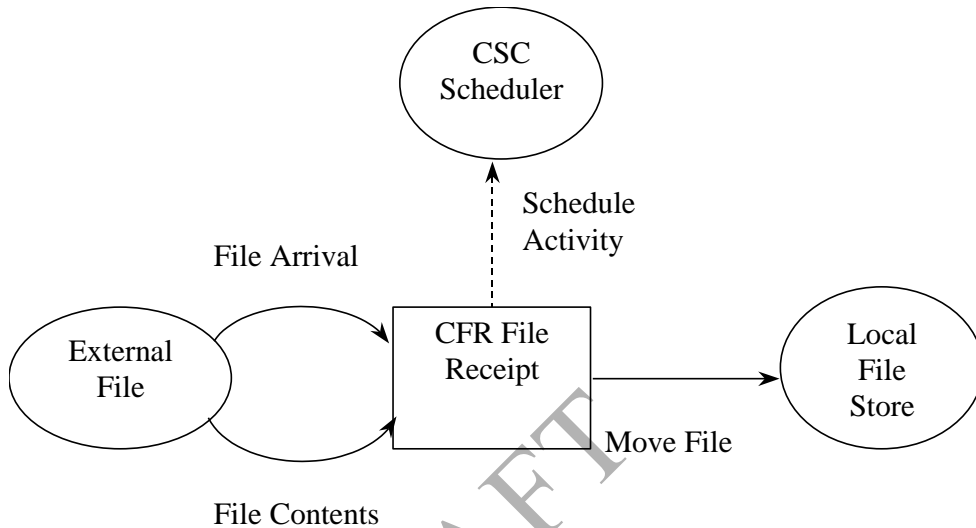

Figure 6: File Receipt Manager Subsystem

3.6 Scheduler (CSC) Subsystem

The Scheduler subsystem provides facilities to schedule and manage the execution of EP98 processes.

A queuing system is used to control server processing activities. For each queue the number of processes that may run concurrently is held in the database.

A number of processing operations are defined. Each operation has an associated executable image and is assigned to run on a particular queue. Each occurrence of a processing operation (activity) is identified by an EP98 activity id which is assigned when the activity is scheduled.

3.7 Logging (CLG) Subsystem

The CLG Logging subsystem provides facilities to write to the following log files:

- operator log - records operational events and data errors (eg: ‘aggregation run started’, ‘out of order instruction file received’, ‘Refresh failed on Metering System 1234’, ‘Refresh Successful’).
- error log - records process and software errors.
- audit log - records details of changes to business data.

Data for the first two logs is written via Oracle pipes, with a daemon process to transfer this data from the pipe to each file.

Data for the audit log is temporarily held in database tables and is periodically written out to a log file.

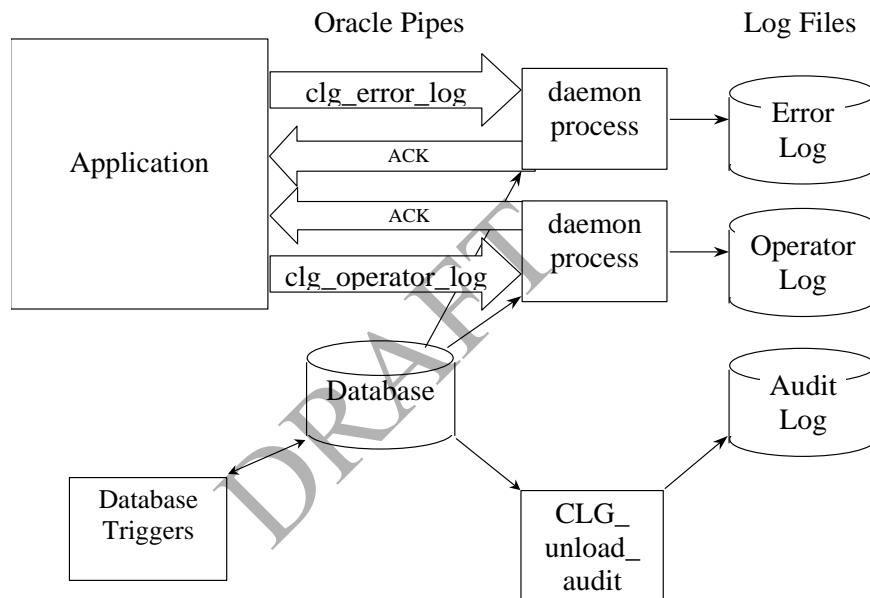

Figure 7: Logging Subsystem

3.8 File Sender (CFS) Subsystem

The File Sender subsystem is responsible for transferring (copying) files from the local file store to the Gateway machine. If a file transfer fails, it is automatically reattempted at a later time.

A database table is used to hold details of files to be sent. A PL/SQL function is provided to insert rows into this table.

Once a file has been transferred the database is updated accordingly, recording the ‘send’ time.

3.9 Report Display (CRP) Subsystem

This subsystem is concerned with the creation of human-readable reports. It operates on the internal report files produced by the system and formats these, based on information held in the database, for human readable display. The resulting output is written to a file which can be displayed at the client or sent for printing. The mechanism for selecting machine-readable reports for display is the Select Reports form. For further information, refer to the NHHDA Operations Guide.

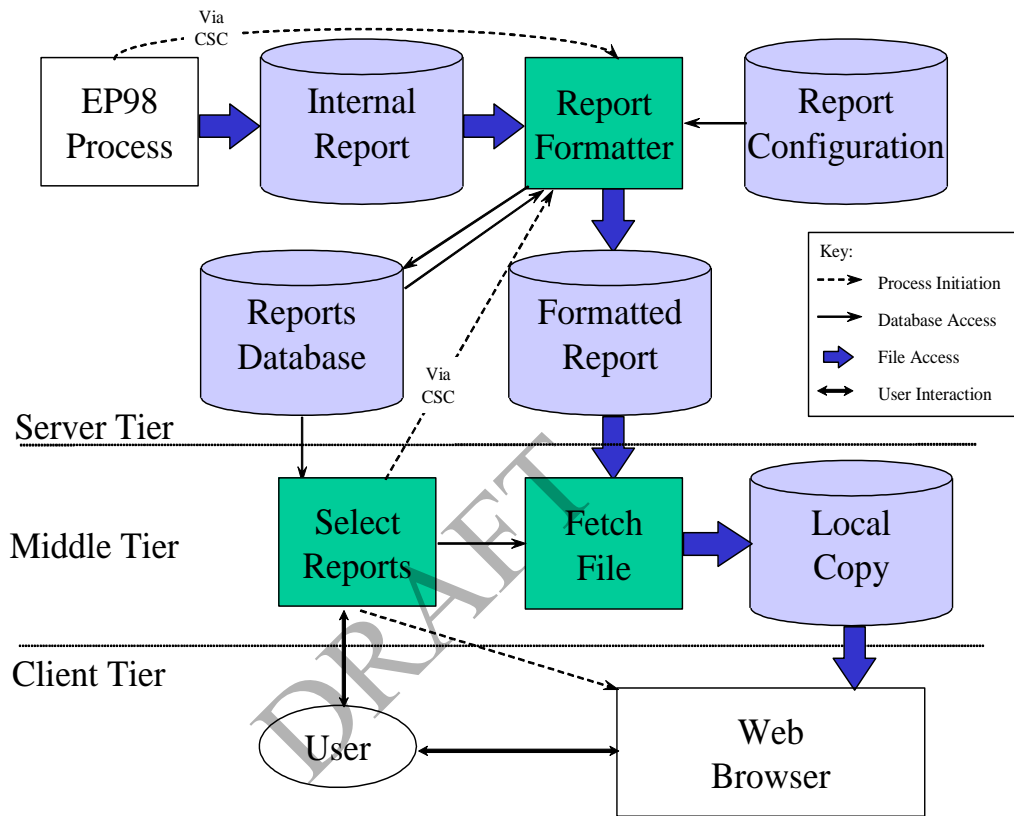

Figure 8: Report Display (CRP) Subsystem

3.10 User Administration (NUA) Subsystem

This subsystem provides two Oracle forms. One provides a facility for a user to change his own password. The other one provides the NHHDA System Manager with a facility to manage users.

The forms work on standard Oracle database tables. No application database tables are involved, but an application view NDB_USER_ROLES is defined. All the work is done directly from the form. No batch process is involved.

For further information about user administration interfaces, refer to the NHHDA Operations Guide.

3.11 EAC Data for Distributor (NDP) Subsystem

The NDP subsystem retrieves EAC data from metering systems for the specified Distributors on the specified date for the report run, and generates

EAC Data to Distributor reports (P0222) to send to the Licensed Distribution System Operator (LDSO).

During the production of the reports the data from the partitioned metering system tables are written to intermediate files, and these files are then aggregated into the report files for each LDSO and an exception log. A report file will only be generated when metering system data for the specified Distributors are found and there is data to be reported; the exception log will always be created and contains details of the number of metering systems found for each Distributor along with the name of the report file, if one was created.

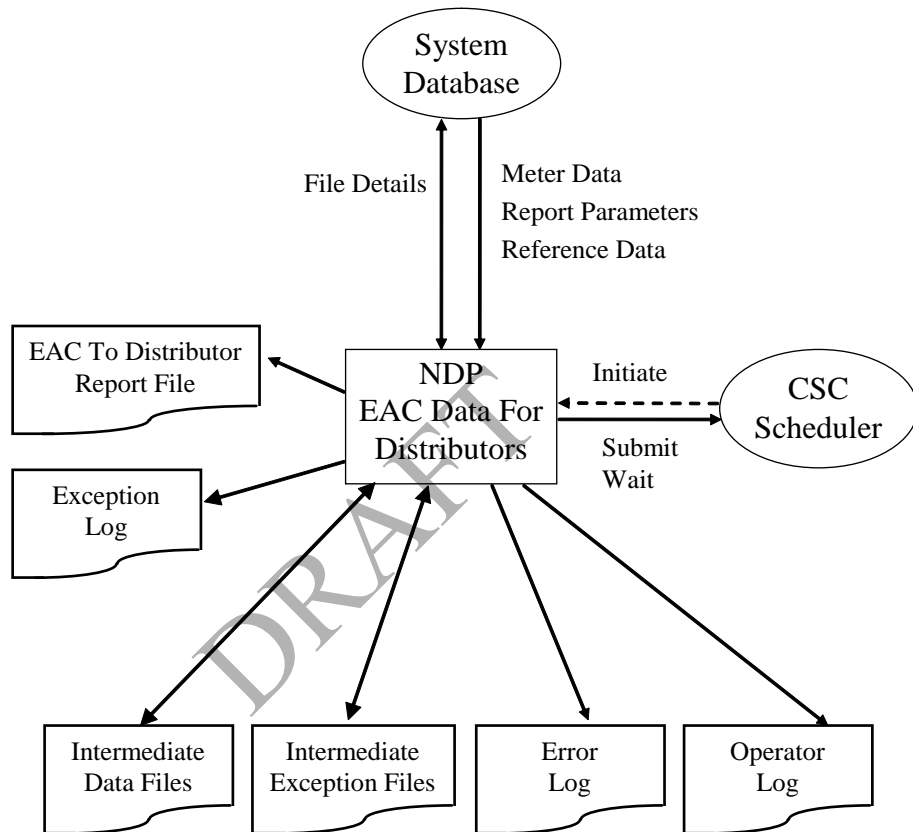

Figure 9: NDP EAC Data for Distributor Subsystem

The EAC Data to Distributor reports will be manually distributed, and the reports are held in sub-directories under the ldsos_out directory; refer to section 6.1. As the reports are being manually distributed the archiving process will not purge the files from the server, and this needs to be done manually. The NHHDA Operations Guide suggests removing the files when they have been manually distributed; refer to the section on manual report distribution.

4 Application Environment

This section provides an overview of the hardware and software environment required for the NHHDA system; provides information to support configuration management; outlines external support for the application software; provides an overview of the tasks that should be included in a schedule for supporting the application environment.

4.1 Hardware

The NHHDA system comprises a POSIX server and a number of PC clients connected over a local area network. Both 3-Tier and 2-Tier physical configurations are supported. An overview of the physical architecture for 3-Tier and 2-Tier is given in Figure 9 and 9a respectively.

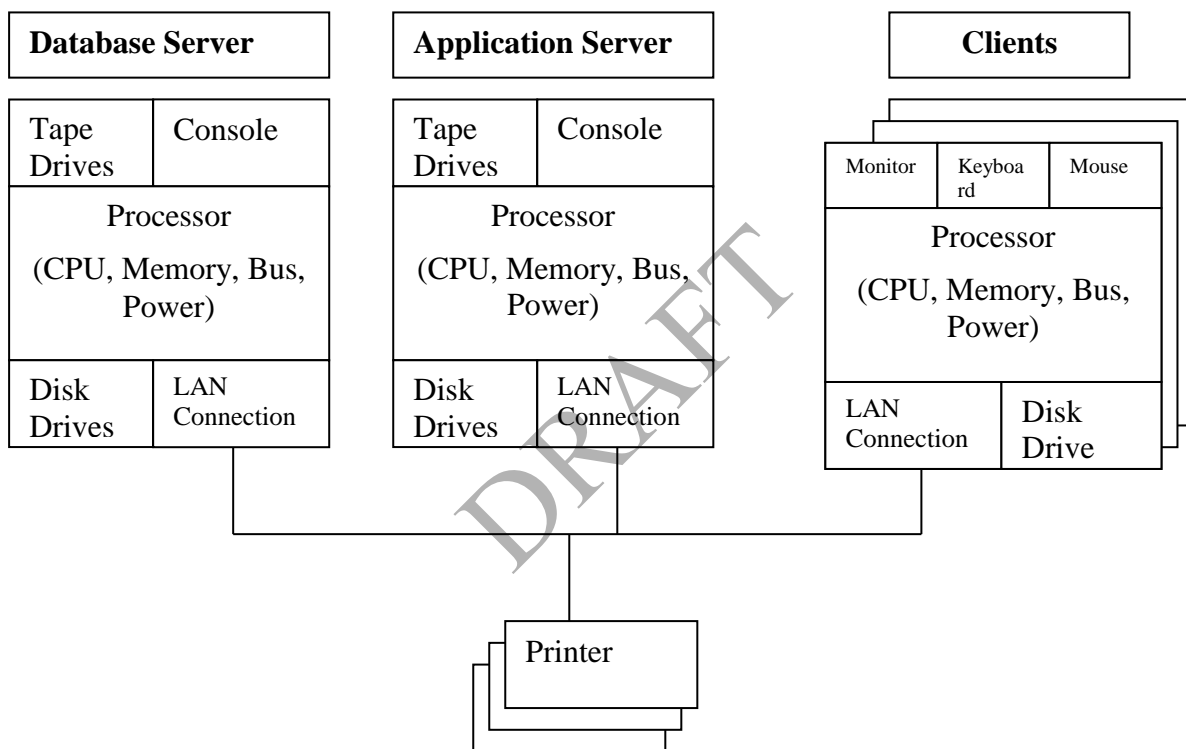

Figure 10: NHHDA 3-Tier Physical Architecture

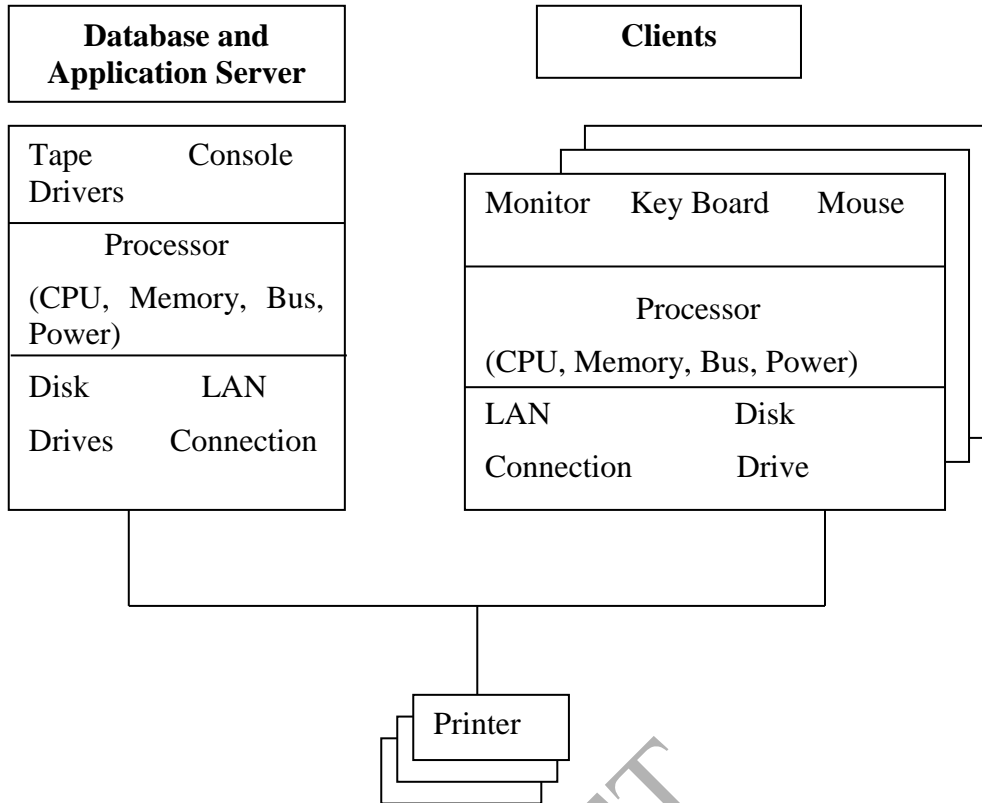

Figure 9a: NHHDA 2-Tier Physical Architecture

The detailed configuration of each component, eg:

- CPU speed and number,
- memory size
- number and capacity of disk drives
- number and capacity of tape drives
- network line speed

is dependent on the volumes to be handled by a particular instance of a system. However, the client monitor is expected to support a display area of at least 1024 by 768 pixels.

All application code for the server is developed assuming a 32-bit architecture.

The “Gateway” is a separate system (outside the scope of the EP98 systems) via which files are sent and received. The interface with the Gateway is assumed to be file transfer across the Local Area Network.

Note that these file transfers are both assumed to be a “push” oriented, ie:

- for receipt the Gateway transfers the files to a directory on the server
- for send the server transfers a copy of the files to a directory on the Gateway.

The following comprises a list of the hardware for the EAC/AA 3-Tier and 2-Tier environment:

Server:

- POSIX-compliant server.

Application Server

- Pentium 3.4Ghz or better Processor;
- 1 GB or better Memory;
- 30 GB Disk Space;

Client

Any that runs an Operating System and Browser supported by Oracle Application Server.

Note: Use any Browser and Operating System in Client system, which is supported by the Oracle Application Server. Refer to Oracle® Application Server Certification Information 11g Release 1 (11.1.1.6.0) B25703-33.

4.2 Software

The NHHDA system server runs an Oracle 11.2.0.3 database with bespoke software written in C and SQL.

For the 3-Tier application, the Application Server runs Oracle Forms 11G version 11.1.1.6.0 on Microsoft Windows 2003 Server as well as Net10 to enable client - server communication.

For the 2-Tier application, the Application server (version 11.1.1.6.0) runs Oracle Forms 11G version 11.1.1.6.0 on a Sun Solaris Server.

The following patches should be applied to the OAS, for both Windows and Solaris: 14373988, 14003476, 14331527 . Details of these patches are given in Appendix G of the Installation Guide [NINGDE].

An overview of the software architecture for 3-Tier and 2-Tier is given in Figure 10 and Figure 10a respectively.

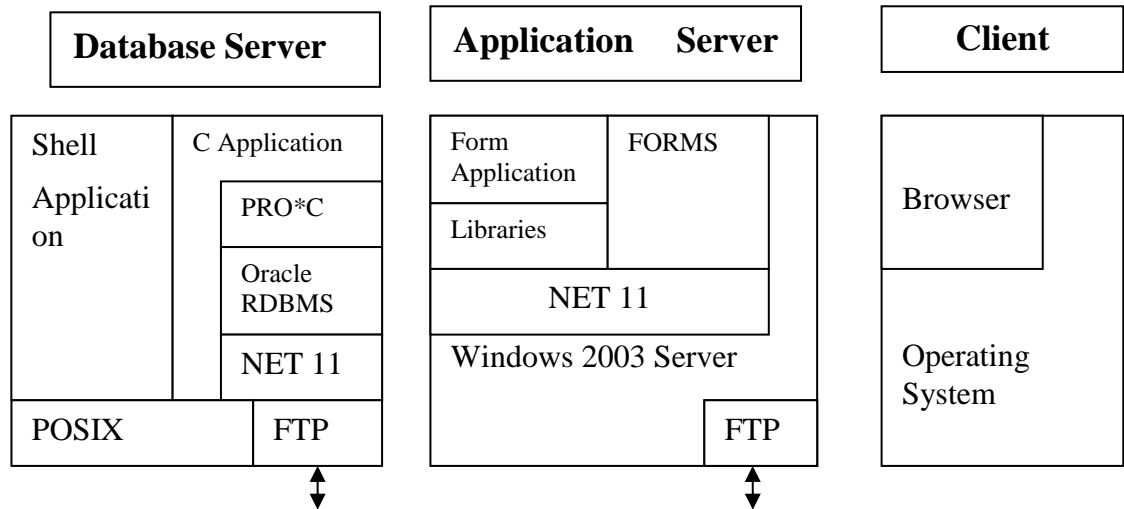

Figure10: NHHDA 3-Tier Software Architecture

The following table shows the software products used to support the NHHDA 3-Tier application software.

Software Component	Host	Version
Operating System	Database Server	Compliant with POSIX standard 1003.1-1990 and POSIX 1003.1b-1993 (C language real time extension). Compliance with POSIX standard 1003.2-1992 for shell scripts. C compiler compliant with ANSI X3.159-1989
Windows 2003 Server	Application Server	Service Pack 1
Oracle Server (includes PL/SQL)	Database Server	11.2.0.3
Net 11	Application Server	11.1.0.7.0
Pro*C runtime	Database Server	11.2.0.3 <i>Runtime deployment is included in original Oracle/Programmer license for development</i>
Oracle Forms runtime	Application Server	11.1.1.6.0 <i>Runtime deployment is included in original Oracle/Developer license for development</i>
File Transfer Software	Server	FTP receive and send



Shell Application	C Application	Forms Application Libraries
-------------------	---------------	-----------------------------



Figure 10a: NHHDA 2-Tier Software Architecture

The following table shows the software products used to support the NHHDA 2-Tier application software.

Software Component	Host	Version
Operating System	Database and Application Server	Compliant with POSIX standard 1003.1-1990 and POSIX 1003.1b-1993 (C language real time extension). Compliance with POSIX standard 1003.2-1992 for shell scripts. (C compiler compliant with ANSI X3.159-1989)
Oracle Server (includes PL/SQL)	Database and Application Server	11.2.0.3
NET 11	Database and Application Server	11.1.0.7.0
Pro*C runtime	Database and Application Server	11.2.0.3 <i>Runtime deployment is included in original Oracle/Developer license for development</i>
Oracle Forms runtime	Database and Application Server	11.1.1.6.0 <i>Runtime deployment is included in original Oracle/Developer license for development</i>

4.3 Configuration Management Procedures

4.3.1 Introduction

During Design, Support and Development, Documentation Products and Application Software Products are kept under configuration control. Under

its Agreement with ELEXON, Cognizant also continues Configuration Control of the Master copies of specified Products ('Maintained Products') until the end of the contract. This controlled framework enables Cognizant:

- a. to issue scheduled releases of maintained documentation and software to ELEXON (ELEXON is then able to distribute copies of documentation to its Agent or Pool members);
- b. to issue corrections to faults to ELEXON;
- c. to issue a release of software under specific direction of ELEXON;
- d. to hand over control of Maintained Products to ELEXON at the end of the support contract.

The following sections summarise the Configuration Control aspects used by Cognizant, which may be of use to the Manager of the Systems at a site in determining how they could be accommodated in the prevailing standards and procedures.

4.3.2 Build and Release numbers

- a. **Documentation:** For document Issue numbering, version numbers which are not x.000 are for drafts. Issued versions have a version number of the form x.000.

Approved versions carry the Copyright of ELEXON.

- b. **Software:** The main allocated Software Releases numbers are as follows:

- 0.2 - Baseline following Initial Factory Acceptance
- 0.3 - Baseline following Final Factory Acceptance
- 0.5 - Baseline issued mid-way through the Pool's System Integration
- 1.0 - Baseline issued at the end of the Pool's System Integration stage
- 2.0 - Intermediate baseline reserved for Trialling
- 3.0 - Baseline reserved for the end of Trialling.
- 4.0 - TA2000 Package One release
- 5.0 - TA2000 Package Two release
- 7.0 – Oracle 8i release
- 7.9.0 - UNIX upgrade to 5.1b; Improvements to usability
- 8.0.0 – Oracle Upgrade to 10g on 2-Tier and 3-Tier Architecture
- 9.0.0 – Port from Tru64 to Sun Solaris Operating System

Intermediate releases for changes or fault corrections use the next decimal place for the Release number (e.g. 0.310, 0.320).

Cognizant stores and manages use of the software by an in-house Configuration Management product (SVN). Use of tool:

- prevents more than one person editing a master file at one time and keeps track of all changes made to that file;

- allows different versions of systems to be built from the same set of source files. (When the code is built the actual lines of code that are compiled is determined by a configuration file specific to a build);
- permits building parts of the system with a single command.

The Software Release Number also includes a specific Cognizant Software Build Number.

c. Defect Report numbers, Remedy, ORs and SFRs: To track exceptions use is made of several numbering systems operating in parallel.

In the case of exceptions reported externally to Cognizant:

- NHHDA raises a defect by raising a call to BSC Service desk through Helpdesk.
- BSC Service desk records the defect in the action request system Remedy generating a Help Desk (HD) number; which is unique to the ISRA, NHHDA and EAC/AA Deliverables.
- Cognizant investigates into the defect and when it's confirmed to be a software fault; a resolution is shared to the NHHDA in the form of amended software. If the defect transforms to be a new requirement on the system after investigation, Cognizant and ELEXON works together with NHHDA towards its implementation.
- Any associated change to the software is labelled and tracked by Cognizant's SVN tool.

The Release Notes associated with a software release give the Help desk number for changes made to the controlled software.

4.3.3 Deliverables maintained under Configuration Control

The Product Deliverables maintained under Configuration Control are distributed on electronic media, namely 700mb CD-r or 4 mm DAT tape for Server related items. The list of the maintained items grouped according to the distribution media and licence type is given in the table below:

NHHDA Maintained Products	Distribution Media (license to use)	Distribution Media (license to use and develop)
Logical Design Products		
Application Style Guide	CD-r	CD-r
Technical System Architecture	CD-r	CD-r
Logical Data Design (Data Structure (*),General notes on the entities, Entity Descriptions, Data Catalogue)	CD-r	CD-r
Conceptual Process Model (Event descriptions)	CD-r	CD-r
Function Definition & User Catalogue (User Catalogue, Functions (*),Common	CD-r	CD-r

Processes (*)		
Physical Design Products		
Common Systems Technical Specification	CD-r	CD-r
Physical Design - Technical Specification	CD-r	CD-r
Development products		
Software Source/Object	Object tape/CD-r	Source/Object tape/ CD-r
Release Notes	CD-r	CD-r
Operational Documentation products		
Installation Guide	CD-r	User Guide CD-r
Operations Guide	CD-r	
System Management Guide	CD-r	
Training products		
Operations Course slides	CD-r	CD-r
System Management Course Slides/ Example scripts	Paper	Paper
Ops/SM.Trainers Kit (notes/exercises/slides)	Trainer's CD-r &	Trainer's CD-r &
Training database build and Example files	DAT tape	DAT tape
Installation Verification Tests	Object tape CD-r	Object tape CD-r

(*) The items denoted with an asterisk contain diagrams which need the SELECT SSADM tool

4.3.4 Compatibility of Deliverable Products

The System Manager should be aware of a number of dependencies between the Deliverable Products. These are summarised below:

- a. Software: Software source and object are issued as a matching set and in general must not be mixed with software from previous releases. In particular Server software must be used with the matching Issue number of Client (PC) software. It may be possible to install revised software to work with a database prepared using an earlier release of software, and in that case this will be made clear in the release notes. There may also be occasions where it is possible for an emergency defect repair (patch) to be made to a particular part of the installed software, and in that case it should be done according to the instructions delivered with the patch.
- b. Third party software products: Application Software assumes that the hardware and software environment on which the software is to be installed include the third party products at the version levels given in sections 4.1 and 4.2 above.
- c. HELP file and Operations Guide: The Microsoft WORD file for the Operations Guide is used to create the HELP file distributed on the Application software CD. In general, if a screen or report format is changed then the relevant page(s) of the Operations Guide will change and the HELP file will also reflect that change; the System Manager should ensure that any revised page or pages supplied are distributed at the system site when the revised software is installed.

- d. Other Product Deliverables: Where a change or defect correction applies to one of the other Maintained Deliverables, Cognizant will correct the master copy of that Deliverable. Distribution of copies of the revised Product Deliverable will depend on the support arrangements in place.

4.4 External Support

- a. Problem with Distribution Kit: If the site has a problem with the distribution kit - faulty media, for example - then it should contact Helpdesk.
- b. Problem with the Software or Documentation: If any problem is encountered with the software itself then the user should contact Helpdesk.

DRAFT

4.5 Schedule of Activities

The Manager of the Systems at a site should define a schedule of daily and weekly activities to maintain the system and keep it operable. This will include strategies for backup and archive, and a statement of the division of responsibilities with the database administrator. Clearly, a large part of these definitions will be site dependent, depending on such things as the actual hardware and software environment used and the existing site procedures. However, there are certain activities which are specific to the Application software and generic to UNIX; the table summarises some of these, and gives a reference to the section in this Guide on the topic:

Activity (includes checking that automatic processes have completed)	Type	Ref.
Backups of NHHDA database and filestore, and keeping a log of these; resetting locks	Daily, Weekly, Monthly	13, 9.3
Archiving of data	Daily, Weekly	12, 7
Monitoring Logs for correct operation, and clearing out old copies	Daily, Weekly	11
Maintenance of the values of System Parameters	Ad-hoc	7
Setting up/changing User Accounts	Daily, Weekly	8
Configuring the location of Data Aggregation intermediate files	Ad-hoc	6
System Management examples: <ul style="list-style-type: none"> - Starting up and shutting down the System - Installing new PCs on local network, including Oracle client software and Application software - Keep records of system configuration and changes to it - changing device ownership - changing file ownership - checking that available disk space is adequate - installing new releases of software 	Ad-hoc	4, 10 Installation Guide

5 Database Organisation

This section provides information on the NHHDA database.

Refer to the NHHDA Physical Design for the logical data structure and full data dictionary. The data dictionary can be accessed on-line.

5.1 Database Tables

The NHHDA database tables and views on tables are listed below, with a brief description of the data they hold. Those marked with an asterisk (*) are views.

Table or View Name	Description
Scheduled Jobs	
cdb_activity	Contains a row for every process that has been scheduled to run on the system (waiting to run, running, completed).
cdb_activity_parameter	Contains a row for each parameter for every process that has been scheduled to run on the system (waiting to run, running, completed).
cdb_activity_type	Each row details a processing activity that can be initiated via the Scheduler.
cdb_default_parameter	Contains a row for each parameter used by default when starting the processing activities given in cdb_activity_type
cdb_queue	Each row details a queue.
Audit	
cdb_audit_n	Set of 7 tables. Each row records which database tables have been changed and the type of change, eg. insert. Refer to section 9 for further information.
cdb_audit_fields_n	Set of 7 tables, each of which corresponds to a cdb_audit_n table. Each row records field values after an auditable change. Refer to section 9 for further information.
File Information	
cdb_file_reference	Each row details a file received and generated by the NHHDA application software, except temporary files.
cdb_data_file	Each row contains information about a data file, in addition to cdb_file_reference
cdb_instruction_file	Each row contains information about an instruction file, in addition to cdb_file_reference
cdb_default_directory	Records the directory into which a file of a particular type should be placed when its status changes. Refer to Section 6.3 for further information.
cdb_file_export	Contains a row for each file waiting to be sent to the Gateway machine.
cdb_export_configuration	Contains a row for each file type that is exported.
cdb_file_directory	This table holds the Operating System path of the directories that make up the local file store, and indicates the directories to be monitored for the

Table or View Name	Description
	arrival of new files. Refer to section 6.1 for further information.
cdb_file_processing	Each row defines a type of file that is handled by the File Receipt process, the corresponding activity invoked to process the file and a flag indicating whether the file should be processed automatically upon receipt.
cdb_resend_access	Defines which files each user role can resend via the Resend Button.
cdb_return_parameter	Maintains a count of resent instructions
Parameters	
cdb_system_parameter	Contains a row for every system parameter. Refer to section 7 for further information.
cdb_error_messages	Contains a row for each error message used by the NHHDA forms application.
cdb_ref_domains	Contains an entry for each domain (data field for which there are a limited set of values).
cdb_ref_values	Holds valid values for each domain held in cdb_ref_domains.
Formatted Reports	
cdb_field_headers	Contains details of field headers to be used in formatted reports.
cdb_field_info	Holds details of the fields in the reports.
cdb_record_info	Holds information on the relationship between records in a report
cdb_report_access	Defines which reports each user role can access via the Select Reports form.
cdb_report_file	Each row contains information about report files that can be viewed via the Select Reports form
cdb_report_type	Each row contains a report that can be accessed by users from the PC via the Select Report form.
NHHDA Business Specific	
ndb_agg_gsp_temp	Temporary table used during Aggregation to hold Metering System totals for a given GSP Group, Partition Id and Run Number.
ndb_av_frac_y_cons	Each row specifies the Average Fraction of Yearly Consumption that is attributed to a particular combination of Measurement Requirement, Profile Class and GSP Group.
ndb_check_dc_data_runs	Each row a request for a Check Data Collector Data report.
ndb_d0095_exceptions_summ *	A view holding exception counts used by the Monthly D0095 Report.
ndb_data_agg_apps *	Each row is a record of the appointment of the NHH Data Aggregator to a Registration.
ndb_data_agg_runs	Each row is the record of an aggregation run or request.
ndb_dc_apps *	Each row contains a record of the appointment of a Data Collector to a Registration.

Table or View Name	Description
ndb_exception_data	Each row contains the detail for a D0095 exceptions summary report. The reports are generated on an ad-hoc basis every month.
ndb_gsp_group_run	Each row defines a GSP Group which is included in a Data Aggregation Run.
ndb_gsp_groups	Each row defines a group of one or more Grid Supply Points which together serve all or part of a Distribution System.
ndb_gsp_groups_dis	Each row defines which Distributor owns and operates the Distribution System supplied via a GSP Group and the corresponding PRS Agent.
ndb_gspg_pc_av_eac	Each row defines the average Estimated Annual Consumption for a GSP Group / Profile Class combination.
ndb_instruction_status_reason	Contains reasons for an Instruction being in its current state.
ndb_instructions	Each row contains information on an Instruction that is contained in an Instruction file received by the NHHDA system.
ndb_isr_agent_apps	Each row details the appointment of an ISR Agent to a GSP Group.
ndb_llf_classes	Each row defines a Line Loss Factor Class and the identity of the Distributor who defined the Class.
ndb_m_participants	Each row defines an organisation that participates in the Market.
ndb_measure_reqs	Each row defines a valid combination of Standard Settlement Configuration and Time Pattern Regime
ndb_metering_sys *	Each row defines a Metering System
ndb_ms_dc_dets *	Each row contains information about the Metering System supplied by a Data Collector, and the settlement date from which the information is effective.
ndb_ms_exceptions *	Each row contains details of an exception that has been recorded against a Metering System.
ndb_ms_prs_dets *	Each row contains information about the Metering System supplied by the PRS Agent, and the settlement date from which the information is effective.
ndb_nar_file_location	Defines where aggregation temporary files are written. 1 row per partition. Allows files for each partition to be stored on a different physical disk
ndb_nar_files	Internal table used to record all temporary files created by aggregation.
ndb_nmi_ms_id_list	Temporary table populated with all the Metering Systems for the distribution business which is the subject of the PRS Refresh currently being applied.
ndb_profile_classes	Each row defines a Profile Class.
ndb_refresh_instr_failure	Contains one or more Metering System level validation failure for PRS Refresh Instructions.
ndb_refr_instr_failure_reason	Contains one or more Metering System level

Table or View Name	Description
	validation failure reasons for the PRS Refresh Instruction failures recorded in table <code>ndb_refresh_instr_failure</code> .
<code>ndb_register_cons *</code>	Each row is a specific Data Collector's view of the Annualised Advance or Estimated Annual Consumption of one of the Settlement Registers of a Metering System.
<code>ndb_registrations *</code>	Each row is a record of the Registration of a Supplier to a Metering System.
<code>ndb_report_agg_exceptions</code>	Temporary table used by Aggregation exceptions report process.
<code>ndb_report_parameters</code>	Temporary table used by report processes.
<code>ndb_settlements</code>	Each row defines a calculation of the funds to be cleared between Suppliers and Generators in respect of electricity traded through the Pool on a Settlement Day. This includes Interim Information, Initial Settlement and Reconciliation.
<code>ndb_spmatrix</code>	Each row contains the Annualised Advance and Estimated Annual Consumption information for one of the cells in the five-dimensional matrix. The dimensions of the matrix are: Supplier, Line Loss Factor Class, Measurement Requirement, Profile Class and GSP Group / Aggregation Run.
<code>ndb_std_sett_cfgs</code>	Each row defines a Standard Configuration which Metering Systems may assume.
<code>ndb_t_p_regimes</code>	Each row contains a valid Time Pattern Regime.
<code>ndb_temp_mdd_load_audit</code>	A temporary table used to store changes made to specific database tables updated via the MDD_LOAD process, used to produce an audit report.
<code>ndb_threshold_pars</code>	Each row contains a Threshold Parameter and the Settlement Date within which it is valid.
<code>ndb_vsscpcs</code>	Each row defines a valid combination of Standard Settlement Configuration and Profile Class.

5.2 Partitions

Due to the need for fast and parallel access to metering information by the Data Aggregation process, all tables that contain the `METERING_SYSTEM_ID` column have been set up as partition views.

These are:

- `NDB_METERING_SYS`
- `NDB_REGISTRATIONS`
- `NDB_DATA_AGG_APPS`
- `NDB_DC_APPS`
- `NDB_REGISTER_CONS`
- `NDB_MS_DC_DETS`

- NDB_MS_PRS_DETS
- NDB_MS_EXCEPTIONS

This means that instead of one physical table for each of these tables there are now several tables and a unifying view for each. This allows the data to be physically spread across many disks in a highly controlled manner.

The number of partitions for a particular configuration is determined during installation, being based on the number of METER_PARTITION_n tablespaces defined (see section 5.3 for an overview of the tablespaces).

Note that the number of METER_PARTITION_n tablespaces and hence the number of partitions can be specified only prior to installation of the NHHDA database, and cannot be configured thereafter. Refer to Appendix A of the NHHDA Installation Guide for further information.

5.3 Tablespaces

The NHHDA database contains the following application specific tablespaces:

- USERS - contains all NHHDA standing data tables and the following table containing temporary data :
 - ndb_temp_mdd_load_audit
- USERS_INDEXES - contains indexes for tables contained in USERS tablespace.
- INSTRUCTIONS - contains the tables ndb_instructions and ndb_instruction_status_reason
- INSTRUCTIONS_INDEX - contains indexes for tables contained in INSTRUCTIONS tablespace
- METER_PARTITION_n - contains tables listed in section 5.2 above - the number of tablespaces is dependent on the number of processors, metering systems and memory in the system configuration. Refer to Appendices A, C and D of the NHHDA Installation Guide for examples.
- METER_PARTITION_INDEX_n - contains indexes for the tables listed in section 5.2 above - the number of indexes is dependent on the number of partitions used.
- TEMP_OBJECTS - contains the following tables, (those marked with * are temporary tables):
 - ndb_report_parameters *
 - ndb_nar_file_location
 - ndb_nmi_ms_id_list *
 - ndb_check_dc_data_runs *
 - ndb_nar_files *
 - ndb_spmatrix
- TEMP_OBJECTS_INDEX - index for the TEMP_OBJECTS tablespace

- AUDIT1...7 - contains the cdb_audit_n and cdb_audit_fields_n tables.

For information about the tables and indexes defined within these tablespaces, refer to Appendix D of the NHHDA Physical Design.

5.4 Timestamps

Each record in cdb_file_reference, (each row details a file received and generated by the NHHDA application software) uses one or more of the following timestamps:

- creation_time - the time at which the file was created by the NHHDA application software;
- received_time - the time at which the file was received by the NHHDA application software;
- process_send_time - the time at which the file was transmitted to the Gateway by the NHHDA application software.

Each of these timestamps is held as a GMT value, reflecting the time format in the headers of the corresponding files.

Note that all other timestamps used in the NHHDA application software are held in local time. Refer to the NHHDA Operations Guide for further information.

5.5 Domains

Lists of valid values of various columns are all combined into one table, to avoid the proliferation of small tables. Each set of values is called a domain. Two tables are defined to hold this information:

- cdb_ref_domains holds a record for each domain;
- cdb_ref_values holds a record for each value.

The domains held in the cdb_ref_domains table are as follows:

- **ARCD** Archive Directory Path;
- **ENST** Energisation Status;
- **EXDC** Exception Type (Check Data Collector Data);
- **EXTP** Exception Type (Aggregation);
- **FSTS** File Status;
- **FTIN** Incoming Files;
- **FTOT** Outgoing Files;
- **INSR** Instruction Status Reason;
- **INST** Instruction Status;
- **INTP** Instruction Type;
- **INRP** Instruction Reprocess State;
- **INRS** Instruction Status Resolution State;
- **MAPR** Market Role;
- **MECL** Measurement Class;
- **NDPD** **Directory Path For EAC To Distributor Report;**
- **RNST** Run Status;
- **SECO** Settlement Code.

For these domains, the following domain values are stored in the cdb_ref_values table:

Archive Directory Path (ARCD)

value_from	Description
runtime/files/archive	Archive Directory Path

Energisation Status (ENST) Domain

value_from	Description
E	Energised
D	De-energised

Exception Type (EXDC) Domain

value_from	Description
E01	No EAC or AA for appointed DC
E02	Missing subsequent consumption data
E03	AA with no DAA appointment
E04	EAC with no DAA appointment
E05	Non-zero AA when de-energised
E06	Missing preceding consumption data
E07	Overlapping MAPs
E08	Supplier incorrect
E09	Measurement Class incorrect
E10	GSP Group incorrect
E11	Profile Class incorrect
E12	Energisation Status incorrect
E13	Standard Settlement Configuration incorrect
E14	No Registration

Exception Type (EXTP) Domain

value_from	Description
A01	No EAC or AA for Metering System
A02	No PRS Data Provided
A03	Non-zero AA when de-energised
A04	Multiple Meter Advance Periods
A05	Supplier incorrect
A06	Measurement Class incorrect
A07	GSP Group incorrect
A08	Profile Class incorrect
A09	Energisation Status incorrect
A10	Standard Settlement Configuration incorrect

value_from	Description
A11	AA for Unmetered Metering System
A12	Metering System Excluded
A13	Missing AFYC
A14	Missing Default EAC

File Status (FSTS) Domain

value_from	Description
0	Default
1	New
2	Deleted
3	Received
4	Completed
5	Sent
101	Running
102	Rejected
103	Archived
104	Loaded
105	Processed
106	Corrupt
107	Skipped

For information about each of the above File Statuses, refer to the Browse File Loading Status, Browse File Extraction and Transmission Statuses and Browse Aggregation Files sections in the NHHDA Operations Guide.

Incoming Files (FTIN) Domain

value_from	Description
D0019001	DC Instruction File
D0209001	PRS Instruction File
D0269002	Market Domain Data Complete Set
D0286001	Data Aggregation and Settlement Timetable File
L0000001	Corrupt / Unknown File

Outgoing Files (FTOT) Domain

value_from	Description
D0023001	Failed Instructions File
L0009001	Load Timetable Exceptions
L0040001	Load MDD Exceptions Log
D0041001	Supplier Purchase Matrix Data File
D0095001	Data Collector Exceptions
L0037001	Aggregation Exception Log

L0038001	Aggregation Run Log
L0032001	Supplier Purchase Matrix (Report)
L0033001	Check Data Collector Exception Log (Report)
L0034001	Aggregation Exception Log (Report)
L0011001	GSP Groups (Report)
L0012001	Standard Settlement Configurations (Report)
L0013001	Average Fraction of Yearly Consumption (Report)
L0014001	Distributors and Associated Items (Report)
L0015001	Metering Systems and Associated Items (Report)
L0016001	Instructions (Report)
L0017001	Data Aggregation Run Schedule (Report)
L0044001	Metering System History, EACs and AAs (Report)
L0020001	Profile Classes (Report)
L0042001	Refresh Instruction Failures (Report)
L0043001	DC Performance (Report)
L0001001	Audit Log
L0003001	Formatted Report
L0004001	Operator Log
L0005001	Error Log
P0147001	Monthly D0095 report
L0051001	EAC To Distrib Intermediate Data
L0052001	EAC To Distrib Intermediate Exceptions
L0053001	EAC To Distributor Exceptions
P0222001	EAC To Distributor Data (Report)

Instruction Status Reason (INSR) Domain

Value_from	Description
0A	Refresh accepted with validation errors
0B	Instruction type is not valid for source
0D	Manual Discard
0F	Automatic discard due to failure
0I	Invalid Instruction
0S	Instruction has been superseded
0T	Refresh totals
0W	Wrong Distributor
2C	>1 DC Appt on or before Sig Date
2E	>1 ES on or before Sig Date
2G	>1 GSP Group on or before Sig Date
2L	>1 LLFC on or before Sig Date
2M	>1 MC on or before Sig Date
2P	>1 PC/SSC on or before Sig Date
2R	>1 Registration on or before Sig Date

Value_from	Description
2Y	>1 EAC on or before Sig Date
99	99 or more failure reasons
AA	DA Appt end after Registration end
AE	ES Start after Registration End
AM	MC Start after Registration End
AP	PC/SSC Start after Registration End
CA	DA Appt ends before Sig Date
CE	ES change during MAP
CM	MC change during MAP
CR	Registration change during MAP
CS	SSC change during MAP
DC	Duplicate DC Appt Start
DE	Duplicate ES Start
DG	Duplicate GSP Group Start
DL	Duplicate Line Loss Factor Start
DM	Duplicate MC Start
DP	Duplicate PC/SSC Start
DR	Duplicate Registration Start
DY	Duplicate EAC Start
EA	DA Appt End before Sig Date
EB	DA Appt Start before Registration Start
EC	DC Appt Start before Registration Start
EE	ES Start before Registration Start
EM	MC Start before Registration Start
EP	PC/SSC Start before Registration Start
EX	AA End before Sig Date
FE	No ES for 1 st consumption
FG	No GSP Group for 1 st consumption
FM	No MC for 1 st consumption
FP	No PC/SSC for 1 st consumption
FR	No Registration for 1 st consumption
IA	Invalid PC, SSC & GSP Group for AFYC
IC	DC ID not found on dB
IE	Invalid ES
IG	GSP Group ID not found on dB
IL	Distributor/LLFC not found on dB
IM	Invalid MC
IP	PC ID not found on dB
IR	Supplier ID not found on dB
IS	SSC ID not found on dB
IV	EAC/AA value outside permitted range
MA	DAA before Sig Date not latest on dB

Value_from	Description
MC	DC Appt before Sig Date not latest on dB
ME	ES before Sig Date not latest on dB
MG	GSP Group before Sig Date not latest on dB
ML	LLFC before Sig Date not latest on dB
MM	MC before Sig Date not latest on dB
MP	PC/SSC before Sig Date not latest on dB
MR	Registration before Sig Date latest not on dB
MX	AA before Sig Date not latest on dB
MY	EAC before Sig Date not latest on dB
NE	ES not overlapping DA Appt
NG	GSP Group not overlapping a DA Appt
NL	Line Loss Factor not overlapping DA Appt
NM	MC not overlapping a DA Appt
NP	PC/SSC not overlapping DA Appt
NR	No DAA for Registration in instruction
OA	Overlapping DA Appts
OX	Overlapping MAPs
RA	DA Appt references unknown Registration
RC	DC Appt references unknown Registration
RE	ES references unknown Registration
RM	MC references unknown Registration
RP	PC/SSC references unknown Registration
SC	No DC Appt for 1 st DAA in Registration
SE	No ES for 1 st DA Appt in Registration
SG	No GSP Group before 1 st DA Appt
SL	No LLFC before 1 st DA Appt
SM	No MC for 1 st DA Appt in Registration
SP	No PC/SSC for 1 st DAA in Registration
TV	AA with duplicate Time Pattern Regime
TW	EAC with duplicate Time Pattern Regime
TX	AA missing for Measurement Req(s)
TY	EAC missing for Measurement Req(s)
UX	AA where Time Pattern Regime not in SSC
UY	EAC where Time Pattern Regime not in SSC
VG	GSP not appointed to Dist Business
VP	PC/SSC combination not on dB
VZ	PRS Agent not appointed in this GSP Group
XA	DA Appt Start after End
XX	AA Start after End
ZA	DAA on dB missing from instruction
ZC	DC Appt missing from instruction
ZE	ES missing from instruction

Value_from	Description
ZG	GSP Group missing from instruction
ZL	LLFC missing from instruction
ZM	MC missing from instruction
ZP	PC/SSC missing from instruction
ZR	Registration missing from instruction
ZX	MAP on dB missing from instruction

For an explanation of these errors, see Appendix C of the Operations Guide.

Instruction Status (INST) Domain

value_from	Description
U	Unprocessed
F	Failed
S	Superseded
A	Applied
D	Discarded
V	Invalid

Instruction Type (INTP) Domain

value_from	Description
NH01	Data Aggregator Appointment Details
NH02	Data Collector Appointment Details
NH03	Profile Class/SSC in Registration Details
NH04	Measurement Class in Registration Details
NH05	Energisation Status in Registration Details
NH06	GSP Group Details
NH07	Line Loss Factor Class Details
NH08	PRS Refresh
NH09	EAC/AA & MS Details

Instruction Reprocess (INRP) Domain

value_from	Description
R	Reprocess
X	Cannot be reprocessed

Instruction Status Resolution (INRS) Domain

value_from	Description
Y	Resolvable
R	Resolved
N	Not resolvable

Market Roles (MAPR) Domain

Only those roles referenced by NHHDA are included in this list.

Value_from	Description
B	Non-HH Data Aggregator
D	Non-HH Data Collector
G	ISR Agent
P	PRS Agent
R	Distributor
U	Market Domain Data Agent
X	Supplier
Z	Pool (Administrator)

Measurement Class (MECL) Domain

value_from	Description
A	Non half hourly metered
B	Non half hourly unmetered
C	Half hourly metered
D	Half hourly unmetered

Run Status (RNST) Domain

value_from	Description
P	Provisional
A	Approved
R	Released
U	Running
F	Failed
S	Successful
D	Provisional Default

Settlement Code (SECO) Domain

value_from	Description
II	Interim Information
SF	Initial Settlement
R1	First Reconciliation
R2	Second Reconciliation
R3	Third Reconciliation
RF	Final Reconciliation
DR	Dispute
DF	Final Dispute

Directory Path For EAC To Distributor Report (NDPD) Domain

value_from	Description
runtime/files	Directory Path For EAC To Distributor Report

For each domain in `cdb_ref_values`, the descriptions can be modified if required, using interactive SQL. However, for the majority of the domains the `value_from` field values *must not be modified*, as these are used by the application software.

The domain NDPD is not a true domain as it is used to hold the path where the EAC Data to Distributor reports will be moved when the report files have been completed. The value from field can be updated with a new path, and the NDP_PC process will create the `ldso_out` directory in the new location when it next runs; note the NDP_PC process actually compares the path specified by the NDPD domain with the current path for completed EAC Data to Distributor report, and when they differ it will create the `ldso_out` directory.

5.6 Database Sizing

Please refer to the Installation Guide (ningde) Appendix A – NHHDA Oracle Tablespaces.

5.7 Physical Organisation (Tablespaces/Files)

The physical configuration of each installation of the NHHDA system is dependent on the installation environment, in particular the number and capacity of disks and number of processors.

The following information is given only as an example of a configuration of the NHHDA system. It does *not* constitute a recommendation for disk configuration of the NHHDA system.

Refer to Appendix D of the NHHDA Installation Guide for an example configuration.

The example configuration comprises a number of core disks, as follows:

1. System files (ie. Operating system), Paging space;
2. NHHDA executables, Oracle Executables, Paging space, Log files (Operator Logs, Error Logs, Process Output Logs);
3. Oracle Redo Logs;
4. Database table space (audit tables), SPM output files, CFR input directory, Exceptions Output files;
5. Database table space (SPM table data), Input Instruction Files;
6. Database table space (other tables' data);
7. Database table space (SPM index and other indices).

Additionally, the example configuration contains the following sets of disks, which are dependent on the number of processors:

1. Database table space (Partition data), Aggregation intermediate files;
2. Database table space (Partition index and Exception index), Rollback segments;

3. Database table (Exception Data), Sort space.

5.8 Oracle Parameters

The parameters listed below are identified as necessary for NHHDA to work correctly. Other parameters can be set to tune the Oracle instance or run it in a certain way. For further information about Oracle Parameters, refer to the NHHDA Installation Guide.

Parameter	Value	Comment
compatible	10.2.0	minimum Oracle release number NHHDA requires
log_archive_dest	<directory>	must be set to a directory spec – actual value unimportant
log_archive_start	True	enables archive logging
log_checkpoint_interval	larger than redo log size	ensures that checkpoints do not happen between log switches
log_checkpoint_timeout	0	ensures that checkpoints do not happen between log switches
processes	200 or above	number of concurrent processes that can run against database
row_locking	Always	enables row-level locking
utl_file_dir	*	specifies which directories Oracle writes flat files to (e.g. for auditing). For details of alternative settings to '*' please refer to the NHHDA Installations Guide.

5.9 Oracle Object Storage Parameters

Some NHHDA database tables and indexes may need to be allocated free space, to allow for updates to blocks in the tables. The actual requirements for each table or index will depend on how the system is operated by the User organisation and therefore, recommendations cannot be given. However, some *guidelines* are given in the table below.

The amount of free space, denoted in the Percentage Free column, shows the percentage of free space for each block in a table that is allocated for updates. Note that the database tables not included in the table below cannot be updated, or updates to a record would not change the size of the record. Additionally, the Percentage Used column indicates the utilisation percentage below which the free space in a block in a table can be used for new inserts.

Table, View or Index Name	Percentage Free (%)	Percentage Used (%)
cdb_activity	6-7	80
cdb_activity_parameter	N/A	80
cdb_file_reference	2	80
cdb_file_directory	5	N/A
cdb_system_parameter	5-10	N/A
cdb_report_file	N/A	80

Table, View or Index Name	Percentage Free (%)	Percentage Used (%)
ndb_av_frac_y_cons	5	N/A
ndb_gsp_groups	20	N/A
ndb_gspg_pc_av_eac	5	N/A
ndb_instructions	10	N/A
ndb_llf_classes	10	N/A
ndb_m_participants	10	N/A
ndb_metering_sys	10	N/A
ndb_profile_classes	10	N/A
ndb_std_sett_cfgs	N/A	N/A
fpro_fk1_i (index to cdb_file_reference)	10	N/A
fref_type_status_i (index to cdb_file_reference)	10	N/A

5.10 Oracle Performance Tuning : Optimiser Statistics

In continuation of the approach from Oracle 10g, in 11g also, the Rule Based Optimiser is not supported; Oracle supports the Cost Based Optimiser (CBO) only. The CBO uses optimiser statistics in determining the execution plan for a query.

This topic is described fully in [ORATUN] and only a brief summary is given here. By default, Oracle automatically collects a set of optimiser statistics, using a batch job that runs in the maintenance window.

Before NHHDA is started for the first time following an upgrade to 11g, it is necessary to issue commands to collect statistics manually, as specified in [NINGDE] Appendix E. Note that this includes instructions to run specific commands to collect histogram statistics on certain columns where the distribution between possible values is skewed; it was found that Oracle did not automatically collect this information.

With the upgrade to 11g, the onus for optimising performance has shifted to some extent away from the application designer towards the DBA. The CBO will take different decisions for different NHHDA instances, depending on the size of the NHHDA database, the configuration settings in the Oracle Initialisation Parameter file (init.ora) and the configuration of the hardware that it is running on. Therefore an NHHDA instance may experience specific performance issues which no other instances encounter; under such circumstances it may not be possible for the SVACSS organisation to issue an NHHDA patch to address the problem.

6 System Organisation

This section contains information on the structure of the NHHDA system in terms of directories and files; lists the environment variables that have been created for the NHHDA system; describes the batch queues that are used by the Scheduler subsystem.

6.1 Directory Structure

The following directory structure is created on installation of the NHHDA application software:

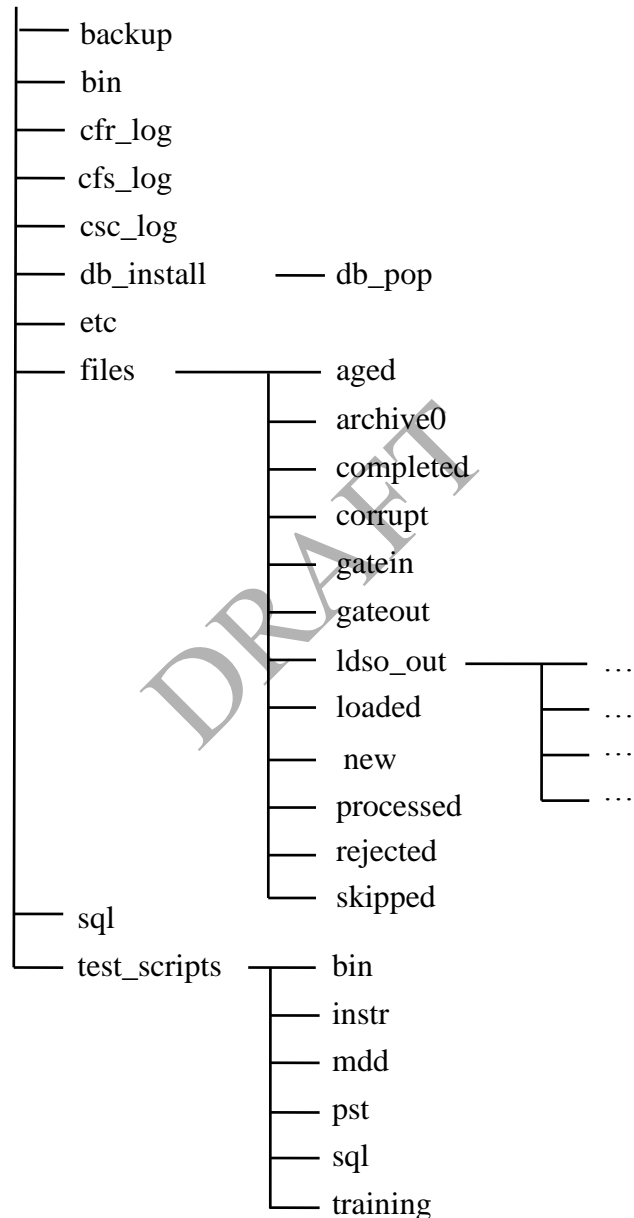

Figure 11: NHHDA Directory Structure

NHHDA application software executable files are stored in the ‘bin’ directory. Scheduler logs, (described in section 11.2), are stored in the ‘csc_log’ directory. The actual directory is specified in the ‘cdb_system_parameter’ table, described in section 7. The ‘db_install’ and ‘etc’ directories contain files that are used during installation of the

NHHDA application software. The 'sql' directory contains example sql scripts. The cfr_log and cfs_log directories contain logs that record background processing of the File Receipt and File Send processes respectively.

To support file and space management, symbolic links can be defined, using Operating System functionality, from the directories under 'files' to directories on other disks. This may be important where the directories contain significant volumes of data. When setting up symbolic links, you should consider how files are moved to various directories depending on the file type/file status combination, as defined in the cdb_default_directory (described in section 6.3). It may be of benefit to ensure that directories between which files are frequently moved are located on the same disk; for example, by defining a symbolic link from one directory to the disk on which the other directory is stored. For further discussion of file status changes, refer to the NHHDA Operations Guide.

The cdb_file_directory table holds the Operating System path of the directories that make up the local file store (under the 'files' directory) and indicates the directories to be searched for the arrival of new files.

The ldso_out directory will be defined in the cdb_file_directory table, and it will contain directories that hold EAC Data to Distributor reports (P0222). The ldso_out sub-directories will be named using the short code used to identify a Market Participant who has the Distributor role; the directories only contain files for that Participant. The ldso_out structure is intended to make the identification of files which will be manually distributed easier.

The cdb_file_directory table is initially populated through SQL during system installation. Refer to the NHHDA Installation Guide for further information. No facilities are provided to maintain this table through the user interface.

The Source Directory field is set to true if this is a directory that should be scanned by the File Receipt Manager when looking for incoming files.

For an online directory, the path is the POSIX path for the directory. If the directory has been also written to long-term media for archive, the archive_media field is a reference to identify the media used (otherwise it is null). If the directory has been deleted (but is retained on archive media), then the path will be set to null.

6.2 File Names

For files received from the Gateway, the filename should be unique across all possible sources and for POSIX compliance, must be 14 characters or less. When a file is received by the NHHDA application software, it moves and renames the file, giving it a different unique filename. The receipt of a file with the same original name as a file that has not yet been moved will result in the loss of data contained in the first or both files.

For files sent to the Gateway, filenames are unique within the installation of the NHHDA application software. The format of filenames is as follows:

```
<market participant role code><market participant id><9
digit file_id>
```

6.3 File Locations

The cdb_default_directory table records the directory into which a file, of a particular file type, is placed when it changes to the specified status.

This table is used by a number of the file handling processes within the NHHDA application software. For example, by the File Receipt Manager for determining where to place files that are received by the system.

The table is initially populated using SQL during system installation. Refer to the NHHDA Installation Guide for further information. There is no user interface provided to maintain this table. The value for “directory_id” can be amended using interactive SQL.

The following table identifies the File Type and Status combinations in cdb_default_directory that are used by the NHHDA application software. For each combination of File Type and File Status, there is a “directory_id” identifying the directory where files of that type and status are placed.

File Type	Description	File Status
L0000001	Unrecognised or unreadable file	Default Received Archived
D0023001 D0041001 D0095001	Failed Instructions Supplier Purchase Matrix Data Collector Exceptions Log Data File	Default New Completed Sent Archived
L0001001 L0003001 L0004001 L0005001 L0009001 L0040001 L0011001 L0012001 L0013001 L0014001 L0015001 L0016001 L0017001 L0044001 L0020001 L0032001 L0033001 L0034001 L0037001 L0038001	Audit Log Human-readable reports Operator Log Error Log Load Timetable Exceptions Report Load MDD Exceptions Report GSP Group and Associated Items Report Standard Settlement Configuration Report Average Fractions of Yearly Consumption Report Distributors Report Metering Systems and Associated Items Report Instructions Report Data Aggregation Run Report MS History, EACs and AAs Report Profile Class Report Supplier Purchase Matrix Report Data Collector Exception Log Report Aggregation Exception Log Report Aggregation Exceptions Log Aggregation Run Log	Default New Completed Archived

File Type	Description	File Status
D0269002 D0286001	Market Domain Data Complete Set Data Aggregation and Settlement Timetable File	Default Received Rejected Running Processed Archived
D0019001 D0209001	DC Instruction File PRS Instruction File	Default Received Rejected Running Loaded Processed Skipped Corrupt Archived
L0039001	PRS Refresh temporary file	Default
L0043001	DC Performance Report	Default Archive
P0147001	DC Summary Report	Default Archive
L0051001 L0052001	Intermediate NDP Data File Intermediate NDP Exception Log	Default New
L0053001	EAC To Distributor Exception Log	Default New Completed Archived
P0222001	EAC To Distributor Report	Default New Completed

If the Status in `cdb_default_directory` is “default”, then files with the corresponding file type are placed in the associated directory regardless of their status.

A File Type of ‘L0000001’ (error) and Status of “received” is used to manage unreadable or unrecognised files, when:

- the filename or file header cannot be decoded or validation checks fail;
- an unrecognised file type is received (ie: there is no corresponding row in the `cdb_file_processing` table).

Files with a file type of L0039001 are temporary files created by the PRS Refresh batch process. If the PRS Refresh completes successfully, these temporary files, and their associated entries in the `cdb_file_reference` table are deleted. Under such conditions, the temporary files are not visible via the Browse File Extraction and Transmission Statuses form (refer to the NHHDA Operations Guide for further information about this form). While a PRS Refresh is being applied, or if a PRS Refresh has failed, the

temporary files and references to such files, in the `cdb_file_reference` table, are visible via the Browse File Extraction and Transmission Statuses form with a status of 'new', though they cannot be selected from the Type list of values.

Temporary files may not be deleted if a PRS Refresh fails. See section 14.5 for further information.

Files with a file type of L0051001 and L0052001 are temporary files created by the NDP process. If the NDP process completes successfully, these temporary files, and their associated entries in the `cdb_file_reference` table are deleted. Under such conditions, the temporary files are not visible via the Browse File Extraction and Transmission Statuses form (refer to the NHHDA Operations Guide for further information about this form). While a NDP report is running, or if a NDP report run failed, the temporary files are visible via the Browse File Extraction and Transmission Statuses form with a status of "new".

The file type P0222001 will be manually distributed and will not be visible via the Browse File Extraction and Transmission Statuses form. The files can only be accessed from `ldso_out` in the NHHDA application directory structure, refer to section 6.1. The location of the `ldso_out` directory can be changed by altering the path stored in the NDPD domain, refer to section 5.5.

6.4 Receiving files - `cdb_file_processing`

This table contains details of the file types to be handled by CFR. A row exists for each file type, the corresponding activity invoked to process the file and a flag to indicate whether the file should be processed automatically upon receipt.

When processing of a particular file type is initiated manually, the corresponding row should have `auto_process` set to 'N'. This is the default setting upon installation. To enable automatic processing for a particular file type, the corresponding row should have `auto_process` updated to 'Y'.

If the automatic processing of files is enabled the following points should be noted.

- The NMI system could hold up Form processing. For example, if the queue widths for instruction processing sub-activities are optimal, the processing will impact interactive users. This is hard to quantify as it would depend on what the users are doing.
- Instruction files arriving out of sequence will not be processed (the load will report the fact and leave the file in 'received' state and each time instruction processing is invoked the check will be repeated). They will subsequently be processed when the missing instructions arrive, but users should be aware of the extra error messages this will cause.
- If one or more files arrive late in the day, the processing activities may still be running when the system manager wants to shut the database down in preparation for overnight processing. There is no need to wait for completion as stopping NHHDA will abort the

current processing, leaving it ready to be resumed later. Once the database has been restarted in restricted session mode, the overnight schedule should be as for manually processing files (i.e. starting with instruction processing) to ensure any outstanding processing is carried out prior to aggregation.

- If batch jobs are scheduled one by one, waiting for the first to complete before submitting the next, then the arrival of an instruction file during instruction processing will cause an additional processing activity to run as soon as the 'scheduled' activity has completed. This will merely hold up the start of aggregation. If batch jobs are all submitted at the start of overnight processing, a new file arriving will submit a processing activity which will run after all overnight batch jobs complete.
- Note that any instruction processing activity which starts after aggregation will abort due to the database lock. It is desirable, therefore, that after the database backup and unlock have been performed instruction processing is submitted to ensure any files which have arrived overnight are processed (this could be part of the start of day procedures).
- The batch processes should have the queue width for sub-activities set to optimal to maximise performance. As mentioned above, this could have performance implications on interactive users if the queue width is not lowered again during the day. This is dependent upon the machine and the activities being performed.

6.5 Sending files - `cdb_export_configuration`

When a file is sent to another market participant, the system uses the database table `cdb_export_configuration` to determine where to send the file. The mechanism for sending is configurable - the script `cfs_send` may be changed to behave in a manner appropriate to each installation.

When a file is to be sent, the database looks in `cdb_export_configuration` for an entry matching the file type, market participant and market role appropriate. If a record is found which matches `file_type`, `market_role` and `participant_id` then this is used; if there is no matching record, the system looks for an entry which matches `file_type` but has null `market_role` and null `participant_id` instead. If neither attempts finds a record, `cfsd`, the file sender daemon process, logs the problem and does not attempt to send the file. If a match is found, then the script `cfs_send` is invoked passing the following parameters:

1. LOG DIRECTORY - a writable directory which may be used by the script to redirect output. Any files created in this directory should be deleted by the script
2. FILE ID - the unique identifier of the file being sent
3. GATEWAY - the gateway field from the record in `cdb_export_configuration` as determined above.

4. FILE NAME - the name of the actual file to send
5. SOURCE DIRECTORY - the path where the file is. The script must copy the file from here.
6. DIRECTORY - the directory field from the record in cdb_export_configuration as determined above.

The default cfs_send script uses ftp to connect to gateway, change directory to directory and copy the file called file name from source directory to the remote machine. The output from the ftp session is redirected into log directory and then scanned for a success message. In the event of failure, this output file is then displayed (it will appear in the cfs_log file). Cfs_send returns 0 for success (in which case the status of the file will be updated to 'sent' and the process_send_time in cdb_file_reference will be set); cfs_send returns non-0 in the event of failure.

6.6 File Sizing

The following table shows the sizes of the files used by NHHDA. All sizes are based on the NHHDA Requirements Specification:

- 10,000,000 metering systems
- 270,000 instructions per day (based on logical design)
- 48,000,000 supplier purchase matrix cells

All database fields are assumed to be fully filled with data. All reports are run on a totally ad hoc basis so no volumetric information can be derived for these files.

Name	Record Length (bytes)	Number of Records per Copy	Average Number of Copies per Day	Approx. Daily Volume (Mb)
Instruction Input File	137	270,000	1	37
Instruction Audit Information	200	270,000	1	54
Aggregation Exception Log (machine format)	40	10,000,000	8	3,200
Check data collector data (machine format)	40	10,000,000	1/14	29
Supplier Purchase Matrix	119	48,000,000	8	45,000
Failed Instructions	50	27,000	1	1
Total				48,321

The number of Metering Systems and SPM cells is very high and in practice it is unlikely that these numbers of records will ever be reached. More realistic numbers are 3,000,000 meters, 80,000 Instructions and 10,000 SPM cells. Using these figures, the estimated sizes of files are as follows

Name	Record Length (bytes)	Number of Records per Copy	Average Number of Copies per Day	Approx. Daily Volume (Mb)
------	-----------------------	----------------------------	----------------------------------	---------------------------

Name	Record Length (bytes)	Number of Records per Copy	Average Number of Copies per Day	Approx. Daily Volume (Mb)
Instruction Input File	137	80,000	1	11
Instruction Audit Information	200	80,000	1	16
Aggregation Exception Log (machine format)	40	3,000,000	8	960
Check data collector data (machine format)	40	3,000,000	1/14	9
Supplier Purchase Matrix	119	10,000	8	10
Failed Instructions	50	8,000	1	1
Total				1007

6.7 Configuring Temporary Files

During an aggregation run the Unix kernel requires a number of temporary files to be open. The number that this should be set to can be calculated from the following formula:

Each NAR CI process will have the following:

For each run

1 exception file

1 audit file (if audit turned on)

10 intermediate files

The number of NAR CI processes will be determined by the NAR CI queue width.

So, for a q width of 4 and 4 runs you will have

$4 * 12 = 48$ files open for writing per process, 192 in all

NB: There will also be files opened by Oracle.

6.8 Batch Queues

An Exclusive queue has been configured, on which only one batch process can run at any one time. This configuration ensures that there are no conflicts between the Instruction Processing, Data Aggregation and Check Data Collector batch processes.

When one of these batch processes is initiated by the Scheduler, it keeps an active entry on the Exclusive queue, while submitting multiple sub-processes to non-exclusive queues to perform the processing. The non-exclusive queues configured for the NHHDA system are as follows:

- NARCDB
- NAR_CI
- NAR_AD
- NAR_GO
- NCD_CE

- NCD_GO
- NDP_CI
- NMIARR
- NMIAPP
- NMIRET
- NMIRFR
- NMIRFT
- NREPORT
- CRPFMT

To ensure that Instructions from the same Market Participant are processed in a single stream, a controlling process, running in the Exclusive queue, manages the arrival of Instruction files. This process submits an 'Instruction File Arrival' job for each new Instruction file in order and waits for these to complete. Once these activities are complete, the controlling process submits an 'Apply Instructions' process for each Instruction file originator. Once these activities are complete, the controlling process completes.

Queue widths can be modified by the NHHDA Oracle User, (this user is set up during installation; refer to the NHHDA Installation Guide, section 2.2.5.2 for further information), using SQL on the cdb_queue database table.

The size of the queue widths for the following queues should be configured to be the same as the number of processors in the system configuration:

- NCD_CE
- NARCDB
- NCD_GO
- NMIRFT

The queue widths of the following queues can be set to the number of partitions/2, with a lower limit of the number of processors and an upper limit of the number of processors*2. Typically this will be the number of processors.

- NAR_CI
- NAR_AD
- NAR_GO
- NDP_CI
- NMIAPP
- NMIRFR
- NMIMIF
- NREPORT
- CRPFMT

The following queue widths should be set to a value of 1:

- NMIARR (this could be set to 2 but may occasionally cause Oracle deadlocks)
- NMIRET

Note that the benefits of some of the queues will only be realised if each of the database partitions is on a different disk. Note also that conflicts between the processes using these queues may occur if the queue widths are increased beyond the number of processors.

6.9 Locations of Aggregation Intermediate Files

The first stage of the Data Aggregation process is to calculate aggregation increments for a set of metering systems from the NHHDA database.

These aggregation increments are written to temporary intermediate files, which are deleted at the end of the Aggregation Run.

The location of these intermediate files can be configured, using SQL, by amending the `ndb_nar_file_location` database table. The primary key of the table is partition id. For each row in the table, you can specify the directory in which the intermediate files are stored during a data aggregation run.

6.10 NHHDA Processes

The processes of the NHHDA application software are as follows:

- `cfrd` - File Receipt Daemon (background process)
- `cfsd` - File Send Daemon (background process)
- `clgd` - Logger Daemon (background process)
- `crpfmt` - Report Formatter
- `cscd` - Scheduler Daemon (background process)
- `nar_pc.exe` - Aggregation (controlling process)
- `nar_ci.exe` - Aggregation (calculates increments for the cells in Supplier Purchase Matrices for scheduled aggregation runs and stores them in flat files)
- `nar_ad.exe` - Aggregation (aggregates data for a set of Metering Systems from the flat files created by `nar_ci.exe` and generates the machine readable DC Performance Report)
- `nar_go.exe` - Aggregation (writes Supplier Purchase Matrix files for a data aggregation run)
- `archive.exe` - Archive
- `arc_dbs.exe` - Archive (archives schedule based database data)
- `ncd_pc.exe` - Check Data Collector Data (checks all metering system data from PRS Agents and Data Collectors)
- `ncd_ce.exe` - Check Data Collector Data (calculates exceptions in Data Collector data for all Settlement Registers in the NHHDA database)

- ncd_go.exe - Check Data Collector Data (generates exception output files)
- nld.exe - Load Data Files
- nmi.exe - Instruction Processing
- naf.exe - Average Fraction of Yearly Consumption Report
- dars.exe - Data Aggregation Run Schedule Report
- gsp_grp.exe - GSP Groups Report
- instruc.exe - Instructions Report
- distrib.exe - Distributors and Associated Items Report
- msai.exe - Metering Systems and Associated Items Report
- ms_hist_eac_aa.exe - MS History, EACs and AAs Report
- pro_cls.exe - Profile Class and Associated Items Report
- sscai.exe - Standard Settlement Configurations and Associated Items Report
- supplier_pm.exe - Supplier Purchase Matrix Report
- dc_except.exe - Data Collector Exception Report
- agg_except - Aggregation Exception Report
- dc_summ_except.exe – Data Collector Summary Report
- dump_audit.exe - Unload Audit (unload audit data from audit database tables to flat files)
- ndp_pc.exe - EAC Data for Distributor report (controlling process)
- ndp_ci.exe - EAC Data for Distributor report (retrieves metering system data from the database for Distributors requesting the EAC Data report)

7 System Parameters

The NHHDA system uses a number of System Parameters, which are stored in the `cdb_system_parameter` table.

The System Parameters shown in the table below can be modified using the Maintain System Parameter Values form, which is described in the NHHDA Operations Guide. Any changes to System Parameters are recorded in the NHHDA Audit Log. Refer to section 9 for further information about the Audit Log. Note that additional System Parameters, which cannot be modified and are not shown below, are used by the NHHDA application software to store the dates on which archiving of different tables and Operating System files was last performed.

The default values for the maintainable parameters are also given.

It is important that if any system parameters with a default numeric value are modified, the new value is numeric. Failure to do so may result in unexpected results:

- *If a default numeric value is modified such that the first character is non-numeric, eg. B3, the parameter will be interpreted as zero.*
- *If a default numeric value is modified such that part of the value is non-numeric, eg. 3W55, the parameter will be interpreted as only the digits preceding the non-numeric characters.*

The Parameter column below shows the values of `param_type` and `param_type2` from the `cdb_system_parameter` table. The combination of these two values provides a unique parameter reference.

Parameter	Description	default value
ARP/DBA	Activity based DB data period The number of days between successive archiving of data stored in the <code>cdb_activity</code> and <code>cdb_activity_parameter</code> database tables. Refer to section 12 of the NHHDA System Management Guide for further details.	3
MDP/MDA	Advance Period for MDD Load The number of days in the future that MDD data will be considered valid. Any data with an Effective From Date > {Current System Date} + {MDD Advance Load Period} will be ignored and not be loaded.	90
NAR/AAV	Aggregate All Valid GSP Groups When set to TRUE, Aggregation will use all valid GSP Groups on the system and report Metering Systems totals to the Operator Log at the end of Aggregation. Also, the GSP Groups scheduled will be amended to reflect those actually used in the run and any changes to the schedules reported to the Operator Log.	TRUE
ARP/FAU	Audit log retention period The number of days between successive archiving of audit logs. Refer to section 12 of the NHHDA System Management Guide for further details.	2

Parameter	Description	default value
ARP/FCE	<p>CDCD exception period</p> <p>The number of days between successive archiving of Check Data Collector Data exception logs. Refer to section 12 of the NHHDA System Management Guide for further details.</p>	7
CSC/CLD	<p>Closedown timeout (secs)</p> <p>The delay in seconds between requesting scheduler closedown and exit</p>	20
ARP/DBF	<p>DB File reference period</p> <p>The number of days between successive archiving of data held in the File Information tables (except <code>cdb_file_processing</code>) listed in section 5.1 of the NHHDA System Management Guide. Refer to section 12 of the NHHDA System Management Guide for further details.</p>	1500
NDB/DBN	<p>Days before Notification</p> <p>In a Data Aggregation Settlement Timetable, the number of working days for which a data aggregation run is scheduled prior to an ISR Notification deadline date.</p>	2
ARP/FCS	<p>DC Exception Summary retention period</p> <p>The number of days between the archiving of DC Exception summary report files, both machine and human readable</p>	5
ARP/FDC	<p>DCP retention period</p> <p>The number of days between successive archiving of DC Performance files. Refer to section 12 of the NHHDA System Management Guide for further details.</p>	5
ARP/FER	<p>Error Log Period</p> <p>The number of days between successive archiving of Error Logs. Refer to section 12 of the NHHDA System Management Guide for further details.</p>	7
ARP/FEX	<p>Exception period</p> <p>The number of days between successive archiving of: Data Aggregation Run Exception log; Load SSC Exception Log; Load Data Aggregation Settlement Timetable Exception log. Refer to section 12 of the NHHDA System Management Guide for further details.</p>	7
ARP/FFI	<p>Failed Instructions period</p> <p>The number of days between successive archiving of failed Instructions. Refer to section 12 of the NHHDA System Management Guide for further details.</p>	2
ARP/FIS	<p>Instruction Data Retention Period</p> <p>The number of days between archiving of instruction data rows.</p>	30
CFR/FRT	<p>File Receipt Timeout (secs)</p> <p>Time after which an incoming file without a footer is deemed to be corrupt. If this parameter value is too low, a large file that takes some time to arrive may be marked as corrupt, even though it has a footer, because the footer arrives after the timeout period</p>	3600

Parameter	Description	default value
CFS/ALT	File Send Alert Timeout (seconds) Time after which the File Send daemon wakes up if no new file sends are requested, and hence rechecks for files needing resending	10
ARP/FID	Incoming Data File period The number of days between successive archiving of incoming data files. Refer to section 12 of the NHHDA System Management Guide for further details.	2
ARP/FIN	Instruction File period The number of days between successive archiving of Instruction Files. Refer to section 12 of the NHHDA System Management Guide for further details.	28
CSC/LOG	Log Directory The directory in which the Scheduler logs are generated. This must be a valid directory and can be either an absolute path or in relation to the directory where the NHHDA executables are installed	../csc_log
NAR/AUD	NAR Audit Log Enabled Sets on and off generation of the Aggregation Run Log. Valid values for this parameter are: enabled disabled ENABLED DISABLED	disabled
CFS/NFS	Number of retries Number of attempts by the File Send Process to send a file	3
ARP/FOP	Operator log period The number of days between successive archiving of Operator logs. Refer to section 12 of the NHHDA System Management Guide for further details.	7
CLG/PTM	Pipe timeout (seconds) Time after which if there is no response from the logger the application assumes that the logger daemon is dead	5
CFR/PFQ	Poll frequency (seconds) The number of seconds between polling of the incoming file directory by the File Receipt process	5
ARP/DAG	SPM DB table period Number of days between successive archiving of Supplier Purchase Matrix data in the database. Refer to section 12 of the NHHDA System Management Guide for further details.	900
ARP/FSP	SPM retention period The number of days between successive archiving of Supplier Purchase Matrices. Refer to section 12 of the NHHDA System Management Guide for further details.	5

Parameter	Description	default value
CSC/LCK	Schedule Lock The name of the lock of the Scheduler. This would be used in the unlikely event of more than one instance of the Scheduler running on a particular server. For example, if the NHHDA and ISRA application software are both running on the same server.	<User Name>_CSC_LOCK
ARP/DBS	Schedule based DB data period The number of days between successive archiving of Settlement based db data. Refer to section 12 of the NHHDA System Management Guide for further details.	900
CSC/ALT	Scheduler Alert timeout (seconds) Time between successive polls for scheduled activities	10
SYS/ORG	System Organisation Name Name of the organisation operating the NHHDA system	(defined at installation)
CFS/NRT	Time between retries (secs) Number of seconds between attempts by the File Send Process to send a file to the gateway	30
ARP/FUK	Unknown File Retention Period The number of days between successive archiving of files unrecognised by the NHHDA application software. Refer to section 12 of the NHHDA System Management Guide for further details.	7
NDB/URF	Use Run Date from File The Data Aggregation Run Date is calculated as “Days before Notification for Aggregation Run” working days before the corresponding ISR Notification Deadline Date. (If it is ‘TRUE’, the date held in the Planned Data Aggregate Run Date field of the Data Aggregation Settlement Timetable Details record is used as the Data Aggregation Run Date.	FALSE
ARP/FUR	User report period The number of days between successive archiving of machine- and human-readable reports. Refer to section 12 of the NHHDA System Management Guide for further details.	2
NDB/VCD	Valid Calendar Days for Run The maximum number of calendar days prior to an ISR Notification deadline date for which a Data Aggregation Run can be scheduled without returning a status of ‘error’ or Failed.	15
CRP/WFS	Warning file size (bytes) During an attempt to view a file, if the file size exceeds the warning file size the user will be prompted with a message to either continue or cancel the display of the file.	50
<u>NMI/EUB</u>	<u>EAC Upper boundary value</u> <u>If the received EAC value is greater than the EAC upper boundary value, the respective instruction will be rejected with the failure reason code NIV</u>	<u>100,000,000.0</u>

Parameter	Description	default value
<u>NMI/ELB</u>	<u>EAC Lower boundary value</u> <u>If the received EAC value is less than the EAC lower boundary value, the respective instruction will be rejected with the failure reason code NIV</u>	<u>-100,000,000.0</u>
<u>NMI/AUB</u>	<u>AA Upper boundary value</u> <u>If the received AA value is greater than the AA upper boundary value, the respective instruction will be rejected with the failure reason code NIV</u>	<u>100,000,000.0</u>
<u>NMI/ALB</u>	<u>AA Lower boundary value</u> <u>If the received AA value is less than the AA lower boundary value, the respective instruction will be rejected with the failure reason code NIV</u>	<u>-100,000,000.0</u>

The following System Parameters can be defined during installation using SQL, and cannot be maintained via the NHHDA user interface:

- **SYS/ BSD - BETTA Start Date**
The date from which BETTA rules will be implemented in NHHDA. Used to control the recipient of the SPM files before and after implementation of BETTA. For settlement dates before the BETTA Start Date, the ISR Agent for Scottish GSPs will be that stored in the 'SPI' system parameter. For settlement dates on or after the BETTA start for Scottish GSPs, the ISR Agent appointments will be set-up via MDD files or the GSP groups form, in the same way that English & Welsh GSP group ISR Agent appointments are set-up.
- **SYS/SPI - Scottish Participant ID**
The participant to which the SPM files should be sent for Scottish GSP groups, for settlement dates prior to the BETTA Start Date.
- **System Organisation Name**
- **System Participant Id.**
- **NDP/ADI - NDP archive directory id**
When the NDP process completes successfully all the EAC Data to Distributor reports generated are marked as archived and will reference this directory id. The cdb_file_directory record for the directory id will be used to indicate that files which reference it were not archived by the archiving process. The directory id record in cdb_file_directory will have the archive_media field set to "ldso_out_arch" and the path set to null. Changing this parameter would also require a change to the cdb_file_directory table.
- **NDP/PDL - Previous days request limit**
The value is used by the EAC Data to Distributors Report form to validate the date for a report request. The EAC Data to Distributors report request needs to be run for a date close to the current date to be able to identify relevant EAC values; an EAC will usually be

superseded by an AA value for a metered system. The parameter limits the number of days in the past that a report can be request for.

Refer to the NHHDA Installation Guide Section 2.2.5.3 for further information.

DRAFT

8 User Accounts, Privileges and Security

The NHHDA system provides three levels of security:

- Server Operating System;
- Oracle database tables;
- Oracle forms.

Operating System accounts control access to server files and processes while Oracle roles are used to control access to Forms and database tables.

8.1 Server Operating System

The Operating System controls server access through user accounts consisting of a logon name and a password. These accounts are set up by the System Manager. The concept of groups is supported such that users needing similar access to the system and associated files/directories can be allocated to the same group. For example, an Operator user group can be created with a number of operator users each having a distinct name and password but having common access rights to files.

Each user requiring direct access to the server requires an Operating System account. Server file permissions need to be set to ensure that file access is limited to those applicable to the user role, eg. prevent deletion or modification of certain files. By default, the 'batch' user set up during installation, has read, write and execute permission on files stored under the \$RUNTIME directory, (the directory specified by \$RUNTIME is a sub-directory of the 'batch' user's home directory and is defined during installation; refer to the NHHDA Installation Guide for further information). All other users have read-only access to these files. The Oracle user also needs read-only access to several directories. These directories are detailed in the NHHDA Installations Guide. Most users should not require direct access to the server, and discretion should be used in allocating Operating System accounts.

The mechanism by which this is achieved depends on the Operating System security features available. For example:

- File Permissions, as included in the POSIX standard (P1003.1), or
- Access Control Lists, as supported by the POSIX security extension (P1003.1e/2c - previously known as POSIX.6).

A terminal session on the server may be established from the client. This is equivalent to direct Operating System level access. Such connections are limited to those users who have Operating System user accounts.

NHHDA batch processes are run by the 'batch' user.

Any resulting Operating System files (e.g. outputs) will be owned by the 'batch' user. However, access for other users may be granted by having default access set for the directory in which the output files are written. In this way wider access may be granted as necessary.

The actual user submitting the batch process will be recorded in the `cdb_activity` table and logged in the Operator log. This allows tracking of processes initiated by specific users.

8.2 Oracle Database Tables

Standard Oracle account names and passwords are used for two aspects of system security:

1. To ensure that only valid NHHDA users have access to the NHHDA system;
2. To assign each NHHDA user type with appropriate privileges for Oracle objects such as tables and views.

Users accessing the system from the client will be required to supply an Oracle account name and password to establish a connection to the database running on the server. The Oracle account will be associated with one or more default Oracle roles giving the user access permissions to the tables and the Forms (as described in the following sections).

Oracle supports the concept of roles which enable access control to be established at the database table level.

Oracle roles are set-up with specific table access privileges. Each role having a combination of Create, Read, Update or Delete privileges for each table they have access to.

Each Oracle user is defined as having certain (default) roles. On logging on to the database, the access granted is based on the combination of roles defined (ie: the sum of all privileges associated with the default roles)

These access privileges are enforced at database level on all accesses to a table. Thus accesses from Oracle Forms, batch processes and SQL all carry out the same authentication.

The following NHHDA user roles are Oracle roles and are defined as default in the NHHDA system:

User Role	Description
DATA_AGG_ADMIN	Data Aggregation Administrator
MKT_DMN_DATA_ADMIN	Market Domain Data Administrator
SUP_MKT_DMN_DATA_ADMIN	Superior Market Domain Data Administrator
EXCEPTION_ADMIN	Exception Administrator
SYSTEM_OPERATOR	System Operator
SYSTEM_MANAGER	System Manager
AUDITOR	Auditor

Each user can be assigned one or more of the NHHDA roles.

Each NHHDA role has a combination of Create, Read, Update or Delete privileges for each table to which the role has been granted access. A user has access to the database tables according to the combined privileges of the assigned roles.

The NHHDA Maintain User Oracle form can be used to create users and grant or revoke Oracle roles to users, either at the time of user creation or at any later time.

A ‘batch’ user, used by NHHDA batch processes, is set up as Operating System authenticated, thus avoiding any password being hard coded in the application.

8.3 Oracle Forms access

Access to Oracle Forms is also controlled by the use of Oracle roles. The concept of menu security for controlling access is applied to Oracle Forms by associating roles with menu items. This allows appropriate functions to be made available to a given role, whilst others will see the menu items as ‘greyed out’ and not available.

Generally, forms that update the database should only be made available to users who have the necessary privileges on the underlying database tables. However, in some cases the same form will be made available to other users, with only read only access to the underlying tables, to allow data to be viewed. If such users attempt to commit a change, it will be rejected by the underlying database access control restrictions and a message will be displayed to the user indicating that the change has not been made.

Refer to the NHHDA Operations Guide for details of user role access to NHHDA menus.

8.4 Password Management Through Oracle Profile

The “PROF_NHHDA” profile is defined with password management attributes to control access to the system depending on the status of the password. This is assigned to all users created through the Maintain User Oracle form.

8.5 Maintain User

To enable access to the NHHDA application software an Oracle user account is required. A new user account can be created either through the Maintain Users Oracle Form or by creating the user manually using below steps:

1. Create a new Oracle account for the user, if the user does not already have one;
2. Assign one or more of the NHHDA User Roles to the user, as listed in section 8.2. The user will have access to database tables and Oracle forms according to the combined user roles.
3. Assign the “PROF_NHHDA” profile to the user to apply the password management properties.

The Maintain Users Oracle form additionally offers the functionality to control the access on user accounts by changing the password and/or changing the account status to Locked or Unlocked or Expired, also changing the account status to Unexpired which requires a new password to be entered. The Maintain Users Oracle form can also be used to grant and/or revoke the application roles.

An advantage of using the Maintain User form is that user creation, user deletion, and grants and revokes of user roles are audited.

8.6 Breaches of security

The security features provided by the Operating System control all attempts to logon to the server. These features will be used to monitor and log access to the system.

Access to the Oracle database is controlled using Oracle accounts and roles. Oracle auditing can be used to monitor and log access to the database. In particular, “audit session” can be used to record successful and/or unsuccessful attempts to connect to the database.

Any user attempting to use the AUDIT command must have AUDIT SYSTEM privilege. The Initialisation parameter AUDIT_TRAIL must be set in the database initialisation file, to “OS” for the Operating System option.

DRAFT

9 Auditing

Updates to data held in the NHHDA database are recorded for audit purposes and for assistance in resolving queries on a day to day basis. Audit records are created following:

- changes to data via the user interface, such as Pool Market Domain Data;
- changes to data as a result of batch data file processing. Note that during Instruction processing, the only audit information logged is for updates to `ndb_instructions` and `ndb_instruction_status_reason`.
- creating user, dropping users, granting roles to users and revoking roles from users via the Maintain User form

Audit records are created following changes to the following tables:

- `cdb_system_parameters`
- `ndb_av_frac_y_cons`
- `ndb_data_agg_runs`
- `ndb_gsp_groups`
- `ndb_gsp_groups_dis`
- `ndb_gsp_groups_run`
- `ndb_gspg_pc_av_eac`
- `ndb_isr_agent_apps`
- `ndb_llf_classes`
- `ndb_m_participants`
- `ndb_measure_reqs`
- `ndb_profile_classes`
- `ndb_settlements`
- `ndb_std_sett_cfgs`
- `ndb_threshold_pars`
- `ndb_t_p_regimes`
- `ndb_vsscpcs`
- `ndb_check_dc_data_runs`
- `ndb_instructions`
- `ndb_instruction_status_reason`
- `ndb_refresh_instr_failure`
- `ndb_refr_instr_failure_reason`

and to the `ndb_user_roles` view (only the following changes are audited, and only if they are done via the Maintain User form: adding a new user; dropping a user; granting a role to a user; revoking a role from a user).

Audit data is initially written to a set of database tables.

A batch process, run on a daily basis, writes out the contents of these tables to an audit log.

9.1 Audit Database Tables

Audit data is initially written to the database tables `cdb_audit_n` and `cdb_audit_fields_n`. The value of 'n' is between 1 and 7; a separate table is written for each day of the week.

The `cdb_audit_n` table records information about which table has been updated, and the type of update, eg. deletion, creation. For each record in the `cdb_audit_n` table, the `cdb_audit_fields_n` table records which fields have changed; for creation of a new row and update of a field in an existing row, the values of *all* fields in the row are recorded. If the prime key fields of a row in a table are changed, two audit entries are created in the audit table, a delete entry and a subsequent creation.

Each day, a batch process can be run which reads the sets of tables that are not in use, writes out their contents to structured files and deletes the corresponding database entries. To perform this housekeeping task, execute the following command from the operating system command line:

```
nhh_submit.exe u
```

If access to the data held in the `cdb_audit_n` and `cdb_audit_fields_n` tables is required, eg. using SQL, before generating the Audit Logs from these tables, the following should be noted. In the `cdb_audit_fields_n` tables, a field of an audited table is identified by the column it occupies in that table. For example, an audit of the `ndb_instructions` table includes the `instr_seq_no` (Instruction sequence number) as field number 1, as it occupies the first column in the `ndb_instructions` table. To map the field numbers used in the `cdb_audit_fields_n` tables to the field names, refer to Appendix C of the NHHDA Technical Specification.

9.2 Audit Log Files

Audit log files have the following name format:

```
<role code><participant id><9 digit file_id>
```

eg. for Data Aggregator "XXXX" a file might be named:

```
DXXXX123456789
```

The location of Audit Log files in the local file store is defined in the `cdb_default_directory` table. These logs are therefore easily distinguishable from other log files.

The audit log files produced are read-only files which can be searched using Operating System tools such as 'grep' and 'vi' to identify all changes made to the database.

The header of the Audit Log identifies the operator of the NHHDA system, and the creation time of the Audit Log.

The body of the Audit Log contains the following information:

- **Record Type** - a 3 character code that identifies the audited table. A list of these codes is shown in the table below;
- **Modification Time** - the time at which the auditable change was made;
- **Modification Type** - the type of modification, one of 'I' (Insert), 'U' (Update), 'D' (Delete);

- **User** - the user who performed the change to the data. In the case of data changes resulting from batch processes, the user is identified as 'Batch';
- **Field Value 1** - the first field of the table identified by the Record Type code, which has been subjected to one of the changes identified in Modification Type at the Modification Time by the User;
-
- **Field Value n** - the nth field of the table identified by the Record Type code, which has been subjected to one of the changes identified in Modification Type at the Modification Time by the User. Where the operation being audited is a user/role grant/revoke, then for the role fields in the NDB_USR_ROLES view, the Field Value consists of "G:" (grant) or "R:" (revoke), followed by the name of the role .

The number of Field Values in each record of an Audit Log depends on the Record Type, ie. the number of fields in the database table to which that row refers. To identify the column headings of the Field Values recorded in an Audit Log, refer to Appendix C of the NHHDA Technical Specification, using the table below to identify which table is recorded in the log.

The following table shows the possible Record Types for the NHHDA system:

Table Name	Record Type
cdb_system_parameters	CSP
ndb_av_frac_y_cons	NAF
ndb_data_agg_runs	NDR
ndb_gsp_groups	NGG
ndb_gsp_groups_dis	NGD
ndb_gsp_groups_run	NGR
ndb_gspg_pc_av_eac	NGP
ndb_isr_agent_apps	NIA
ndb_llf_classes	NLC
ndb_m_participants	NMP
ndb_measure_reqs	NMR
ndb_profile_classes	NPC
ndb_settlements	NSE
ndb_std_sett_cfgs	NSS
ndb_threshold_pars	NTP
ndb_t_p_regimes	NTR
ndb_vsscpcs	NVS
ndb_check_dc_data_runs	NDC
ndb_instructions	NIS
ndb_instruction_status_reason	NIR

Table Name	Record Type
ndb_refresh_instr_failure	NRF
ndb_refr_instr_failure_reason	NRR
ndb_user_roles	NUR

9.3 Auditing of Data Aggregation Runs

The Aggregation Records are required for audit purposes on an occasional basis. For a number of settlement days during the year, the Pool Auditor will require access to all the data for the associated aggregation runs. To enable Auditors to check the data that is used in a Data Aggregation Run, the following functionality is provided with the NHHDA application software:

- updates to data used by an aggregation run are prevented until a backup of the NHHDA database has been performed;
- an audit log (Aggregation Run Log) can be generated to provide information on the data that was used in a Data Aggregation Run.

The following guidelines are provided to enable the Auditor to check the data generated by an Aggregation Run:

1. To ensure that data held in the backup reflects the state of the database *immediately* after a data aggregation run has finished, a backup of the database and flat files is performed as part of the aggregation process. At the start of the Data Aggregation process, a lock is set that prevents the following:
 - Instruction Processing;
 - Updates to Average Fractions of Yearly Consumption;
 - GSP Group - Profile Class Researched Default EAC;
 - Threshold Parameters.

This lock is reset manually once the backup has completed, by executing the following from the Bin directory:

```
nhh_unlock.exe
```

Alternatively, a script can be produced by the User organisation to automate the backup and unlock the database. An example script is provided, and is located in the \$RUNTIME/backup directory in the NHHDA filestore.

2. To enable the Auditor to repeat a Data Aggregation Run without deleting the original Aggregation Records, the backed up database and flat files must be restored to a *non-live* database.
3. An audit log, (the Aggregation Run Log), can optionally be generated during a Data Aggregation Run, enabling the Auditor to check the data used in and output by a Data Aggregation Run. The mechanism to enable or disable the creation of the log is via the 'NAR Audit Log Enabled' system parameter, which can be set using the Maintain System Parameters form, described in the NHHDA Operations Guide.

It is recommended that this logging is only enabled in a non-live environment to support the requirements of the Auditor, as the log is likely to be large. The Aggregation Run Log can be viewed using server operating system commands, and is of the following format:

Header - containing file creation details;

Aggregation Run Log Header - containing identifiers for the aggregation process;

Metering System Records - multiple records containing Metering System Ids;

Run Data Records - between 1 and 30 records, each one giving details of the data used in a particular aggregation run. The following data is recorded:

- Aggregation Run Number, internal to NHHDA;
- Id of Data Collector Id that supplied the aggregated data;
- Indexes for the Supplier Purchase Matrix group of cells into which the Meter's data was aggregated for: Line Loss Factor Class; Distributor Id; Supplier Id; Standard Settlement Configuration Id; Profile Class Id; GSP Group Id;
- Type of Consumption - A, E or D for AA, EAC or Default values aggregated.

Measurement Requirement Records - multiple records containing Time Pattern Regime information, and aggregated values.

These records may be viewed using a server Operating System editor such as vi.

4. The Data Aggregation is repeated in the non-live environment.
5. The Supplier Purchase Matrix generated from the repeat run can be compared with that from the original run, (the original can be re-generated using the Generate Supplier Purchase Matrix form - see section 24 of the NHHDA Operations Guide), to confirm that the same data has been used in the original and repeat run.

10 Starting Up and Shutting Down the System

This section describes the steps required to start up and shutdown the NHHDA system in a controlled manner. Where steps involve non-application specific functionality, you are referred to the appropriate documentation.

10.1 Starting the System

To start up the NHHDA system, (except between performing a backup and applying a Refresh Instruction, which is described in section 14), execute the following script from the Bin directory:

```
nhhda_start
```

This script starts up the Scheduler, File Receipt and Logging processes.

To check that the system has started correctly, use server operating system functionality to check that the following processes have started correctly:

- Logger (for Operator and Error logs);
- Scheduler;
- File Receipt;
- File Sender.

Note that these processes are owned by the 'batch' user that is set up during installation.

For example, if all processes started by `nhhda_start` have started successfully, running the unix `ps` command:

```
ps -u batch
```

displays the following type of information:

PID	TTY	S	TIME	CMD
378	??	S	0:03.95	./clgd O
380	??	S	0:04.06	./clgd E
382	??	S	0:16.47	./cscd -f
384	??	S	0:01.91	./cscd -f
386	??	S	0:01.03	./cfrd
388	??	S	0:02.20	./cfsd

where:

- `clgd O` is the logging of Operator Logs;
- `clgd E` is the logging of Error Logs;
- `cscd` is the Scheduler;
- `cfrd` is the File Receipt process;
- `cfsd` is the File Send process.

If any of these processes fail, the system should be stopped, as described in section 10.2, and after approximately one minute, re-started using `nhhda_start`.

10.2 Shutting Down the System

To shut down the NHHDA system in a controlled way, execute the following command from the Bin directory:

```
nhhda_stop
```

DRAFT

11 Monitoring the System

You can use the following to monitor the NHHDA system:

- Operator and Error Logs;
- Scheduler Logs;
- Audit Logs;
- Aggregation Exceptions Log;
- Aggregation Run Log;
- Data Collector Exceptions Log;
- Load MDD Exception Log
- Load Data Aggregation and Settlement Timetable File Exception Log;
- Directories;
- File Receipt and File Send Logs;
- EAC Data To Distributor Exception Logs.

11.1 Operator and Error Logs

These are human-readable files used to record events and errors. The files are written to via the Logging (CLG) subsystem. Many of the system warnings and messages to the operator are put in these logs. Each entry starts with a timestamp created by CLG followed by text that identifies the event or error. A new file is created for each log each day.

The log file names have the following format:

```
OPcurrent_date.LOG
```

```
ERcurrent_date.LOG
```

where `current_date` is the current system date, in the format YYYYMMDD. For example, an Operator Log for 1st June 1997 would be named `OP19970601.LOG`.

The files are allocated file types L0004001 and L0005001 respectively. The location of these files within the NHHDA local file store depends on the value of “`directory_id`” in the `cdb_default_directory` table. Refer to section 6.3 for further details about this table.

If you wish to make the operator and/or error logs available to client workstations, ensure that they appear in a directory of their own (`cdb_file_directory`, `cdb_default_directory`); create a read-only file service on the server (using whatever network products you have available); map a network drive on the client workstation on to the network drive. The logs will then be visible to the users using, for example, Wordpad. The operator and error logs are available through the client workstation via the Select Reports screen and are accessed in the same way as other reports.

These logs are archived at intervals defined by the “Op/error log period” system parameter. Refer to section 7 for further information about System Parameters and to section 12 for more details about archiving.

Messages included in Operator Logs are given in the NHHDA Operations Guide. Section 4.5.2 of the NHHDA Operations Guide also gives further information to assist users in monitoring batch processes and identifying the outcome of those processes. Messages that are included in Error Logs are given in Appendix A of this document. Those messages generated by underlying software such as Oracle that may be shown in the Error Logs, are outside the scope of this document.

11.2 Scheduler Logs

The output of all processes handled by the Scheduler is redirected to log files as well as the Operator and Error Logs. These additional log files can be used to monitor batch processes in the event of any failure that prohibits creation of the Operator and Error Logs. Messages recorded in the Scheduler Log provide the same level of information as the Operator Log. Further information about using the information recorded in the Operator Log is given in section 4.5.2 of the NHHDA Operations Guide. The Refresh Processing Log, described in section 14 of this guide, is a particular type of Scheduler Log, and provides information on the progress and outcome of a Refresh.

The Scheduler Logs are read-only files, created in the directory defined in the `cdb_system_parameter` table for the Log Directory system parameter. Scheduler logs have the following filename format:

`Annn_pid`

where `nnn` is the activity id and `pid` is the process id.

Note that a record of these log files is *not* held in the `cdb_file_reference` table.

If you wish to make the scheduler logs available to client workstations, ensure that they appear in a directory of their own (`cdb_file_directory`, `cdb_default_directory`); create a read-only file service on the server (using whatever network products you have available); map a network drive on the client workstation on to the network drive. The logs will then be visible to the users using, for example, Wordpad.

The Log Directory should be periodically cleared of old log files using Operating System tools. The frequency with which this task is performed will depend on the operational environment and operational policy.

11.3 Audit Logs

Audit data is initially written to the database tables `cdb_audit_n` and `cdb_audit_fields_n`. The value of ‘n’ runs from 1 to 7, such that a separate table is written each day of the week.

Each day a batch process is run which goes through the sets of tables that are not in use and writes out their contents to structured files (and deletes the corresponding database entries).

The audit log files produced are read-only files which can be searched using Operating System tools such as 'grep' and 'vi' to identify all changes made to the database. Refer to section 9 for further information about auditing.

11.4 Aggregation Exception Log File

The Aggregation Exception Log file is a flat file created during a Data Aggregation Run, and records exceptions found in the data used by the process. The file is created in a directory defined by `cdb_default_directory`. The log can also be displayed and printed using the Select Reports form via the NHHDA user interface. Refer to the NHHDA Operations Guide for further information.

11.5 Aggregation Run Log

The Aggregation Run Log is a flat file generated during a Data Aggregation Run if auditing is set on, using the 'NAR Audit Log Enabled' system parameter. Refer to section 7 for further information about system parameters. Refer to section 9.3 for details of the structure of the Aggregation Run Log.

If you wish to make the Aggregation Run Log available to client workstations, ensure that they appear in a directory of its own (`cdb_file_directory`, `cdb_default_directory`); create a read-only file service on the server (using whatever network products you have available); map a network drive on the client workstation on to the network drive. The log will then be visible to the users using, for example, Wordpad.

11.6 Data Collector Exception Log

The Data Collector Exception Log file is a flat file created during comparison of PRS Agent and Data Collector data, and records inconsistencies found in the data. The file is created in a directory defined by `cdb_default_directory`. The log can also be displayed and printed using the Select Reports form via the NHHDA user interface. Refer to the NHHDA Operations Guide for further information.

11.7 Load MDD Exception Log

The Load MDD Exception Log is a flat file created during loading of Market Domain Data if any errors are found in the data. The file is created in the directory defined by `cdb_default_directory`. The log can also be displayed and printed using the Select Reports form via the NHHDA user interface. Refer to the NHHDA Operations Guide for further information.

11.8 Load Data Aggregation and Settlement Timetable File Exceptions Log

The Load Data Aggregation and Settlement Timetable File Exception Log is a flat file created during loading of a Data Aggregation and Settlement Timetable File if any errors are encountered in the Timetable. The file is created in the directory defined by `cdb_default_directory`. The log can also be displayed and printed using the Select Reports form via the NHHDA user interface. Refer to the NHHDA Operations Guide for further information.

11.9 Directories

You can check the contents of the directories listed in section 6.1 using standard Operating System functionality. For further information on the

naming convention used for files contained in these directories, refer to section 6.2.

11.10 File Receipt and File Send Logs

The File Receipt and File Send logs record background processing of the File Receipt and File Send processes respectively. The filename format of the File Receipt and File Send logs is CFR_YYYYMMDD.log and CFS_YYYYMMDD.log respectively.

11.11 EAC Data To Distributor Exception Logs

The NDP process creates two types of files during a report run: P0222 report files and an L0053 exception log file. Following the successful completion of an NDP report an exception log file will always be generated, and it can be viewed from the Select Reports form; refer to the section on viewing reports in the NHHDA Operations Guide. The exception log will list each Distributor that requested a report and indicate if a report file was created, and it also lists any metering system exceptions encountered during retrieval of the metering system data.

DRAFT

12 Archiving

Archiving of data from the NHHDA system consists of two parts:

- saving the data on long term media;
- deleting the online copy of the data.

In determining the data to be deleted, two types of data must be considered:

- data stored in the Oracle database;
- data stored in operating system files.

Each can be considered separately. Firstly, for data in the Oracle database, a set of rules can be derived which will determine the interaction of the individual data items and therefore what can be deleted and what cannot even if it meets other (time based) criteria. For data stored in operating system files the consideration is simpler and is restricted to determining if the whole file can be deleted.

It should be noted that the archived data cannot be restored back into the live system. The data can only be restored into a copy of the live system for analysis purposes or for rerunning of various activities (eg Aggregation) at the point of archive.

Both files and database tables are allocated to Archive Groups, each of which has its own rules. Two database System Parameters are stored for each group:

- The ‘ARP’ parameter holds the Archive Period, which is the number of days which must pass before data in this Archive Group can be archived. This parameter is user maintainable via the Maintain System Parameters form – see section 7.
- The ‘ARD’ parameter holds the Last Archive Date, which is the date when this Archive Group was last successfully archived. This parameter is not user maintainable, so not listed in see section 7.

If the ‘ARP’ parameter is increased for an Archive Group, so that the Archive Period starts before the Last Archive Date, then archiving of that Archive Group will not be considered until the system date has ‘caught up’ to the change - unless the Archive Group is ‘FIN’ or ‘FIS’. ‘FIN’ and ‘FIS’ are special cases, discussed in section 12.3.

12.1 Archiving Operating System Files

Data stored in Operating System files is treated on a file by file basis, ie. an entire file is deleted in one go rather than individual data items within it.

The criteria used to select files for archiving is based on data held in the Oracle database about the files and their file types:

File Type	Archive Group	Archive Rule(s)
instruction file	FIN	Must have status of ‘PROCESSED’, ‘CORRUPTED’ or ‘SKIPPED’ To allow NHHDA to determine handling of the next file, do not delete the

File Type	Archive Group	Archive Rule(s)
		last 'processed' file from a data source. Note that the value of the Archive Period System Parameter ARP/FIN will be additionally used to determine the archive date for instruction data if it is greater than the value of ARP/FIS – see Section 12.2.
unknown/corrupt file	FUK	
supplier purchase matrix	FSP	
DC Performance file	FDC	
failed instruction report	FFI	
check data collector data exceptions	FCE	
audit log	FAU	
operator log	FOP	
error log	FER	
user generated reports	FUR	
exception reports	FEX	
incoming data files	FID	To allow for reprocessing, do not delete the last processed file of each data file type processed by NLD. Do not delete any unprocessed data files. Data files with status rejected may be deleted if they satisfy the other archiving criteria.
DC Summary Report	FCS	

Note: For Market Domain Data Complete Set and Data Aggregation and Settlement Timetable files, the latest file to have been loaded is retained on the system so that reprocessing of these files is possible.

Also the FUR archive group does not include the EAC Data to Distributor report (P0222).

A file will be archived if the last activity on the file, i.e.: greatest (CREATION_TIME, RECEIVED_TIME, PROCESS_SEND_TIME), is before the Archive Date (defined as today's date minus the archive period). The last activity value is a date-time whereas the Archive Date is a date only (implied time 00:00:00). So a file with a creation date-time of 1 Dec 1997 13:10 will not be archived when the Archive Date is 1 Dec 1997.

Two utilities (archive and arc_path) are supplied with the NHHDA application software to support archiving of data stored in the Oracle database and data stored in Operating System files. The steps to archive data are as follows:

12.1.1 Archive the Files to the Archive Directory

From the Operating System command line, run the `nhh_submit.exe` utility as follows:

```
nhh_submit.exe x
```

This performs the following (as well as archiving database data, as described in section 12.2):

1. For each Operating System file that meets the criteria defined in section 0, sets the status of the corresponding row in `cdb_file_reference` to “103” (Archived);
2. Moves these files to the directory that is specified in `cdb_default_directory` for files with a status of “Archived”. The actual path for this directory is defined in `cdb_file_directory`.
3. Each time files are archived, a different archive directory is used. The `cdb_default_directory` and `cdb_file_directory` tables are updated by the `archive` utility with the details of the archive directory for the next archive run. (This only takes place if steps 1 and 2 completed successfully.) Once this step has been performed, any files for which the status is subsequently changed to Archived (for example, manually) are moved to the ‘new’ archive directory and are not processed until the next archive run.
4. The Operator Log is updated to indicate that files have been archived and are ready to be copied to tape.

Note that the “Archived” files can still be seen via the Browse File Extraction and Transmission Statuses form on the user interface. However, if the system is set up so that the Oracle System Parameter for `utl_file_dir` is not set to ‘*’ then each new archive directory must be added to value of `utl_file_dir`, to view the files in this way.

The database holds two items of location information for directories - firstly the physical path on the server and secondly the archive media identity (initially this is blank).

Following archive, the operator has to:

- copy files from the archive directory onto archive media
- tell the system the identity of the archive media
- tell the system that the files are now off-line
- delete the files from the archive directory.

12.1.2 Copy Files to Archive Media

The Operator can now copy the files from the archive directory to off-line media using Operating System tools. This can be performed at a time that is convenient to the Operator.

12.1.3 Record the Archive Media of the Files

In order that the location of archived files can be recorded in the database, the `arc_path` utility can be run from the Operating System command line as follows:

```
arc_path -m media
         [-u <username>]
         [-p <password>]
         -f archive_directory
         -t archive_media
```

where:

- `archive_directory` is the archive directory (this is the full path name of the directory)
- `archive_media` uniquely identifies the archive set (eg: tape label)

The database is updated to record which archive media contains copies of the files. At this stage, the file details can still be seen via the Browse File Extraction and Transmission Statuses form as the files are still online. See the NHHDA Operations Guide for further details.

12.1.4 Record the removal of the files from Archive Directory

Before removing the files from the archive directory, the Operator should notify the system that the files are off-line, using the `arc_path` utility, as follows:

```
arc_path -m offline
         [-u <username>]
         [-p <password>]
         -t archive_media
```

where

- `archive_media` is the archive identifier as above

The database is updated to indicate that the files are no longer available on the server. The Operator can now delete the files from the archive directory using Operating System tools. Deletion of the files can be performed at any time after the system has been told that the files are now offline at a time that is convenient to the Operator.

If the files have been archived onto a WORM (Write Once Read Many) disk, the disk can be removed from the drive or jukebox.

If the files are deleted *before* telling the system that they are now offline, the system may attempt to access the files causing it to report errors.

The two commands above may be combined:

```
arc_path -m media -m offline
         [-u <username>]
         [-p <password>]
         -f archive_directory
         -t archive_media
```

12.2 Archiving Database Data

Archiving of data from the NHHDA database uses a set of criteria, some of which are time-based, some of which are based on business rules.

The archive process consists of two stages:

- backing up of database onto off-line media;
- deletion of database data that meets time-based and rule-based criteria given in section 12.2.1.

12.2.1 Database Archive Criteria

The criteria for archiving data from the NHHDA database can be categorised as follows:

- **Time-based** - each Archive Group is assigned an Archive Period. When an archive of the database is performed, the creation time on each record is checked (against the system date minus Archive Period) to establish if the record is “old enough” to be archived;
- **Rule-based** - rules about the data contained in Archive Groups *supplement* the time-based criteria. When an archive of the database is performed, each record of each table is checked against any rules that are applicable to that table’s Archive Group, to establish if the record can be archived.

The following table shows the time-based and rule-based criteria that is used to select database records for archiving. The columns of the tables are as follows

- The Table column gives the name of the database table.
- The Date Column(s) column indicates the column in the database table to which the time-based criteria is applied.
- The Controlling Archive Period shows the parameter (param_type2) that is responsible for establishing the archive date for the specified table.
- The Deletion Rules column shows the rule-based criteria applied to the table. In this column, “ARCHIVE_DATE” is system date less archive period.

For example, for the `ndb_ms_prs_dets` table, a record is archived if:

- the date equal to the system date less the days in the archive period (ARCHIVE_DATE) is later than `eff_to_sett_date`;
- the record is not the latest record prior to ARCHIVE_DATE for this metering system.

Table	Date Column(s)	Controlling Archive Period (Param)	Deletion Rule(s)
NDB_MS_PRS_DETS	EFF_TO_SETT_DATE	DBS	ARCHIVE_DATE >= EFF_TO_SETT_DATE.
NDB_MS_DC_DETS	EFF_TO_SETT_DATE	DBS	ARCHIVE_DATE >= EFF_TO_SETT_DATE.
NDB_DATA_AGG_APPS	EFF_TO_SETT_DATE	DBS	ARCHIVE_DATE >= EFF_TO_SETT_DATE.

Table	Date Column(s)	Controlling Archive Period (Param)	Deletion Rule(s)
			if removing last record for this metering system then additionally remove all records from NDB_MS_PRS_DETS, NDB_REGISTRATIONS and NDB_DC_APPS for this metering system.
NDB_REGISTRATIONS	EFF_TO_SETT_DATE	DBS	ARCHIVE_DATE >= EFF_TO_SETT_DATE additionally, delete all records from NDB_DC_APPS for any deleted registration
NDB_MS_EXCEPTIONS	EFF_TO_SETT_DATE	DBS	ARCHIVE_DATE >= EFF_TO_SETT_DATE.
NDB_INSTRUCTIONS, NDB_INSTRUCTIONS-STATUS_REASON	LATEST OF FILE_ID.DATE FIELDS	FIS	ARCHIVE_DATE >= MAX (CREATION_TIME, RECEIVED_TIME, PROCESS_SEND_TIME) AND the instruction file is archived (the status flag in cdb_file_reference is used to determine whether the files have been archived). Instruction files will have been archived according to the value of FIN days (see Section 12.1) before archiving instruction data Note that the value of FIN days will be used to determine the archive date if it is greater than the value of FIS days as instruction data cannot be archived before the corresponding instruction files are archived.
NDB_REGISTER_CONS (Annualised Advances)	EFF_TO_SETT_DATE	DBS	ARCHIVE_DATE >= EFF_TO_SETT_DATE.
NDB_REGISTER_CONS (Estimated Annual Consumption)	EFF_FROM_SETT_DATE	DBS	ARCHIVE_DATE >= EFF_FROM_SETT_DATE and <i>either</i> there is a later EAC record with ARCHIVE_DATE >= EFF_FROM_SETT_DATE from an appointed Data

Table	Date Column(s)	Controlling Archive Period (Param)	Deletion Rule(s)
			Collector or there are no NDB_DATA_AGG_APPS for the metering system with EFF_TO_SETT_DATE >= this record's EFF_FROM_SETT_DATE
			If deleting a record from NDB_REGISTER_CONS leaves a metering system with no record in NDB_REGISTER_CONS from the same data collector, all records in NDB_MS_DC_DETS for that metering system from the same data collector are also deleted
NDB_SETTLEMENTS NDB_DATA_AGG_RUNS NDB_SPMATRIX	SETTLEMENT_DATE	DBS	ARCHIVE_DATE >= SETTLEMENT_DATE also delete all child records in NDB_DATA_AGG_RUNS, NDB_GSP_GROUPS_RUN, NDB_SPMATRIX
NDB_ISR_AGENT_APPS	EFF_TO_DATE	DBS	ARCHIVE_DATE >= EFF_TO_DATE
NDB_GSP_GROUPS_DIS	EFF_TO_SETT_DATE	DBS	ARCHIVE_DATE >= EFF_TO_SETT_DATE
NDB_AV_FRAC_Y_CONS	EFF_TO_SETT_DATE	DBS	ARCHIVE_DATE >= EFF_TO_SETT_DATE
NDB_THRESHOLD_PARS	EFF_FROM_SETT_DATE	DBS	ARCHIVE_DATE >= EFF_FROM_SETT_DATE and this is not the latest record prior to or on the ARCHIVE_DATE.
NDB_GSPG_PC_AV_EAC	EFF_TO_SETT_DATE	DBS	ARCHIVE_DATE >= EFF_TO_SETT_DATE
CDB_ACTIVITY	SCHEDULE_TIME	DBA	ARCHIVE_DATE >= SCHEDULE_TIME also delete any child records in CDB_ACTIVITY_PARAMET ER
CDB_FILE_REFERENCE, CDB_DATA_FILE, CDB_FILE_EXPORT, CDB_REPORT_FILE, CDB_INSTRUCTION_FILE	greatest (CREATION_TIME, RECEIVED_TIME, PROCESS_SEND_TIME) on CDB_FILE_REFERENCE table	DBF	Records in CDB_FILE_REFERENCE, CDB_DATA_FILE, CDB_FILE_EXPORT, CDB_REPORT_FILE, CDB_INSTRUCTION_FILE are not deleted before the corresponding file has been archived and taken

Table	Date Column(s)	Controlling Archive Period (Param)	Deletion Rule(s)
			off line. For instruction files, child records in NDB_INSTRUCTIONS and NDB_INSTRUCTION_STATUSES_REASON are also deleted
NDB_METERING_SYS			If there are no details in NDB_MS_PRS_DETS, NDB_MS_DC_DETS, NDB_REGISTRATIONS, NDB_REGISTER_CONS or NDB_INSTRUCTIONS then delete NDB_METERING_SYS and any child records in NDB_MS_EXCEPTIONS.
NDB_EXCEPTION_DATA	FILE_CREATION_DATE		ARCHIVE_DATE >= FILE_CREATION_DATE

12.2.2 Back Up Database Data

Prior to deletion of data to be archived, a successful backup of the database must be performed using server Operating System functionality.

This backup can be performed as part of the overnight batch processing, immediately after data aggregations, and prior to deletion of data to be archived. Note that if this backup is restored to a non-live database, the data and log of any files processed, eg. created, received, after the backup will be lost.

Refer to section 13 for further information about backup.

12.2.3 Archive Database Data

Once a backup of the NHHDA database has been performed, data that meets the time-based and rule-based criteria can be deleted from the database using the `nhh_submit.exe` command, from the server Operating System command line.

To delete the data from the database immediately, enter the following command:

```
nhh_submit.exe x
```

Additional parameters, to perform this operation at a particular time are described in the Scheduling Batch Jobs section of the NHHDA Operations Guide.

12.3 Archiving of Instruction Data – Archive Groups ‘FIN’ and ‘FIS’

Instruction Data (Archive Groups FIS and FIN) form a special case. The archive routine will always consider these groups for archiving, regardless of the Last Archive Date. This is because Instruction Data (‘FIS’) cannot be deleted until the corresponding Instruction File (‘FIN’) has been archived,

and Instruction Files become available for archiving according to rules which are not purely time-based; it could be several years before an Instruction File can be archived. When archiving runs, any number of old Instruction Files may have become available for archiving for the first time. Specifying an Archive Period prior to the Last Archive Date is a useful technique enabling the number of Instruction Files to be archived to be controlled.

12.4 Restoring Operating System Files

Operating System files can be restored using Operating System Tools.

If the files have been archived onto a WORM (Write Once Read Many) disk, the disk can be reinserted into the drive or jukebox.

The system is informed of the location of the files using the following command:

```
arc_path -m online
        [-u <username>]
        [-p <password>]
        -f archive_directory
        -t archive_media
```

where

- archive_media is the archive identifier as above
- archive_directory is the directory where all the files which were copied to the archive media have been restored (this is the full path name of the directory)

The database is updated to indicate where the files are now located. The files will again be recognised by the system.

Once the files have been finished with, the procedure described above (Remove the Archived Files from Archive Directory) should be followed.

The following example shows the changes made to the database by the above steps.

Directory Id	Path	Media
9876ArchiveN	- (none)
12.1.3	<i>Record the Archive Media of the Files</i> <i>arc_path -m media</i>	
9876ArchiveN	Tape XYZ
12.1.4	<i>Record the removal of the files from Archive Directory</i> <i>arc_path -m offline</i>	
9876	- (none)	Tape XYZ
12.3		

12.5 Archiving of Instruction Data – Archive Groups ‘FIN’ and ‘FIS’

Directory Id	Path	Media
	<p>Instruction Data (Archive Groups FIS and FIN) form a special case. The archive routine will always consider these groups for archiving, regardless of the Last Archive Date. This is because Instruction Data ('FIS') cannot be deleted until the corresponding Instruction File ('FIN') has been archived, and Instruction Files become available for archiving according to rules which are not purely time-based; it could be several years before an Instruction File can be archived. When archiving runs, any number of old Instruction Files may have become available for archiving for</p>	

DRAFT

Directory Id	Path	Media
	the first time. Specifying an Archive Period prior to the Last Archive Date is a useful technique enabling the number of Instruction Files to be archived to be controlled.	

Restoring Operating System Files

arc_path -m online

9876	...RestoreDirectory	Tape XYZ
------	---------------------	----------

12.1.4

Record the removal of the files from Archive Directory

arc_path -m offline

9876	- (none)	Tape XYZ
------	----------	----------

Once restored into the appropriate directory, the files can be viewed via the user interface. Note that these files have a status of “Archived” in the Browse File Extraction and Transmission Statuses form.

Note that if the files are restored to a different machine, the database on that different machine should have originally been associated with those files and should be more recent than the files; in this way, details of the files will have already been recorded in the database.

12.6 Restoring Database Data

Archived Oracle data, ie. the data backed up to tape prior to deletion from the database, (as in section 12.2.2), can be restored to a database that is separate from the live system database. This can be achieved using server Operating System commands. Note that details of any files processed since the backup will be lost.

To view the data held in restored database tables, you can use the NHHDA User Interface.

13 Backup and Recovery

The principal mechanisms for backup and recovery are those provided by the Oracle database and the Operating System. The NHHDA system will be protected against hardware failures and corruption by the use of standard system backup and recovery mechanisms.

It is the responsibility of the User organisation to develop a policy for backup of the NHHDA database and file store. This section provides guidelines on aspects of such a policy, and discusses the NHHDA application software functionality that supports backup and recovery.

13.1 Guidelines on Backup Policy

The main purpose of a backup policy should be to ensure that sufficient data is held off-line to enable recovery of the system in the event of failure. Additionally, backups should be available for restoration of a secondary database to support the requirements of the NHHDA Auditor.

A backup must also be performed prior to deletion of archived data, (refer to section 12.2 for further details).

A backup policy should ensure that a copy of the database and all external input and output files on the system are written to backup media on a planned basis, following key operational activity, eg. after performing an aggregation run.

A suggested backup procedure is to perform a full backup of the NHHDA database, and either a full or incremental backup of the file store on a daily basis, and should include:

- all database files;
- files stored in the NHHDA file store
- database control files;
- database redo logs.

13.2 Checkpointing

The Oracle database should run in ARCHIVELOG mode. This means that “redo” logs, containing information relating to changes in the database, are automatically copied to an archive area on the disk, enabling recovery of the database. It is assumed that the archive area for holding the redo logs, and the Oracle database tables is on separate media, to ensure that after any single media failure, the database can be recovered using a combination of backups, redo logs and the database itself. Furthermore, if a redo log is lost due to media failure, the database is exposed to any further media failure until the next backup. It may therefore be advisable that the redo logs are duplicated, either using RAID mirroring or Oracle Redo log mirroring.

13.3 Daily Off-line Backups of the NHHDA Database

Off-line backups performed during overnight processing should enable the User organisation to:

- recover the NHHDA system following failure;

- support the requirements of the NHHDA Auditor;
- support the needs of the User organisation to archive data from the database.

Results of Data Aggregation runs are required on an occasional basis by the Auditor. To ensure that the Auditor has access to exactly the same set of data that was used in a Data Aggregation Run, an off-line backup of the database is performed *immediately* after Data Aggregation Runs have been performed during end of day processing. To ensure that the database is not updated by any other processes before the backup is performed, a database lock is set, preventing changes to the database by processes other than the aggregation process. This lock prevents the following:

- Instruction Processing;
- Updates to Average Fractions of Yearly Consumption;
- Updates to GSP Group - Profile Class Researched Default EACs;
- Updates to Threshold Parameters.

Once the backup has completed, the `nhh_unlock.exe` utility, which is run from the command line, enables the operator to release the database lock.

This backup of the NHHDA database can also be used to restore the database in the event of failure.

The daily backup is also the mechanism of storing data off-line prior to deletion of appropriate data from the database using archiving functionality. A successful backup of the NHHDA database must be performed immediately before archiving data from the database using application software functionality. Refer to section 12 for further information on archiving.

A script may be developed by the User organisation to perform the backup and unlock the database. An example script is provided in the `$RUNTIME/backup` directory of the NHHDA filestore.

13.4 Daily Backups of the NHHDA File Store

In addition to the NHHDA database, files stored in the NHHDA file store should also be backed up daily. A daily incremental backup of the file store may be performed, with an additional full backup periodically. This task is performed using the functionality provided by the Operating System.

A script may be developed by the User organisation to perform the backup. An example script is provided in the `$RUNTIME/backup` directory of the NHHDA filestore.

13.5 Backup Prior to Refresh of the Database

Occasionally, a PRS Agent may send Refresh instructions to the NHHDA system, to resolve inconsistencies between data held by NHHDA and that held by the Agent. Refresh of Instructions is performed via the NHHDA user interface. Refer to section 14 for further information.

A Refresh Instruction may update data for a large number of Metering Systems. Each Metering System is processed as a success unit (ie Processing is performed for one Metering System at a time). In the event of a failure of the refresh, the database will be in an indeterminate state as the refresh will only have been applied to a subset of the metering systems. If the refresh is re-attempted, the process re-checks the data in the Instruction against the data in the database for all metering systems, whether or not they have been successfully applied. If it is not possible to re-attempt the refresh immediately, eg. because of insufficient time, the database must be restored to its state prior to the failed refresh. To support this, a backup of the database must be taken before the refresh is requested by the User, (the User is given a warning to this effect when requesting the refresh).

Note that after the restore, the database will indicate that the refresh has not been applied - in this case, the user needs to discard the refresh, to enable subsequent Instructions to be processed.

For further information about managing a PRS Refresh, refer to section 14.

13.6 Restoration for Recovery

This section outlines the functionality provided by the NHHDA application software that supports recovery of the system in the event of failure.

13.6.1 Recovery from Power Failure

This section outlines recovery after any interruption that causes all active processes to be terminated. For example, as a result of power supply failure or failure of system component.

When the cause of the failure has been identified and rectified and the system is restarted, the Oracle database automatically recovers to the last committed transaction. Any user initiated transactions that had not been committed when the failure occurred are rolled back.

Any file transmissions that were in the progress are repeated. In the case of files being sent, the resend will be carried out automatically by the File Sender (CFS) daemon. For incoming files, the resend will need to be initiated from the Gateway. This will be either by manual request, or through the Gateway detecting that the original transmission did not complete.

13.6.2 Recovery from Fatal Errors

This section outlines recovery after failure to an individual process caused by failure of a hardware component or due to a fatal error during processing. The database is recovered to the state prior to failure, excluding any transactions that were in progress at the time of the failure. Any files that were open are closed.

If one of the batch jobs is interrupted, the job is automatically rescheduled by the Scheduler process.

13.6.3 Recovery from Media (disk) Failure

This section gives an overview of system recovery following a failure of one of the system's disks.

If the failed disk is one of a pair of disks, for example in the use of RAID1, then the system continues functioning normally as the second disk is brought into operation.

If the failed disk is not paired, or if both disks in a pair fail, the possible implications are as follows:

Failure of Database Disks

The database tables affected by the failure can be recovered from backups and redo logs.

Failure of Redo Log Disks

Loss of the redo log disks does not immediately impact the integrity of the system. However, a backup of the database at the earliest opportunity is recommended, to minimise losses resulting from further failures.

File areas

The effect of loss of these depends on the processing state of the files lost. In most cases this can be determined from the files log (cdb_file_reference, etc) held in the database (which is assumed to be on separate media). However, the most recently arrived files will not yet have been recorded. Thus it may be necessary to check with the Gateway which files have recently been sent.

A range of possible states are considered below:

- In transmission inwards - assume send will be repeated automatically by the Gateway at a later time.
- Received but not processed - file will need to be manually requested for resend from the Gateway or original source. Processing will then be initiated normally.
- Processed but not yet backed up - file only required for audit. If an audit copy is required it can be requested manually from the Gateway or original source.
- Created and not backed up or sent - processing will need to be (manually) repeated to generate file. In some cases (eg: audit logs) this recreation may be difficult. Such files are candidates for holding on mirrored media to reduce the risk of loss.
- Backed up - lost files can be restored from backup.
- Sent and not backed up - file is only required for audit. If an audit copy is required it can be requested manually from the Gateway or target system to which it was sent (or processing can be repeated to generate a copy).
- In transmission - the database will not have recorded the transmission completion, therefore when the file is placed back in the send directory (either from backup or by repeat processing) it will be duly sent.

Where a file is permanently lost (ie. cannot be recovered from another source), it may be useful to update (manually) the database file reference

table (cdb_file_reference) to show this file's status as "deleted". Thus restoring consistency between the database and file store.

13.6.4 Recovery from Activity Status Tracking Problems

The Common Scheduler (CSC) subsystem records the statuses of activities (e.g., aggregation, CDCD runs and instruction processing) in the cdb_activity database table. Possible activity statuses include 'W' (waiting), 'S' (successful) and 'F' (failed). A status of 'U' (unknown) is provided for processes whose final state is unknown. This is used where the CSC daemon process has terminated (because of a system power failure, for example) before all activities have finished. In this case, when the CSC daemon is restarted, there may be a number of processes with status 'R' (running) that have probably terminated (successfully or otherwise) or may even still be running. These processes' statuses will be updated to 'U', clearing the queues of 'in progress' activities.

Activities marked as being in status 'U' will need to be manually checked and set to one of the valid exit statuses (see table below) before the CSC daemon will start any new processes. A status of 'A' (acknowledged) is provided for cases where a specific end-state cannot be identified but manual checking has confirmed that CSC can proceed. Alternatively, CSC can be forced to start whilst jobs are still in the unknown state by specifying a "forced start" argument when starting the CSC daemon.

The activity statuses of processes are viewable through the client via the Activity Monitoring forms. Refer to the Operations Guide, sections 34 & 35 for details of their operation.

Status	Description
S	Completed successfully
F	Completed unsuccessfully
K	Killed
A	Acknowledged (Actual exit status unknown)

13.6.5 Disaster Recovery

The Disaster Recovery procedures need to be developed in line with the local policies and procedures. A consideration will be whether recovery would require the use of an alternative machine or alternative site. Recovery is started from the latest backups available.

13.6.6 Recovery of temporary tables

This section describes the clearing down of system table(s) in the event of database connectivity problems during instruction processing.

Counts are maintained in the table `cdb_return_parameter` for use in the instruction processing. Successful completion of the instructions process normally results in the removal of all rows from the table. In the case where database connectivity or availability problems have been encountered and even when the database problem has been rectified the row(s) will persist. In the unlikely event that a large number of successive database problems occur during instruction processing, the table may contain numerous redundant data rows.

In this instance the DBAs must check the table `cdb_return_parameter` and manually truncate the table to remove all rows. To avoid conflicting with users, this should be completed before starting the NHHDA system.

13.7 Restoration for Auditing

The Auditor may restore the backup to a non-live database and re-run the Aggregation Run without deleting the Aggregation Records. These records may then be viewed using standard Operating System tools. On re-run, the Supplier Purchase Matrix generated can be compared with that from the original run to confirm the same data has been used.

14 PRS Refresh

A PRS Refresh is initiated from the Manage Refresh Instructions form of the NHHDA application software, as described in section 28 of the NHHDA Operations Guide. When the user selects the Apply button from the Manage Refresh Instructions form, a message is displayed prompting the user to ensure that a backup has been performed before continuing with the Refresh.

Section 14.1 describes the tasks to be performed by the System Manager prior to application of the Refresh Instruction; this includes backing up the NHHDA database and file store, and starting up some of the NHHDA processes.

Section 14.2 provides details of the information contained in the Operator and Error logs, and describes the content of the Refresh Processing Logs.

Section 14.2.6 gives guidance on the tasks to be performed by the System Manager prior to restarting the NHHDA application software following successful completion or failure of a Refresh.

14.1 Pre-requisites to the Application of a Refresh Instruction

It is important that the backup is performed *after* the Refresh Instruction File has been loaded by the NHHDA software, ie. is visible via the Manage Refresh Instructions form. The reason for this is that if the Refresh does not complete successfully, the database must be restored to its state prior to the Refresh. By performing the backup after the Refresh Instruction File has been loaded, the file will not be lost if a restore has to be performed.

If the database and NHHDA application software are running, they must both be shut down prior to performing the backup, as follows:

- Stop the NHHDA application software, using the `nhhda_stop` command, (refer to section 10 for further information);
- Shut down the Oracle database.

A full backup of the NHHDA Oracle database must then be performed.

Once the backup has completed, the Oracle database can be restarted.

Note that once the appropriate data has been backed up, the File Receipt process and File Send process **MUST NOT** be started up, because this may result in incoming or outgoing files being processed, resulting in the NHHDA database being in a different state to the backup.

In order that the user can initiate the Refresh from the Manage Refresh Instructions form, the Logger process and Scheduler process need to be started from the operating system command line, using the following command:

```
nhhda_start -r
```

This starts up the logger for logging messages to the Operator and Error Logs, and the Scheduler.

To check that these processes have started up, use the operating system `ps` command, (refer to section 10 for further information).

Once these processes have started, the Refresh can be initiated from the Manage Refresh Instructions form.

14.2 Logs Containing Information Relating to the Refresh Process

The messages logged in Operator, Error and Refresh Processing Logs form an audit trail of Refresh processing.

If the Refresh completes successfully, the following message appears in the Operator Log:

“Refresh Successful”.

If the Refresh fails, the following message appears in the Operator Log:

“Refresh failed”.

If the Refresh completes successfully but one or more Metering Systems have not been updated due to validation errors, the following message appears in the Operator Log:

“Refresh completed with validation errors”.

In addition to the Operator and Error Logs, one or more Refresh Processing Logs are created by the Scheduler in the directory in which the Scheduler logs are generated. The Refresh Processing Logs contain copies of all messages contained in the Operator and Error Logs, as well as a record of the changes made to the NHHDA database and any reasons encountered that prevent a Metering System from being updated. A Refresh Processing Log is created for each partition when the Refresh is applied from the Manage Refresh Instructions form.

The Log contains all records deleted and inserted, and both the before (old) and after (new) versions of records that are changed by the Refresh Instruction. The formats of the various reported changes are shown below:

To dates are blank for open-ended dates, (although they are stored on the database as 31 Dec 4712).

The Refresh Instruction Failures are viewable and maintainable through the client via the Manage/Report Refresh Instruction Failures and forms. Refer to the Operations Guide, sections 29 & 32 for details of their operation.

14.2.1 Changes made to `ndb_registrations` table

Type	Metering Sys	Eff.From	Eff. To	Supplier
NREG OLD	1234567890123	YYYYMMDD	YYYYMMDD	XXXX
NREG NEW	1234567890123	YYYYMMDD	YYYYMMDD	XXXX
NREG DELETE	1234567890123	YYYYMMDD	YYYYMMDD	XXXX
NREG INSERT	1234567890123	YYYYMMDD	YYYYMMDD	XXXX

14.2.2 Changes made to `ndb_data_agg_apps`

Type	Metering Sys	Eff.From	Eff. To	Sup.From
NDAA OLD	1234567890123	YYYYMMDD	YYYYMMDD	YYYYMMDD
NDAA NEW	1234567890123	YYYYMMDD	YYYYMMDD	YYYYMMDD
NDAA DELETE	1234567890123	YYYYMMDD	YYYYMMDD	YYYYMMDD
NDAA INSERT	1234567890123	YYYYMMDD	YYYYMMDD	YYYYMMDD

14.2.3 Changes made to `ndb_ms_prs_dets`

Type	Metering Sys	Eff.From	ES	GSP	MC	PC	LLF	Dis.	SSC	ES GG MC PC LF SC
NMPD OLD	1234567890123	YYYYMMDD	X	XX	X	XXXX	XXXX	XXXX	XXXX	Y Y Y Y Y Y

```

NMPD NEW 1234567890123 YYYMMDD X XX X XXXX XXXX XXXX XXXX Y| Y| Y| Y| Y| Y
NMPD DELETE 1234567890123 YYYMMDD X XX X XXXX XXXX XXXX XXXX Y| Y| Y| Y| Y| Y
NMPD INSERT 1234567890123 YYYMMDD X XX X XXXX XXXX XXXX XXXX Y| Y| Y| Y| Y| Y
    
```

Note that the change flags are either Y or blank - Y indicates that the value changes on the Effective From Settlement Date of the record, blank indicates that it does not change. The flags are as follows:

- ES 'Y' if Energisation Status is effective from the corresponding Effective From Settlement Date, otherwise null
- GG 'Y' if GSP Group Id is effective from the corresponding Effective From Settlement Date, otherwise null.
- MC 'Y' if Measurement Class Id is effective from the corresponding Effective From Settlement Date, otherwise null.
- PC 'Y' if Profile Class Id is effective from the corresponding Effective From Settlement Date, otherwise null.
- LF 'Y' if Line Loss Factor Class Id is effective from the corresponding Effective From Settlement Date, otherwise null.
- SC 'Y' if Standard Settlement Configuration Id is effective from the corresponding Effective From Settlement Date, otherwise null.

14.2.4 Changes to ndb_dc_apps

```

Type Metering Sys Eff.From Sup.From Participant
NDCA OLD 1234567890123 YYYMMDD YYYMMDD XXXX
NDCA NEW 1234567890123 YYYMMDD YYYMMDD XXXX
NDCA DELETE 1234567890123 YYYMMDD YYYMMDD XXXX
NDCA INSERT 1234567890123 YYYMMDD YYYMMDD XXXX
    
```

14.2.5 Instruction Failure Reasons

```

Reason Metering Sys Additional Data
Nxx 1234567890123 nnnnnnnn
    
```

xx is a reason code from the INSR domain; the additional data is as shown in section B.9 of the NHHDA Operations Guide.

Processing continues after an error unless that error is a physical file error, (OI - Invalid Instruction), in which case processing stops immediately.

If a Data Aggregator Appointment exists on the database with an Effective From Settlement Date before the significant date of the Instruction, and an Effective To Settlement Date on or after the significant date, the Refresh processing moves the Effective To Settlement Date to one day earlier than the significant date. The following Instruction Failure Reason is shown in the Refresh Processing Log, but is only a warning, and no action need be taken:

NZA <metering system id> <start date>

14.2.6 Summary Report

At the end of the log file for each partition for which processing successfully completes, a summary report appears:

```

Refresh thread: partition 2
12345 metering systems in file
12345 (100.00%) failed validation
789 metering systems on database not in file
    
```

0 (0.00%) not deleted due to validation rules

Complete - Successful

The report indicates how many Metering Systems appear in the Instruction for the current partition and how many of those were not updated due to failing validation checks. It also shows the number of Metering Systems on the database in the current partition for the distribution business which did not appear in the Instruction and how many of those could not be updated due to validation rules.

At the end of the log file for the refresh control process, a summary table appears containing the numbers reported for each partition plus the total for the whole Instruction:

Partition	Metering Systems	Failed Validation	Not in file	Not deleted
1	0	0	1	0
2	12345	12345	789	0
3	2	0	1	0
TOTAL	12347	12345	789	0

Refresh completed with validation errors

The summary totals for each partition, plus the overall total, are logged on the database in `ndb_instruction_status_reason` and so will appear in an Instruction report which contains this instruction.

14.3 Action to take after the Refresh completed

After the Refresh processing completes, the Refresh Instruction will be in one of three states. The action required varies according to the state:

14.3.1 Refresh status is "Applied"

The Refresh has been applied completely with no problems. No action is required to complete the Refresh process.

14.3.2 Refresh status is "Validation Errors"

The Refresh has been partially applied because one or more of the Metering Systems caused validation errors. The summary report (which is included in the Manage Refresh form) indicates how many problems were encountered. Either the problems must be acknowledged by accepting the Refresh ("Accept" button on the Manage Refresh form) - this updates the Refresh status to "Applied" - or the Refresh must be regarded as having failed and treated as described in 14.3.3 below.

The Refresh Instruction Failures are viewable and maintainable through the client via the Manage/Report Refresh Instruction Failures and forms. These forms allow the individual validation errors for a given Refresh instruction to be maintained and sent back to the PRS Agent if necessary. Refer to the Operations Guide, sections 29 & 32 for details of their operation.

14.3.3 Refresh status is "Discarded"

The refresh has failed, leaving the database in an indeterminate state. If the problems encountered can be resolved then resolve them and, using the Manage Refresh form, apply the Instruction again. If the problems cannot

be resolved, or there is insufficient time to reattempt the processing, the database must be restored to the state it was in immediately before the first attempt to apply the refresh.

The Refresh Instruction Failures are viewable and maintainable through the client via the Manage/Report Refresh Instruction Failures and forms. These forms allow the individual validation errors for a given Refresh instruction to be maintained and sent back to the PRS Agent if necessary. Refer to the Operations Guide, sections 29 & 32 for details of their operation.

14.4 Manage Refresh Instruction Failure

This form allows for the selection of PRS Refresh Instructions with validation failures for return to their source, along with their reasons for failure.

When a Refresh Instruction Failure is selected, the system presents a list of the Refresh Instruction Failure Reasons for that instruction. In this way, the individual reason codes can be sent back to the PRS Agent that owns the metering system, similar to the processing of non-refresh instructions where each instruction is considered separately.

DRAFT

14.5 Restarting the NHHDA Application Software After Refresh

After the Refresh has completed, the NHHDA processes already running (Loggers and Scheduler) must be stopped, using the `nhhda_stop` command.

If the Refresh was successful (ie is now has status "Applied"), all processes (Loggers, Scheduler, File Receipt, File Send), must be restarted using the `nhhda_start` command, (without the `-r` parameter).

If however, the Refresh fails, then any evidence of the cause of failure of the Refresh, eg. Refresh Processing Log, should be copied to an alternative location so it is not overwritten. The messages logged in the Operator, Error and Refresh Processing Logs form an audit trail of the PRS Refresh. The backup taken prior to the Refresh MUST then be restored before the system can be fully restarted. The logs can subsequently be analysed to determine the cause of the Refresh failure. Once the data has been restored, the NHHDA processes (Loggers, Scheduler, File Receipt, File Send), are restarted using the `nhhda_start` command. The Refresh Instruction will have been restored with a status of "Unprocessed" and so must be manually discarded using the Manage Refresh form.

DRAFT

15 System Management of Application Server

15.1 Remove the Old Report Files

In order to avoid space bottleneck on the Application server, the Old Report files needs to be deleted from the Reports directory at a regular interval.

Note:- Report files should always be deleted in the event of a database import or restore occurring on the database server. This is to prevent later produced report files having the same file name as any reports produced prior to the import/restore. Where such a conflict occurs, only the earlier reports would be visible to the user, which may not contain the expected data.

DRAFT

Appendix A Application Error Messages

The messages contained in this appendix can be reported in the NHHDA error logs. The messages are grouped under the process in which they could occur. Each message states why the operation or process has not proceeded normally. The cause of the exception and the remedial action required should be self-explanatory in the context of the operation or process that produces the exception. Further help in diagnosing messages can be sought from the Support Desk.

Messages displayed in the error logs are preceded by a timestamp in the following format:

```
DD-MON-YYYY HH:MM:SS
```

Text in the following format which precedes some messages can be used to identify the source of a message. This additional text may be used to report errors to a support desk, in accordance with procedures to be defined by the user organisation.

```
Error in <module name>, line <number>
```

Note that error messages which can be reported in the error log that are not application-specific are not shown in the following lists.

A.1 Error Log Messages

In the following message descriptions, the “%” symbol is used to indicate that the text at that point is inserted when the message is generated (to give more information about the cause of the condition being reported). “%d” indicates that an integer is inserted (eg Aggregation Run Number), while %s indicates that text will be inserted (eg a filename). (See a definition of the printf C function for a complete list on the meaning of the characters after the “%” symbol.)

A.1.1 Data Aggregation

Aggr Run %d has invalid Status %s to perform Generate Output

An error occurred in opening DC PERF file (L0043001) for run %d

An error occurred in writing header details in DC PERF file (L0043001) for run %d

An error occurred writing DC PERF file (L0043001) for run %d

Cannot determine data agg run details for agg run no %d

Cannot generate SPM files

CSC.KILL failed for activity:%d

CSC.SUBMIT %s %s %s failed

CSC.WAIT_CHILDREN failed for AD processes

CSC.WAIT_CHILDREN failed for CI processes

Error - invalid command line arguments

Error - running NAR_AD processes exist

Error closing audit file

Error closing audit files

Error from %s; status: %d

Error in opening %s
Error initialising audit file
Error initialising audit files
Error occurred writing batch %d of SPM data records
Error occurred writing SPM increment for meter:%s sett date:%s
Error while opening file %s
Error while writing SPM increment record
Error writing audit log
Error writing SPMATRIX record
Error writing Supplier record
Failed to clear aggregation queues
Failed to clear failed aggregation areas
Failed to determine no. of partitions
failed to extract parameters for process type %s
Failed to find DC Appointment for meter %s & date %s
Failed to find DC Details for Meter %s, DC %s
Failed to find Measurement Requirements for SSC %s
Failed to find PRS Details for meter %s & date %s
Failed to find Registrations for meter %s & date %s
Failed to get afyc for run %d & ssc %s
Failed to get ggpcaec for run %d & ssc %s
Failed to get threshold_par for run %d
Failed to perform Aggregate Data - abort
Failed to perform aggregation
Failed to perform Calculate Increments - abort
Failed to perform Generate Output
Failed to perform recovery for previous runs
failed to read batch %d of nar files
failed to update run status in ndb_data_agg_runs
Failed to update status to %s for run %d
Failed to obtain value for BSD system parameter
Failed to obtain value for SPI system parameter
Failed to obtain isra agent for GSP group %s
Field/record format invalid: %s
File could not be opened: %s
File creation failed: %s
File has deleted status: %s
File hdr/ptr write failed: %s
File open failed: %s
Insufficient number of arguments

invalid aggregation process %s
 Invalid aggregation run number %d
 Invalid date format
 Invalid directory path: %s
 Invalid invocation of Aggregate Data
 Invalid number of arguments (%d).
 Correct arguments are <run date> <recovery mode>
 run date is NOW or TONIGHT or YYYYMMDD
 recovery mode is START or RESTART or CONTINUE or ABORT.
 invalid parameter for AD invalid parameter for GO
 invalid parameter for CI
 Invalid recovery mode (%s)
 Invalid recovery mode:%s
 Invalid Run Status for run %d
 No GSP groups retrieved for run %d
 No ISRA appointed to GSPG:%s: for todays date
 No 'released' runs retrieved from ndb_data_agg_runs
 No run information for run %d
 No runs scheduled!
 No SPM rows for run %d, GSP Group %s
 No such file/directory in db: %s
 Null ISR Agent appointed to GSPG:%s: for todays date
 One or more AD processes completed unsuccessfully
 Records UPDATED (%d) doesn't match records FETCHED (%d)
 Run specified not expected
 Shutdown requested - exit immediately
 Too many (%d) Aggregation Runs
 Too many (> %d) Measurement Requirements exist on database
 Too many (> %d) SSCs exist on database
 Unexpected return status: %s
 Warning - extra text in date string - ignoring
 Warning - No. of aggregation runs retrieved exceeds maximum - only process the latest
 %d
 Warning: more than one previous aggregation was killed

A.1.2 Check Data Collector Data

Cannot read exceptions data - invalid input parameters
 cfs_export failed to export file:%.0f
 Could not copy record %s from original to new exceptions file
 Could not create new exceptions file
 Could not determine next record in original exception file

Could not open new exceptions file
Could not open new exceptions file (%.1f)
Could not open original exceptions file
CSC.KILL failed for activity:%d
CSC.WAIT_ALL (for GO processes) failed
CSC.WAIT_ALL failed
CSL failed closing file
CSL failed to copy record
CSL failed to create new record
CSL failed to determine record type
CSL failed to read next record
CSL failed to update count of metering systems with exceptions
CSL failed to update exception count
CSL failed to write field
CSL failed to write new exceptions file footer
CSL failed to write new record
CSL failed to write record
CSL failed writing file footer
CSL failed writing file header
Error - DC list out of synch
Error - Effective From Settlement Date not specified
Error - Effective To Settlement Date not specified
Error - invalid parameters
error - invalid state for exception counts
Error - No DCs were retrieved
Error - No exceptions retrieved for specified parameters
Error - Supplier not specified
Error allocating memory
Error occurred closing file
Error occurred closing new exception file
Error occurred closing original exception file
Error occurred fetching exceptions data
Error occurred opening empty exceptions file
Error occurred opening exceptions file
Error occurred updating file status
Error occurred writing file body
Error occurred writing file footer
Error occurred writing file headers
Error processing batch %d of cdc data runs data
Error reading exceptions data

Error writing batch %d of exceptions data
Failed to close exceptions cursor - invalid cursor type:%d
failed to copy file:%.1f to final exceptions file:%.1f
Failed to create new exception record
Failed to determine no. of partitions
failed to submit NCD_CE process for %s
Failed to write empty file: supplier<%s> dc<%s>
failed to write exception counts to file
failed to write exceptions details
failed to write ms record
failed to write prsa record
failed writing exceptions header
Insufficient number of arguments
Invalid DC:%s
Invalid number of function arguments(%d) - 5 expected
Invalid parameters
Invalid PRSA:%s
Invalid supplier:%s
One or more Calculate Exception processes failed
One or more Generate Output processes failed
Settlement date range not specified
Shutdown requested - exit immediately
Unexpected record <%s> - incorrect file format

A.1.3 Instruction Processing

Bad file additional header
Bad file header
Bad instruction header
Error - Insufficient Parameters.
Error - Parameter '%s' invalid.
Error %s or %s is not YYYYMMDD
Error : Originator not correct type
Error : Originator not currently assigned
Error encountered while closing the report file.
Error encountered while creating the report file.
Error encountered while requesting file transfer.
Error encountered while updating the report file's status.
Error encountered while writing to report file.
Error executing dynamic SQL

Error File (File Id = %.0Lf) is not Instruction File
Error getting file handle
Error on close
Error on file seek
Error on instruction type : %s
Error on instruction type : PRS Refresh
Error on open
Error on read
Error on record order : %s unexpected
Error on record type : %s unexpected
Error on tell
Error on update
Error retrieving partition
Error while writing field in INH
Error while writing field in INR
Error while writing field in MSH
Error while writing field in MSH
Error while writing INH record
Error while writing INR record
Error while writing MSH record
Error with record %d
Error: Too many detail changes on database
Error: Too many distributors on database
File handle error
Invalid operation: %c
Metering system %s is not in Distribution Business %s
Processing Error
Unable to generate filename
Unable to update file: %.0Lf
Unknown Distribution Business %s

A.1.4 Data Loading

Bad nld data file header
Data file has too many distinct isr_notification_dates
Error closing nld data file
Error closing nld exception report
Error creating nld exception report
Error getting alternate file name
Error on csl_update_file

Error on data file rewind
Error on get file handle
Error on time conversion
Error opening nld data file
Failed to write exception record
Failed to write to exception file

DRAFT

Comment Form

Document Title

Document Version

Version Date

If you have any comments on the accuracy and completeness of this document, please write them on a copy of this form and forward by email to the ELEXON Helpdesk at helpdesk@elexon.co.uk or contact the Helpdesk on telephone number 020 7380 4222

Comment no.	Section	Page	Comment
DRAFT			

Comments sent by: Organisation
 Name