

Draft MODIFICATION REPORT for Modification Proposal P224 'Reactive Power Flows Associated with Exemptable Generating Plant'

Prepared by: ELEXON¹ on behalf of the BSC Panel

Date of Issue:	18 August 2008	Document Reference:	P224RR
Reason for Issue:	For Consultation	Version Number:	0.2

This document has been distributed in accordance with Section F2.1.10 of the Balancing and Settlement Code.²

Proposed Modification P224 seeks to revise the Code to allow Reactive Power to be allocated to the Party responsible for the associated flow of Active Power (either Import or Export). The aim is to resolve anomalies in the allocation of Reactive Power flows on sites where Import demand (supplied by a Licensed Supplier) and Export from Exemptable Generating Plant (e.g. embedded wind powered generators) share a common connection to the Distribution System (referred to as 'shared sites' in this document).

Presently the Supplier responsible for the Active Import of such a shared site is held responsible for some Reactive Power flows caused by operation of the Exemptable Generating Plant, because the Code assigns the Reactive Power to the Import Metering System. This issue does not directly affect Settlement but can materially impact Distributors' ability to implement appropriate Distribution Use of System (DUoS) charging. P224 would allow Reactive Power to be more appropriately allocated for shared sites, and permit Distributors to improve DUoS charging.

No Alternative Modification has been developed.

BSC PANEL'S RECOMMENDATIONS

Having considered and taken into due account the contents of the P224 draft Modification Report, the BSC Panel recommends:

- **that Proposed Modification P224 SHOULD be made;**
- **an Implementation Date for Proposed Modification P224 of 5 November 2009 if an Authority decision is received on or before 5 February 2009, or 25 February 2010 if an Authority decision is received after 5 February 2009 but on or before 14 May 2009;**
- **the proposed text for modifying the Code, as set out in the Modification Report.**

¹ ELEXON Ltd fulfils the role of the Balancing and Settlement Code Company ('BSCCo').

² The current version of the Code can be found at <http://www.elexon.co.uk/bcsrelateddocs/BSC/default.aspx>

CONTENTS TABLE

Summary of Impacted Parties and Documents	3
1 P224 Summary	4
2 Description of Modification	7
3 Areas Raised by the Terms of Reference	10
4 Implementation Approach and Costs.....	11
5 Rationale for Modification Group’s Recommendations to the Panel	13
5.1 Assessment of Proposed Modification Against Applicable BSC Objectives	13
5.2 Final Recommendation to the Panel.....	15
5.3 Implementation Date	15
5.4 Legal Text.....	15
6 Rationale for Panel’s Recommendations to the Authority.....	15
6.1 Panel’s Consideration of Assessment Report	15
6.2 Results of Report Phase Consultation.....	18
6.3 Panel’s Consideration of Draft Modification Report	18
6.4 Panel’s Final Recommendation to the Authority	18
7 Terms Used in this Document	18
8 Document Control	19
8.1 Authorities	19
8.2 References	19
Appendix 1: Legal Text	20
Appendix 2: Process Followed	20
Appendix 3: Assessment Report	21
Appendix 4: Report Phase Consultation Responses	22

Intellectual Property Rights, Copyright and Disclaimer

The copyright and other intellectual property rights in this document are vested in ELEXON or appear with the consent of the copyright owner. These materials are made available for you for the purposes of your participation in the electricity industry. If you have an interest in the electricity industry, you may view, download, copy, distribute, modify, transmit, publish, sell or creative derivative works (in whatever format) from this document or in other cases use for personal academic or other non-commercial purposes. All copyright and other proprietary notices contained in the document must be retained on any copy you make.

All other rights of the copyright owner not expressly dealt with above are reserved.

No representation, warranty or guarantee is made that the information in this document is accurate or complete. While care is taken in the collection and provision of this information, ELEXON Limited shall not be liable for any errors, omissions, misstatements or mistakes in any information or damages resulting from the use of this information or action take in reliance on it.

SUMMARY OF IMPACTED PARTIES AND DOCUMENTS

As far as the Modification Group has been able to assess, the following parties/documents would be impacted by P224.

Please note that this table represents a summary of the full impact assessment results contained in Appendix 4.

Parties	Sections of the BSC	Code Subsidiary Documents
Distribution System Operators <input checked="" type="checkbox"/>	A <input type="checkbox"/>	BSC Procedures <input checked="" type="checkbox"/>
Generators <input checked="" type="checkbox"/>	B <input type="checkbox"/>	Codes of Practice <input checked="" type="checkbox"/>
Interconnectors <input type="checkbox"/>	C <input type="checkbox"/>	BSC Service Descriptions <input type="checkbox"/>
Licence Exemptable Generators <input checked="" type="checkbox"/>	D <input type="checkbox"/>	Party Service Lines <input type="checkbox"/>
Non-Physical Traders <input type="checkbox"/>	E <input type="checkbox"/>	Data Catalogues <input type="checkbox"/>
Suppliers <input checked="" type="checkbox"/>	F <input type="checkbox"/>	Communication Requirements Documents <input type="checkbox"/>
Transmission Company <input type="checkbox"/>	G <input type="checkbox"/>	Reporting Catalogue <input type="checkbox"/>
Party Agents		
Data Aggregators <input type="checkbox"/>	H <input type="checkbox"/>	Core Industry Documents
Data Collectors <input checked="" type="checkbox"/>	I <input type="checkbox"/>	Ancillary Services Agreement <input type="checkbox"/>
Meter Administrators <input type="checkbox"/>	J <input type="checkbox"/>	British Grid Systems Agreement <input type="checkbox"/>
Meter Operator Agents <input checked="" type="checkbox"/>	K <input checked="" type="checkbox"/>	Data Transfer Services Agreement <input type="checkbox"/>
ECVNA <input type="checkbox"/>	L <input checked="" type="checkbox"/>	Distribution Code <input type="checkbox"/>
MVRNA <input type="checkbox"/>	M <input type="checkbox"/>	Distribution Connection and Use of System Agreement <input type="checkbox"/>
BSC Agents		
SAA <input type="checkbox"/>	N <input type="checkbox"/>	Grid Code <input type="checkbox"/>
FAA <input type="checkbox"/>	O <input type="checkbox"/>	Master Registration Agreement <input checked="" type="checkbox"/>
BMRA <input type="checkbox"/>	P <input type="checkbox"/>	Supplemental Agreements <input type="checkbox"/>
ECVAA <input type="checkbox"/>	Q <input type="checkbox"/>	Use of Interconnector Agreement <input type="checkbox"/>
CDCA <input type="checkbox"/>	R <input type="checkbox"/>	BSCCo
TAA <input type="checkbox"/>	S <input type="checkbox"/>	Internal Working Procedures <input type="checkbox"/>
CRA <input type="checkbox"/>	T <input type="checkbox"/>	BSC Panel/Panel Committees
SVAA <input type="checkbox"/>	U <input type="checkbox"/>	Working Practices <input type="checkbox"/>
Teleswitch Agent <input type="checkbox"/>	V <input type="checkbox"/>	Other
BSC Auditor <input type="checkbox"/>	W <input type="checkbox"/>	Market Index Data Provider <input type="checkbox"/>
Profile Administrator <input type="checkbox"/>	X <input checked="" type="checkbox"/>	Market Index Definition Statement <input type="checkbox"/>
Certification Agent <input type="checkbox"/>		System Operator-Transmission Owner Code <input type="checkbox"/>
Other Agents		
Supplier Meter Registration Agent <input type="checkbox"/>		Transmission Licence <input type="checkbox"/>
Unmetered Supplies Operator <input type="checkbox"/>		
Data Transfer Service Provider <input type="checkbox"/>		

1 P224 SUMMARY

P224 solution

P224 will amend the Code so that responsibility for Reactive Power is allocated to the Party responsible for the associated flow of Active Power. The Metering Systems of Half Hourly settled shared Import/Export sites will need to be capable of allocating Reactive Power to the Import or Export MSID on the basis of this methodology, though this requirement will not apply retrospectively.

LDSOs would not be obliged to make changes to their DUoS billing systems under P224. However, it is anticipated that LDSOs would amend their billing systems to ensure that the appropriate Party receives accurate charges relating to Reactive Power. This is because LDSOs would have access to more accurate data to allocate charges, and would be able to avoid the use of workarounds and reduce the likelihood of issues and disputes arising.

Main Arguments against the BSC Objectives

The Group established the following benefits against the Applicable BSC Objectives arising from P224:

- P224 allows for appropriate cost signals to be sent to participants regarding Reactive Power which will tend to ultimately facilitate efficient operation of the Transmission System - Objective (b)³; and
- P224 will rectify the inappropriate allocation of Reactive Power and associated DUoS charges and thereby remove a barrier to participation in the market - Objective (c)⁴.

Identified Costs

The Group noted that the implementation costs for the Proposed Modification were estimated to be circa **£71,000** (for the mandatory required changes to Party Agent systems and for amendment by ELEXON of the Code, CoPs and BSCPs to give effect to P224).

Materiality

The Group determined an estimate of the current materiality associated with the issue of inappropriate allocation of Reactive Power to be:

- Export Parties may be undercharged by £1.7 - 3.3M per annum; and
- Import Parties may be overcharged by £113.5 - 219.7M per annum.

The materiality is based on a comparison of the estimated current charging and potential 'P224' charging in relation to shared Import/Export sites, and assumes all charges that are calculated and assigned under the current charging methods are in fact levied in full (i.e. LDSOs do not 'shield' Parties from Reactive Power related charges).

The Group highlighted that the amount of distributed generation could be assumed to increase eightfold by 2020, in line with targets for electricity generation using renewable sources.

³ Applicable BSC Objective (b) - efficient, economic and co-ordinated operation of the GB transmission system

⁴ Applicable BSC Objective (c) - promoting effective competition in the generation and supply of electricity, and (so far as consistent therewith) promoting such competition in the sale and purchase of electricity

Cost-Benefit

The Group estimated that the costs incurred by full progression of the P224 solution (i.e. including anticipated but non-mandatory changes to LDSO and Supplier charging systems) for Parties would be:

- Industry Implementation cost - **£335,000**; and
- Estimated potential⁵ **increase** in distribution charges to Generators - **£1M** per annum⁶ until 2020 (i.e. a year on year increase, spread over all Generators associated with materially affected shared sites).

The Group estimated that the costs saved by full progression of the P224 solution for Parties would be:

- Avoidance of single LDSO implementation of alternative Reactive Power solution - **£200,000**;
- Increased cost to LDSOs of workarounds - **£200,000** per annum (NB – based on IA response information and assuming all workarounds already in place would remain operational); and
- Avoidance of an estimated potential **increase** in the materiality of the P224 issue to Import Parties of **£75M**⁷ per annum⁸ until 2020 (i.e. a year on year increase spread over all Import Parties associated with materially affected shared sites).

Impact on Metering Codes of Practice and Half Hourly Settled Sites

The detailed requirements of P224 will be effected by the specific metering requirements within the Codes of Practice (CoP). This table describes these metering requirements at a high level, and notes the effect on Metering Systems governed by each CoP.

The information in this table is an extracted summary of information in the 'Impact on Code Subsidiary Documents' table in the P224 Assessment Report in Appendix 3. Further details of the impacts on Metering CSDs can be found in Attachment 7 to the P224 Assessment Report, 'Impact of P224 on Metering CSDs'.

Code of Practice	P224 Implementation Impact	Effect of P224
CoP1 'The Metering of Circuits with a Rated Capacity Exceeding 100MVA for Settlement Purposes'	Amendment to specify Reactive Energy requirements to effect P224 solution.	P224 solution applies.
CoP2 'The Metering of Circuits with a Rated Capacity not exceeding 100 MVA for Settlement Purposes'	Amendment to specify Reactive Energy requirements to effect P224 solution.	P224 solution applies.
CoP3 'The Metering of Circuits with a Rated Capacity not exceeding 10 MVA for Settlement Purposes'	Amendment to specify Reactive Energy requirements to effect P224 solution.	P224 solution applies.
CoP5 'The Metering of Energy Transfers with Max Demand of up to (and including) 1MW for Settlement Purposes'	Amendment to specify Reactive Energy requirements to effect P224 solution; additional amendment to mandate Reactive Power Demand Values.	P224 solution applies; Reactive Power requirements align with CoPs 1, 2 and 3.

⁵ Alteration in the operating behaviour of Generators due to the new allocation of Reactive Energy under the P224 solution may reduce this impact.

⁶ Calculated by applying the Group's *conservative* charge estimate, assuming a linear increase in Distributed Generation to meet energy targets set and assuming no change to Generator operation due to P224.

⁷ Note that any increase due to increased charges by LDSOs would be limited by the cap applied to the amount of revenue LDSOs are permitted to recover.

⁸ Calculated by applying the Group's *conservative* charge estimate, assuming a linear increase in Distributed Generation to meet energy targets set and assuming all charges are applied, i.e. LDSOs do not employ workarounds to 'shield' Parties from Reactive Power related charges – note that Ofgem has indicated to LDSOs that they should charge in relation to Reactive Power.

CoP6 'Code of Practice for the Metering of Energy Imports via Low Voltage Circuits Fused at 100 Amps or Less Per Phase for Settlement Purposes'	No direct impact for P224 implementation.	P224 Code requirements effectively rule out the use of CoP6 Meters for Half Hourly Settlement.
CoP7 'Code of Practice for the Metering of Energy Imports via Low Voltage Circuits Fused at 100 Amps or Less Per Phase for Settlement Purposes'	No direct impact for P224 implementation.	Similar impact as that under CoP6.
Proposed Smart Metering CoP: CoP10 'Code of Practice for Whole Current Metering of Energy via Low Voltage Circuits for Settlement Purposes'	CoP10 document is currently being drafted; if P224 is implemented it is recommended that CoP10 should specify that measurement of Reactive Energy is not required (under the BSC, as provided for in the P224 solution).	Implementing P224 in the way recommended (i.e. such that CoP10 specifies that measurement of Reactive Energy is not required) would avoid a negative impact on Smart Metering by ensuring the requirements of CoP10 are not unduly onerous.

Implementation

The Group agreed an Implementation Date for the Proposed Modification of:

- 5 November 2009 if an Authority decision is received on or before 5 February 2009; or
- 25 February 2010 if an Authority decision is received after 5 February 2009 but on or before 14 May 2009.

The Group agreed that the draft legal text delivers the intended solution for the Proposed Modification.

A description of the P224 solution is provided in Section 2. Further information regarding the Group's discussions of the areas set out in the P224 Terms of Reference is contained in Section 3 of the P224 Assessment Report. The areas documented are listed in Section 3 of this document. Section 3.7 of the Assessment Report gives more information on the cost-benefit assessment.

A summary of the Group's views regarding the merits of the Proposed Modification can be found in Section 5, and Section 6 contains the rationale behind the Panel's recommendations to the Authority. Summaries of the responses to the Assessment Procedure consultation and impact assessment can be found in the P224 Assessment Report Appendices 3 and 4 respectively.

The P224 Assessment Report and attachments can be found on the P224 page of the ELEXON website:

<http://www.elexon.co.uk/changeimplementation/ModificationProcess/modificationdocumentation/modProposalView.aspx?propID=248>.

2 DESCRIPTION OF MODIFICATION

This section outlines the solution for the Proposed Modification, as developed by the P224 Modification Group ('the Group') during the Assessment Procedure.

For a full description of the original Modification Proposal as submitted by E.ON UK plc ('the Proposer'), and the background to the proposal, please refer to the [P224 Initial Written Assessment \(IWA\)](#).

Code Changes

The Proposed Modification solution is that changes are made to the rules in the BSC which govern the allocation of volumes of Reactive Power. The issue identified by P224 arises when two Parties share a common connection to the distribution system of an Import/Export site, and therefore different Parties are responsible for Import and Export, though complications can also arise due to allocation to the inappropriate MSID even where only one Party is associated with an Import/Export site. The aim is that responsibility for Reactive Power flows is allocated more appropriately, by associating it with the flow of Active Power occurring at the same time. This will be accomplished by configuring the Meter to allocate Reactive Power to one of four registers, on a moment by moment basis, depending on both the direction of the Active Power flow and whether the Reactive Power is conventionally labelled 'Import' or 'Export' (i.e. whether it is leading or lagging). This is a change from current arrangements, which require only two Reactive Power registers. These changes in the BSC (and associated metering arrangements) will necessitate consequential changes to metering Codes of Practice (CoPs) and other Code Subsidiary Documents (CSDs).

No Retrospection

It should be noted that the solution proposed is not retrospective and is intended to align with the approach applied to the metering CoPs, i.e. that Metering Systems have to comply with the requirements (i.e. the version of the relevant CoP) in place when the site is first registered for the purposes of Settlement, as per Sections L and K of the Code. Therefore an existing shared Import/Export site will not be required to comply with the P224 rules until such time as a material change to its Metering Equipment means that, in accordance with Section L of the Code, a version of a CoP which requires compliance with P224 becomes relevant to the site. A material change to the Metering Equipment is described in Section L, and is a substantial alteration, such as replacement of a the Metering System's current transformers.

A change of Party associated with the Import and/or Export MSID of a Metering System **would not** on its own trigger a change to the CoP requirements for the site, and therefore *would not necessitate compliance with the P224 provisions*.

Availability of P224 compliant Meters

A number of currently available Meters are capable of compliance with the P224 provisions, or can be made compliant with only minor changes to the Meter software to adjust how the Meter carries out allocation of Reactive Power to its registers. These registers are subsequently linked to the Import or Export MSID via the configuration of the Meter Technical Details (MTD). For any new registrations or material changes to Metering Equipment of shared Import/Export sites Parties will need to ensure that the site complies with P224, where applicable. The action required will depend on the capabilities of the Settlement metering in place at the time.

Configuration of Meter Registers

Currently four Measurement Quantity IDs are used for Meter Registers: Active Export (AE), Active Import (AI), Reactive Export (RE) and Reactive Import (RI). For shared Import/Export sites, the BSC prescribes that AE volumes are allocated to the Party associated with the Export of the site ('the Export Party') and AI volumes are allocated to the Party associated with the site's Import ('the Import Party').

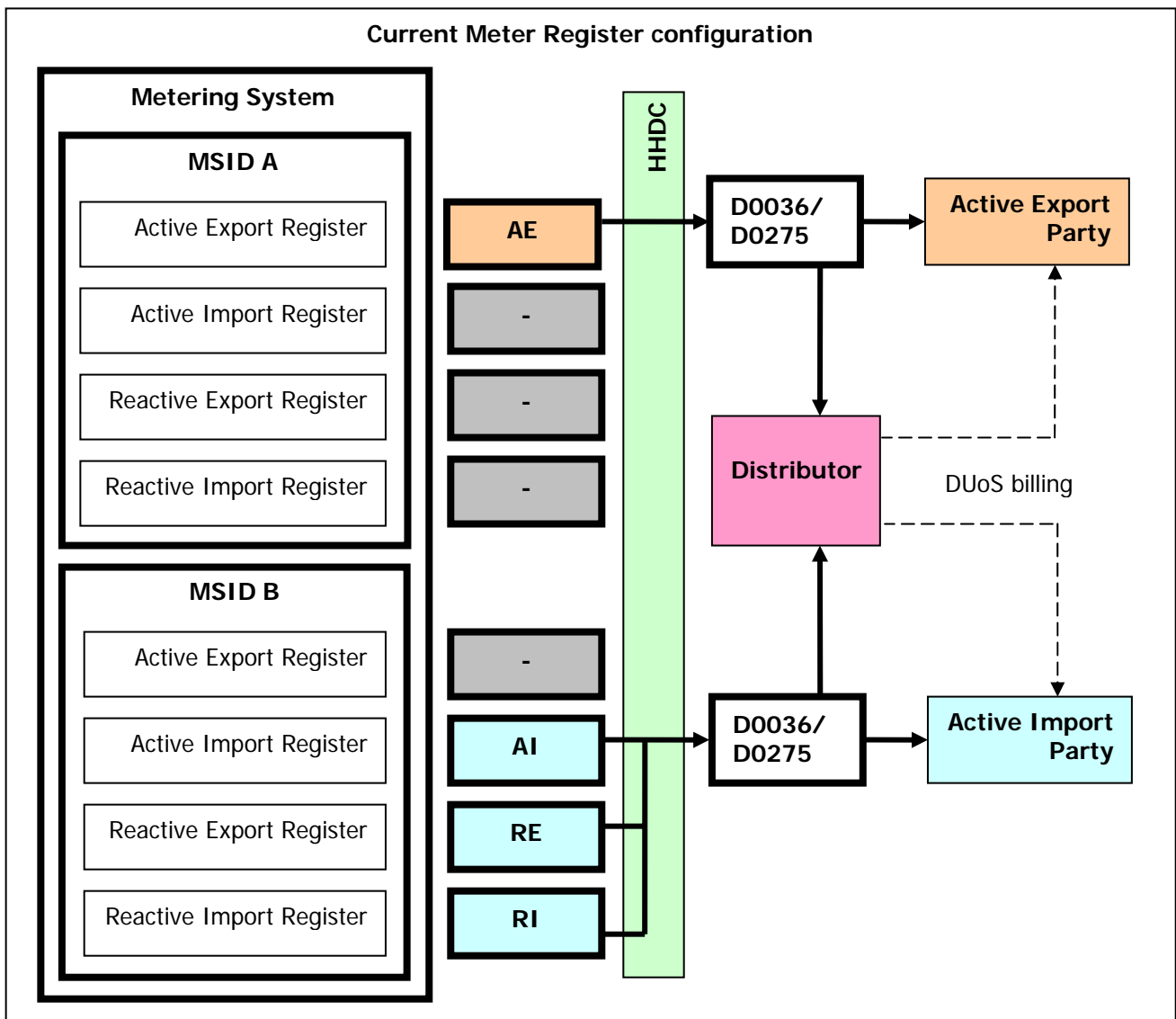

Figure 1: Current Meter Register configuration

The current BSC baseline obliges the Import Party to be allocated the RI volumes for shared Import/Export sites, and permits either the Import Party or the Export Party to be allocated the RE volumes for such sites. In practice both the RE and RI volumes are normally allocated to the Import Party (irrespective of whether those Reactive Power flows are associated with Active Import or Active Export). These configurations of the Meter Registers are translated into the structure of the data flows from HHDCs (or as the case may be the CDCA) which report RE and RI volumes to the Party and the relevant Licensed Distribution System Operator (LDSO), as shown in figure 1.

Under the P224 Proposed solution the Meter Register Measurement Quantity IDs would not be changed. The Group considered arguments that an additional 4 Measurement Quantities should be introduced to reduce the risk of errors occurring in initial set up. Any amendment of the Meter Register Measurement Quantity IDs would significantly increase the impact of implementation of the P224 solution on a number of Parties. The Group concluded that it was not necessary to change or supplement the existing Meter Register Measurement Quantity IDs in order for the P224 solution to function.

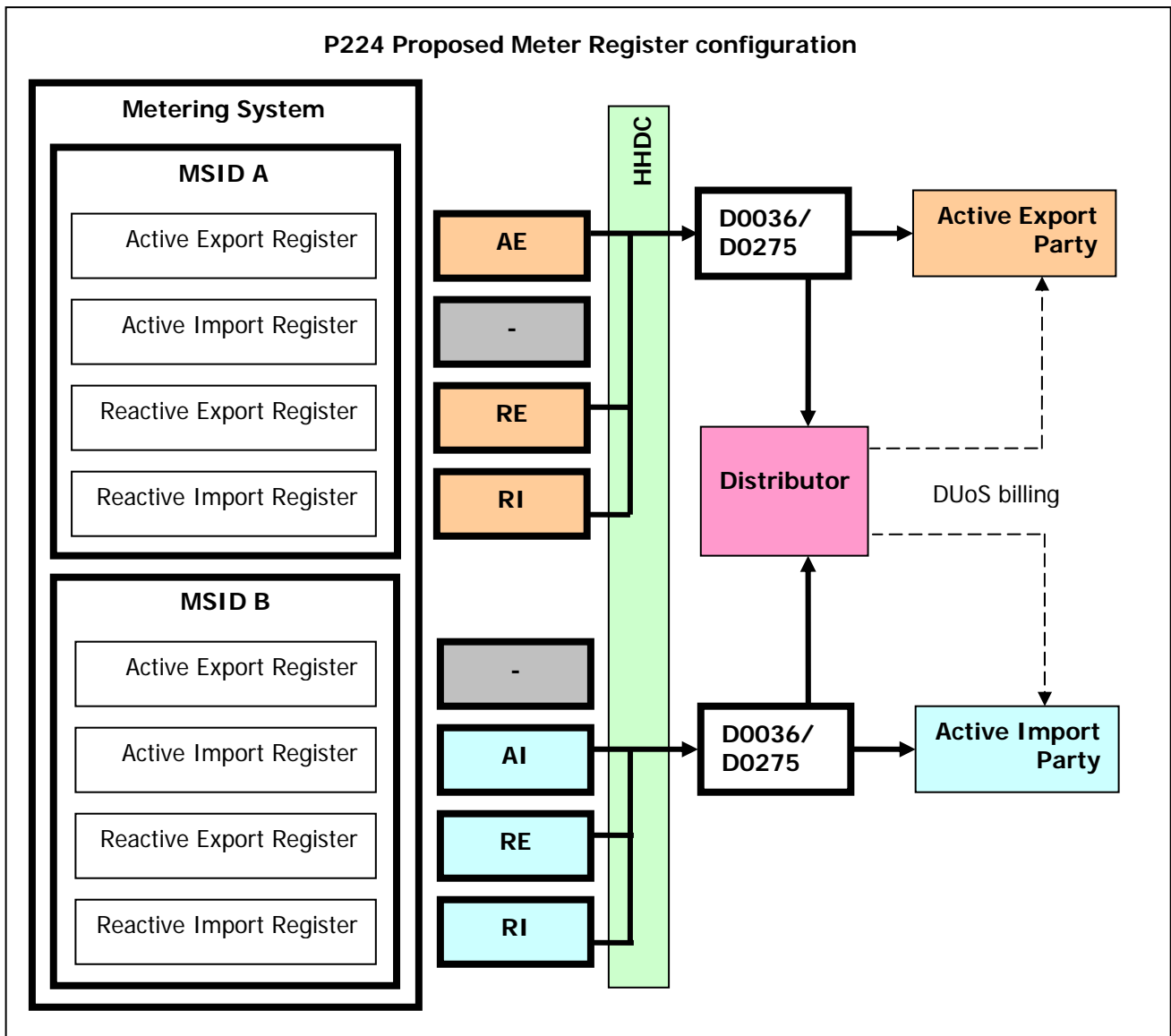

Figure 2 P224 Proposed Meter Register configuration

The proposed configuration of Meter Registers under P224 is illustrated in figure 2. Note that under P224 the existing Measurement Quantities will be used as follows:

- Measurement Quantity 'RI' (Reactive Import) on the Export MSID for leading power flows associated with Active Export;
- Measurement Quantity 'RE' (Reactive Export) on the Export MSID for lagging power flows associated with Active Export;
- Measurement Quantity 'RI' (Reactive Import) on the Import MSID for lagging power flows associated with Active Import;
- Measurement Quantity 'RE' (Reactive Export) on the Import MSID for leading power flows associated with Active Import.

If registers are configured as intended and Meter software is appropriately amended then the Metering Systems of shared Import/Export sites can allocate Reactive Power to the appropriate MSID as determined by the allocation methodology of the P224 solution. Guidance would be added to Annex C of the Master Registration Agreement (MRA) Data Transfer Catalogue regarding the new register configuration (see section 3.3).

Provision for alternative approaches to Reactive Power within CoPs within specific limits

The provisions of the P224 solution apply to shared Import/Export sites that are settled on a Half Hourly basis unless such a site meets both of the following criteria:

- Its use of Half Hourly metering is not mandatory (i.e. its Import is below the threshold for mandatory Half Hourly metering, currently 100kW, and its Export is below the microgeneration limit, currently set at 30kW); **and**
- There is specific provision for exception from the P224 provisions in the applicable metering CoP.

It is not proposed that such a provision permitting alternative arrangements be included in any of the existing Half Hourly CoPs. This option is intended for future CoPs that may be created for smart metering (or other similar applications). The Group believes this provision should be applied to the proposed CoP10 which is currently being assessed (see [DCP0033](#) ELEXON webpage).

The applicability of a CoP to a site is determined by the characteristics of that site, not by the Meter installed. This means even if the Meter installed on a site can measure Reactive Power, it is not required to do so unless the CoP applicable to the site requires that it must.

The Group agreed that P224 should include a materiality threshold and criteria to determine whether the P224 provisions should apply. The Group were primarily concerned with ensuring the solution did not create a potential barrier to competition by preventing the utilisation of future technology that may provide for small scale generation and Import, but not have any material issue relating to Reactive power allocation. The criteria detailed above are believed to accomplish this, as they allow the CoPs to be revised through the BSC Change Proposal (CP) process to accommodate any such technology, while maintaining an obligation on mandatory Half Hourly metered sites which cannot be changed by a CP.

3 AREAS RAISED BY THE TERMS OF REFERENCE

The following areas were considered by the Modification Group during the Assessment Procedure for P224:

- Implications for parties affected by the issues caused by Reactive Power flows associated with Exemptable Generating Plant;
- System impacts;
- Impacts on any other codes or documentation (e.g. BSCPs, CoPs)
- Impact on CVA metering arrangements;
- Implications and implementation of proposed materiality threshold;
- Evidence and analysis regarding the defect;
- Cost-benefit of P224;
- Assessment of the means of Reactive Power allocation; and
- Environmental Impact.

These issues are discussed in the Assessment Report contained in Appendix 3, and are not covered further here.

4 IMPLEMENTATION APPROACH AND COSTS

Results of Proposed Modification Impact Assessment

PROPOSED MODIFICATION IMPLEMENTATION COSTS⁹

	Implementation Cost ¹⁰	Tolerance
Total Demand Led Implementation Cost	£65,000 ¹¹	+/- 10%
ELEXON Implementation Resource Cost	30 man days £6,600	+/- 10%
Total Implementation Cost	£71,000	+/- 10%

The P224 assessed Implementation costs have not changed from those provided in the Assessment Report.

a) BSC Agent Impact

No BSC Agent impact identified.

A potential impact on the CDCA was assessed; this impact was that system changes might have been needed due to the requirement that the CDCA system is able to accommodate the Meter Register configuration necessary for the P224 Proposed solution. However, the CDCA service provider impact assessment confirms the current CDCA system is able to do this, and there is therefore no impact on the CDCA.

Further details of the assessment of BSC Agent impacts can be found in the P224 Assessment Report in Appendix 3.

b) BSC Party and Party Agent Impact

HHDC and MOA

- Process and system changes;
- Training and documentation of new procedures; and
- Sourcing meters compliant with the P224 provisions.

Generally, required lead times identified for these activities range from 2 – 6 months. The associated costs are generally low, estimated at a total of £5,000 for all but one of the HHDC/MOA respondents to complete the required activities.

However - one HHDC identified a more significant impact, due to particular requirements to upgrade and test its data management system. The estimated lead time for this work is 12 - 18 months, at an estimated cost of £60,000.

⁹ An explanation of the cost terms used in this section can be found on the BSC Website at the following link: http://www.elexon.co.uk/documents/Change_and_Implementation/Modifications_Process_-_Related_Documents/Clarification_of_Costs_in_Modification_Procedure_Reports.pdf

¹⁰ Note that these are the maximum costs associated with implementation of P224 in a scheduled BSC Release; costs associated with project management etc may be reduced if other changes which impact the same areas are implemented in the same Release.

¹¹ This cost is for changes to Party Agent systems which are mandatory for P224 implementation; costs for changes by LDSOs and Suppliers which are anticipated but not mandatory under the BSC are not included.

LDSO and Supplier

The main impact of P224 implementation would generally be on LDSOs; however, the impacts are not obligatory. The changes identified by LDSOs are not directly necessary for implementation of P224 under the BSC, and the P224 solution cannot mandate that LDSOs make changes to their billing systems as this area is outside the scope of the BSC.

Some LDSOs reported no impact at all because they do not specifically charge for Reactive Power at present. Impacted LDSOs identified that changes would be needed to their DUoS billing systems, with implementation lead times of 6 - 9 months and associated costs ranging from £20,000 – 100,000 per LDSO.

Some Suppliers identified possible impacts to their billing systems and processes. One identified a 9 month lead time for implementation with costs of £50,000.

The impacts are considered non-mandatory for implementation of P224. These identified impacts might potentially be neglected in assessing the impact of P224 and planning its implementation.

The Group's view was that LDSO impacts would be directly relevant only if they concerned activities directly necessary for the implementation of P224, such as the ability to receive an impacted data flow or training staff in a revised registration process.

Note that the 'non-mandatory' impacts identified *are included* in the P224 cost benefit assessment. Though these changes are not directly required for implementation of the P224 solution from a BSC perspective, they are necessary for full realisation of the anticipated P224 benefits. The total cost identified by LDSOs and Suppliers for non-mandatory P224 related changes is £270,000.

Further details of the impact on Parties and Party Agents can be found in the P224 Assessment Report in Appendix 3.

c) Transmission Company Impact

The Transmission Company identified no anticipated impact or issues as a result of P224.

The Transmission Company analysis noted a potential CUSC Amendment Proposal may amend the arrangements in the Mandatory Services Agreement (MSA) for the provision of Reactive Power from embedded generation. Though it is not yet clear whether this proposal and related work will impact on or interact with P224, at present it is considered unlikely. The full Transmission Company Analysis and Impact Assessment can be found in the P224 Assessment Report in Appendix 3.

The Transmission Company Impact Assessment was updated following identification by the Group of a benefit of P224 against Applicable BSC Objective (b), as discussed in Section 3.9 of the P224 Assessment Report; this additional update is also in the P224 Assessment Report in Appendix 3.

d) BSCCo Impact

ELEXON would implement P224 as part of a BSC Release. ELEXON would make the changes to the Code, metering CoPs and BSCPs needed to give effect to the P224 solution.

ELEXON would also provide support and guidance to Parties implementing P224 in their systems and processes, and would provide support regarding any audit changes due to the revised requirements.

ELEXON's operational working procedures would also need to be updated to reflect the revised requirements; monitoring of submission of MTDs may potentially be undertaken.

The activities directly required for implementation of P224 by ELEXON (i.e. amendment of documentation and internal procedures) can be completed within around a month, at a cost of approximately £6,600. The support activities will continue over the period of P224 implementation by Parties, and any monitoring and operational changes will be ongoing; all these costs would be absorbed into ELEXON's operating costs.

See Appendix 3 for a detailed list of BSCCo impacts.

5 RATIONALE FOR MODIFICATION GROUP'S RECOMMENDATIONS TO THE PANEL

This section summarises the recommendations of the Modification Group, as detailed in the Assessment Report in Appendix 3.

5.1 Assessment of Proposed Modification Against Applicable BSC Objectives

5.1.1 Modification Group's Initial Discussions

This section outlines the initial views of the Modification Group regarding the merits of P224 against the Applicable BSC Objectives.

The initial **UNANIMOUS** view of the Modification Group was that the Proposed Modification **WOULD** better facilitate the achievement of Applicable BSC Objectives (b) and (c) when compared to the current Code baseline, for the following reasons:

Applicable BSC Objective (b)

- Levying accurate and correctly targeted charges relating to Reactive Power tends to have a positive impact on the operation of the Transmission System, as appropriate cost signals are sent to Parties which encourages them to consider the most economic manner of operation;
- If it is in Parties' economic interest to reduce the amount of Reactive Power they cause, this will tend to reduce the amount of Reactive Power on the Transmission System, which will reduce the actions National Grid is required to take to compensate for Reactive Power.

Applicable BSC Objective (c)

- Reactive Power would be allocated more appropriately and accurately to the Party actually responsible for them (or the MSID they should logically be assigned to), and therefore DUoS charges relating to Reactive Power will be more accurate and targeted correctly;
- More accurate DUoS charges relating to Reactive Power, and more correct targeting of charges to Parties actually responsible for Reactive Power flows, will facilitate competition;
- More appropriate allocation and metering of Reactive Power would facilitate potential creation of a competitive market in trading Reactive Power volumes;
- More appropriate allocation and metering of Reactive Power would facilitate a market for ancillary services for Exemptable Generating Plant, removing a potential barrier to the creation of new plant if Suppliers were reluctant to provide services due to inflated DUoS bills caused by inappropriate allocation of Reactive Power;
- The additional, more accurate data available would allow LDSOs not currently charging for Reactive Power to do so, and would facilitate competition in Distribution System operation to the benefit of Generators and Suppliers, thereby promoting competition among these participants and encouraging entry into the market; and
- Facilitate competition between Import Suppliers to Exemptable Generating Plant, as currently plant of this type are potentially restricted in their ability to switch Import Supplier due to reluctance by Suppliers to risk exposure to inflated DUoS bills.

The Group agreed that the Proposed Modification would have a neutral impact on Applicable BSC Objectives (a) and (d).

5.1.2 Views of Respondents to Assessment Procedure Consultation

The **UNANIMOUS** view of respondents to the Assessment Procedure consultation was that the Proposed Modification **WOULD** better facilitate the achievement of the **Applicable BSC Objectives**. Not all respondents identified benefits against specific Objectives, but of those that did specify particular Objectives:

- All stated that **Objective (c)** would be better facilitated for the reasons given by the Group;
- The majority stated that **Objective (b)** would be better facilitated for the reasons given by the Group; and
- One stated that **Objective (d)** would be better facilitated due to the avoidance of the need for workarounds by LDSOs and Suppliers and the reduction of the administrative burden.

5.1.3 Modification Group's Assessment

The **UNANIMOUS** view of the Modification Group was that the Proposed Modification **WOULD** better facilitate the achievement of **Applicable BSC Objectives (b) and (c)** when compared to the current Code baseline, for the following reasons:

Applicable BSC Objective (b)

- For the same reasons set out in its initial discussions; and
- There would be a positive environmental impact due to:
 - Transmission of Reactive Power would be reduced, causing a reduction in transmission losses;
 - Transmission of Reactive Power would be reduced, allowing the deferral of activities to increase transmission capacity and/or Reactive Power compensation which would otherwise need to be undertaken sooner; and
 - A potential ancillary market in Reactive Power would be facilitated, which could provide another option for the management of Reactive Power by enabling employment of participants to produce or absorb Reactive Power as necessary, instead of utilising conventional means of mitigating the effect of Reactive Power (i.e. increased transmission capacity and/or Reactive Power compensation) whose construction would have a negative environmental impact.

Applicable BSC Objective (c)

- For the same reasons set out in its initial discussions.

The Group noted that the primary benefits of the Proposed Modification are against Objective (c), the anticipated improvement of facilitation of Objective (b) being less substantial and less quantifiable.

The Group agreed that the Proposed Modification would have a neutral impact on Applicable BSC Objectives (a) and (d). However, one Group member noted that while the impact of P224 on Objective (d) is neutral because there is no impact on efficiency in relation to the Balancing and Settlement arrangements, the member believed that there would be an efficiency benefit for the UK electricity market arrangements as a whole.

5.2 Final Recommendation to the Panel

On the basis of the above assessment, the Modification Group therefore agreed a **UNANIMOUS** recommendation to the Panel that the Proposed Modification **SHOULD** be made.

5.3 Implementation Date

The Modification Group agreed the following recommended implementation approach for P224:

- An Implementation Date for the Proposed Modification of 5 November 2009; and
- A fall back Implementation Date for the Proposed Modification of 25 February 2010.

In considering Implementation Dates the Group noted the impact on LDSOs, which is material but not directly mandated by P224. However, the Group concluded that a coordinated implementation of P224 by all impacted Parties, including the impact on LDSOs, would be beneficial for all the market participants affected by P224, and therefore agreed the dates above.

5.4 Legal Text

The Group discussed the legal text required to implement the P224 via the Code, and concluded that Code changes should be kept to a minimum. The detail of the P224 solution requirements, such as metering requirements, will be set out in metering CoPs and BSCPs. The Group concluded that the Code should be amended to include the definitions necessary for P224, the basic principles of the P224 solution and to specify the circumstances in which different arrangements with regard to Reactive Power would apply.

The Modification Group reviewed by correspondence the draft legal text, and agreed that it delivers the P224 solution developed by the Group. A copy of the draft legal text can be found in Appendix 1, with a plain-English explanation.

6 RATIONALE FOR PANEL'S RECOMMENDATIONS TO THE AUTHORITY

6.1 Panel's Consideration of Assessment Report

The Panel considered the P224 Assessment Report at its meeting on 14 August 2008. This section summarises the Panel's discussions in formulating its provisional recommendation for inclusion in the draft Modification Report. Details of the Report Phase consultation responses, the Panel's discussion of the responses and its final recommendation to the Authority can be found in Sections 6.2, 6.3 and 6.4 respectively.

Assessment Procedure Consultation Responses

The Panel noted that the respondents to the P224 Assessment Procedure consultation unanimously agreed that P224 would better facilitate Applicable BSC Objectives (b) and (c).

The Panel also noted that there was significant majority support among respondents for:

- The Group's assessment that P224 would deliver appropriate Reactive Power-related charging;
- Provision within the P224 solution for individual CoPs to specify alternative approaches to Reactive Power measurement where appropriate (and only for sites where HH Settlement is non-mandatory); and
- Implementation of P224 in November 2009.

Further details of the P224 Assessment Procedure consultation can be found in the P224 Assessment Report in Appendix 3.

Environmental Benefit of P224 under Applicable BSC Objective (b)

The Panel agreed with the Group's assessment that there would be a positive environmental impact due to P224, which would fall under Objective (b), though such benefit was marginal and based upon theoretical assumptions. The Panel was satisfied with the Group's qualitative assessment of the environmental impact of P224, given that this did not form part of the P224 ToR and that the impact was marginal and not the main argument in relation to P224.

The Panel noted the view of National Grid that while they agree P224 has the potential to better facilitate Objective (b) due to beneficial environmental impact, they do not believe such benefit has been shown to be material. National Grid believes that the material benefit of P224 is against Objective (c). These views align with those expressed in the P224 Transmission Company Analysis and updated Analysis, which can be found in the P224 Assessment Report.

Provision for alternative approaches to Reactive Power within CoPs

The Panel noted the Group's discussions in the P224 Assessment Report regarding a potential P224 materiality threshold and provision for alternative Reactive Power approaches within CoPs. A Panel member noted that the reference in Section 3.5 of the Assessment Report to the Energy Retail Association's (ERA) smart Meter specification non-inclusion of Reactive Power measurement was not accurate; the ERA specification does in fact contain requirements/guidance for Reactive Power measurement.

The Panel member who had raised this issue did not believe that it impacted on the overall aim of ensuring that P224 does not have a negative impact on the viability of smart metering and elective Half Hourly Settlement, which is the reason behind the provision in the P224 solution for alternative Reactive Power approaches within particular CoPs. The Panel agreed that this aim is valid and agreed with the approach for allowing some latitude in individual CoPs for different approaches to Reactive Power measurement.

Impact of no retrospection

A Panel member noted that both the Import and Export Parties associated with a shared site would need to give permission for the meter changes needed to deliver P224 the solution for a site. Therefore one Party could potentially frustrate introduction of the P224 solution to a site, disadvantaging the other Party.

The Panel noted that the Group had discussed this point, and had agreed that discontinuation of both LDSO workarounds and shielding of Parties from Reactive Power related charges would tend to place a commercial incentive on all types of Party to seek to introduce P224. This incentive would be driven by a desire to avoid inflated charges due to inappropriately allocated Reactive Power and inaccurate Reactive Power related DUoS charges.

The Panel accepted the arguments put forth by the Group. The Panel member who had raised the issue also agreed, but believed that in the case that one Party were to frustrate introduction of the P224 solution by another Party the situation may culminate in an issue being raised with Ofgem to seek resolution of the disagreement.

Applicable BSC Objectives

The **UNANIMOUS** provisional view of the Panel was that the Proposed Modification **WOULD** better facilitate the achievement of Applicable BSC Objectives (b) and (c) when compared to the current Code baseline, for the following reasons:

Applicable BSC Objective (b)

- Levying accurate and correctly targeted charges relating to Reactive Power tends to have a positive impact on the operation of the Transmission System, as appropriate cost signals are sent to Parties which encourages them to consider the most economic manner of operation;

- If it is in Parties' economic interest to reduce the amount of Reactive Power they cause, this will tend to reduce the amount of Reactive Power on the Transmission System, which will reduce the actions National Grid is required to take to compensate for Reactive Power; and
- There would be a positive environmental impact due to:
 - Transmission of Reactive Power would be reduced, causing a reduction in transmission losses;
 - Transmission of Reactive Power would be reduced, allowing the deferral of activities to increase transmission capacity and/or Reactive Power compensation which would otherwise need to be undertaken sooner; and
 - A potential ancillary market in Reactive Power would be facilitated, which could provide another option for the management of Reactive Power by enabling employment of participants to produce or absorb Reactive Power as necessary, instead of utilising conventional means of mitigating the effect of Reactive Power (i.e. increased transmission capacity and/or Reactive Power compensation) whose construction would have a negative environmental impact.

Applicable BSC Objective (c)

- Reactive Power would be allocated more appropriately and accurately to the Party actually responsible for them (or the MSID they should logically be assigned to), and therefore DUoS charges relating to Reactive Power will be more accurate and targeted correctly;
- More accurate DUoS charges relating to Reactive Power, and more correct targeting of charges to Parties actually responsible for Reactive Power flows, will facilitate competition;
- More appropriate allocation and metering of Reactive Power would facilitate potential creation of a competitive market in trading Reactive Power volumes;
- More appropriate allocation and metering of Reactive Power would facilitate a market for ancillary services for Exemptable Generating Plant, removing a potential barrier to the creation of new plant if Suppliers were reluctant to provide services due to inflated DUoS bills caused by inappropriate allocation of Reactive Power;
- The additional, more accurate data available would allow LDSOs not currently charging for Reactive Power to do so, and would facilitate competition in Distribution System operation to the benefit of Generators and Suppliers, thereby promoting competition among these participants and encouraging entry into the market; and
- Facilitate competition between Import Suppliers to Exemptable Generating Plant, as currently plant of this type are potentially restricted in their ability to switch Import Supplier due to reluctance by Suppliers to risk exposure to inflated DUoS bills.

The Panel agreed that the Proposed Modification would have a neutral impact on Applicable BSC Objectives (a) and (d).

The primary benefits of the Proposed Modification are against Objective (c); the anticipated improvement of facilitation of Objective (b) being less substantial.

Provisional recommendation to the Authority

The Panel therefore agreed a **UNANIMOUS** provisional recommendation to the Authority that:

- The Proposed Modification **SHOULD** be made.

6.1.3 Implementation Date

The Panel agreed with the Modification Group's recommendation regarding the Implementation Date.

The Panel noted the considerations of the Group regarding the structure of the P224 Implementation Date (and associated decision cut-off date) following the recent ruling that the Authority is unable to make decisions on approval of Proposed Modifications after the decision cut-off dates specified in Modification Reports (see Ofgem's [Open Letter](#) of 17 July 2008 regarding the zonal transmission losses Modification Proposals). The Group concluded that it was not necessary to amend the structure of the recommended P224 Implementation Date in view of this, because the change did not appear to be contentious and it seemed the lead time allowed for an Authority decision would be sufficient; the Panel was comfortable with the Group's assessment of this matter.

6.1.4 Legal Text

The Panel reviewed the draft text and agreed that it addresses the defect identified by the Modification Proposal.

6.2 Results of Report Phase Consultation

[This section to be completed following the Report Phase consultation]

6.3 Panel's Consideration of Draft Modification Report

[This section to be completed following the Panel meeting at which the draft Modification Report and Report Phase consultation responses are considered]

6.4 Panel's Final Recommendation to the Authority

[This section to be completed following the Panel meeting at which the draft Modification Report and Report Phase consultation responses are considered]

7 TERMS USED IN THIS DOCUMENT

Other acronyms and defined terms take the meanings defined in Section X of the Code.

Acronym/Term	Definition
CDCA	Central Data Collection Agent
CVA	Central Volume Allocation
DUoS	Distribution Use of System
Exemptable Generating Plant	Generating plant that are exempt from the requirement to hold an electricity licence to operate because their export capability is below a threshold (100MW in England and Wales)
kVAr	Kilo Volt Amp Reactive – unit of Reactive Power
kVArh	Kilo Volt Amp Reactive hour – unit used for Reactive Power charging
LDSO	Licensed Distribution System Operators
LEG	Licence Exempt Generator
MPAN	Metering Point Administration Number - a unique number relating to a Metering Point under the MRA (SVA equivalent of MSID)

MRA	Master Registration Agreement
MSA	Mandatory Services Agreement
MSID	Metering System Identifier – used for CVA Metering System (CVA equivalent of MPAN)
SVA	Supplier Volume Allocation
Reactive Power Charges	LDSO charge for Party operation (i.e. Supply or Generation) that results in associated Reactive Power in excess of an agreed value (billed in units of kVArh)
Supply Capacity Charges (or Demand Capacity Charges)	LDSO charge for Party operation (i.e. Supply or Generation) that results in the Party exceeding their maximum capacity for power distribution (billed in units of kVA) (NB - Reactive Power occupies distribution capacity (in the same way as Active Power) so contributes to a Party potentially exceeding agreed capacity)

8 DOCUMENT CONTROL

8.1 Authorities

Version	Date	Author	Reviewer	Reason for Review
0.1	15/08/08	Dean Riddell	David Jones	For technical review
0.2	18/08/08	Dean Riddell	BSC Parties and other interested parties	For consultation
0.3				For technical review
0.4				For quality review
0.5		Change Delivery	BSC Panel	For Panel decision
1.0		BSC Panel		For Authority decision

8.2 References

Ref.	Document Title	Owner	Issue Date
1	Business Council for Sustainable Energy UK document	UKBCSE	May 2008
2	REA/BERR Future Energy System slides	REA/BERR	19 June 2008
3	Energy Networks Association spreadsheet showing DUoS tariffs at April 2008 (GB DNO DUoS and G-DUoS Final tariff tables April 2008.xls).	ENA	April 2008
4	Ofgem Open Letter regarding zonal transmission losses Modification Proposals	Ofgem	17 July 2008

APPENDIX 1: LEGAL TEXT

Draft legal text for the Proposed Modification is attached as a separate document, Attachment 1.

Plain-English explanation of draft P224 legal text:

- K1.1.4 - the terms Import and Export are retained, but new paragraph (f) specifies that these terms include Active Export and Active Export Related Reactive Energy and Active Import and Active Import Related Reactive Energy.
- New paragraph K1.2.6 - specifies that Active Export Related Reactive Energy and Active Import Related Reactive Energy should be measured separately - this is what means that the P224 solution, as detailed in the CoPs, must be used.
- New paragraph K1.2.7 - specifies where the Active Export Related Reactive Energy and Active Import Related Reactive Energy do not need to be measured separately, and why - i.e. cases where the P224 solution does not need to be used. These are:
 - (a) All NHH sites;
 - (b) All CVA-only sites;
 - (c) Non-mandatory HH sites where the relevant CoP specifies a different approach in relation to Reactive Energy; and
 - (d) Sites where the version of the relevant CoP (or Metering Dispensation) pre-dates the implementation of P224.

This means the P224 solution is applied to all HH Settled sites (even if they have elected to Settle on a HH basis) that are registered wholly or partly in SVA, unless they are subject to specific alternative arrangements under (c) or pre-date P224 implementation.

- L1.1 - makes the requirement more specific and directs to the requirements in K1.2.6.
- X-1 - introduces the terms Active Export, Active Import, Active Export Related Reactive Energy and Active Import Related Reactive Energy, and expands the definition of Reactive Energy to specify that it comprises Active Export Related Reactive Energy and Active Import Related Reactive Energy.

APPENDIX 2: PROCESS FOLLOWED

Copies of all documents referred to in the table below can be found on the BSC Website at: <http://www.elexon.co.uk/changeimplementation/ModificationProcess/ModificationDocumentation/modProposalView.aspx?propID=248>.

Date	Event
28/04/08	Modification Proposal raised by E.ON UK plc
08/05/08	IWA presented to the Panel
20/05/08	First Assessment Procedure Modification Group meeting held
28/05/08	Second Assessment Procedure Modification Group meeting held
06/06/08	Requirements Specification issued for BSC Agent impact assessment
06/06/08	Request for Party/Party Agent impact assessments request issued
06/06/08	Request for Transmission Company analysis issued

Date	Event
06/06/08	Request for BSCCo impact assessment issued
10/06/08	BSC Agent impact assessment response returned
18/06/08	Party/Party Agent impact assessment responses returned
18/06/08	Transmission Company analysis returned
18/06/08	BSCCo impact assessment returned
23/06/08	Third Assessment Procedure Modification Group meeting held
03/07/08	Assessment Procedure consultation issued
17/07/08	Assessment Procedure consultation responses returned
21/07/08	Fourth Assessment Procedure Modification Group meeting held
14/08/08	Assessment Report presented to the Panel
18/08/08	Draft Modification Report issued for industry consultation
02/09/08	Report Phase consultation responses returned
11/09/08	Draft Modification Report presented to the Panel
	Final Modification Report issued to the Authority for decision

ESTIMATED COSTS OF PROGRESSING MODIFICATION PROPOSAL ¹²

Meeting Cost	£2,000
Legal/Expert Cost	£0
Impact Assessment Cost	£5,000
ELEXON Resource	68 man days £14,405

These estimated costs have not changed from those provided in the IWA.

APPENDIX 3: ASSESSMENT REPORT

The P224 Assessment Report is attached as a separate document, Attachment 2.

For the purposes of the Report Phase consultation and the Panel's consideration of the draft Modification Report, the P224 Assessment Report can be found on the BSC Website at: <http://www.elexon.co.uk/changeimplementation/ModificationProcess/modificationdocumentation/modProposalView.aspx?propID=248>.

¹² Clarification of the meanings of the cost terms in this appendix can be found on the BSC Website at the following link: http://www.elexon.co.uk/documents/Change_and_Implementation/Modifications_Process_-_Related_Documents/Clarification_of_Costs_in_Modification_Procedure_Reports.pdf

The Assessment Report includes:

- The conclusions of the Modification Group regarding the areas set out in the P224 Terms of Reference;
- Details of the Group's membership;
- The full results of the Assessment Procedure impact assessment; and
- Full copies of all responses to the Assessment Procedure consultation.

APPENDIX 4: REPORT PHASE CONSULTATION RESPONSES

[To be attached following Report Phase consultation]