

NETA Central Services

ISRA System Management Guide

Synopsis	The document provides information that will enable the ISRA System Manager to support system operations.
Client	ELEXON Limited
Version	27.20
Effective Date	26 February 2015 <u>05 November 2015</u>
Status	Draft <u>Final</u>
Prepared by	Cognizant
Approved by (Cognizant)	Project Manager

Copyright

The copyright and other intellectual property rights in this document are vested in ELEXON. These materials are made available to participants in the GB electricity industry to review and copy for the sole purpose of their participation in the electricity industry. All other commercial use is prohibited including downloading, copying, distributing, modifying, transmitting, publishing, selling or creating derivative works (in whatever format) from this document or in other cases use for personal academic or other non-commercial purposes. All copyright and other proprietary notices contained in the document must be retained on any copy you make.

All other rights of the copyright owner not expressly dealt with above are reserved.

No representation, warranty or guarantee is made that the information in this document is accurate or complete. While care is taken in the collection and provision of this information, ELEXON Limited shall not be liable for any errors, omissions, misstatements or mistakes in any information or damages resulting from the use of this information or action taken in reliance on it.

Table Of Contents

1	Introduction.....	95
1.1	Purpose	95
1.2	Scope.....	95
1.3	Structure of Document.....	95
1.4	Amendment History.....	106
1.5	Summary of Changes.....	139
1.6	Changes Forecast	139
1.7	References.....	139
2	Overview of the System	1612
2.1	ISRA/SVAA Differences.....	1612
2.2	Users of the System	1612
2.3	Data Interfaces	1612
3	System Structure.....	1915
3.1	Data Loader (IDL) Subsystem.....	1915
3.2	Standing Data Maintenance (ISY) Subsystem	2016
3.3	Daily Profile Production (IDP) Subsystem.....	2016
3.4	Run Settlement (IRS/INS) Subsystem.....	2147
3.5	Report Production (IRP) Subsystem.....	2147
3.6	Archive and Restore (IAR) Subsystem.....	2218
3.7	File Receipt (CFR) Subsystem	2319
3.8	Scheduler (CSC) Subsystem.....	2420
3.9	Logging (CLG) Subsystem.....	2420
3.10	User Administration (IUA) Subsystem	2521
3.11	File Sender (CFS) Subsystem.....	2521
3.12	Report Display (CRP) Subsystem	2521
4	Application Environment.....	2723
4.1	Hardware.....	2723
4.2	Software	2824
4.3	Configuration Management Procedures	2925
4.4	External Support	3026
4.5	Schedule of Activities.....	3127
5	Database Organisation	3228
5.1	Database Tables	3228
5.2	Timestamps.....	3531
5.3	Domains	3531
5.4	Database Sizing	3834
5.5	Physical Organisation (Tablespaces/Files).....	4541
5.6	Oracle Parameters	4541
5.7	Some Considerations for Performance Optimisation	4642
6	System Organisation.....	4844
6.1	Directory Structure	4844
6.2	File Names	5046
6.3	File Locations	5349
6.4	Flat File Location.....	5652
6.5	File Sizing.....	5854
6.6	Environment Variables	6055

6.7	Batch Queues	6157
7	System Parameters	6258
8	User Accounts, Privileges and Security	6460
8.1	Server Operating System	6460
8.2	Oracle Database Tables	6460
8.3	Oracle Forms Access	6561
8.4	Password Management Through Oracle Profile	6662
8.5	Maintain User	6662
8.6	Breaches of Security	6662
9	Auditing	6763
9.1	Audit Database Tables	7066
9.2	Audit Log Files	7066
9.3	Audit Appointment Standing Data Changes	7470
10	Starting Up and Shutting Down the System.....	7672
10.1	Starting the System	7672
10.2	Shutting Down the System	7773
11	Monitoring the System	7874
11.1	Operator and Error Logs	7874
11.2	Scheduler Logs	8177
11.3	Exception Reports.....	8177
11.4	Data Load Standing Data Update Reports	8177
11.5	Audit Logs and Reports	8177
11.6	Directories.....	8278
12	Archiving	8379
12.1	Backing Up Data to Off-line Media	8379
12.2	Removing Backed Up Database and File Data.....	8379
12.3	Restoring Database Data.....	8682
12.4	Restoring Data Files	8682
13	Backup and Recovery.....	8783
13.1	Guidelines on Backup Policy.....	8783
13.2	Checkpointing.....	8884
13.3	Daily Off-line Backups of the ISRA Database.....	8884
13.4	Daily Backups of the ISRA File Store.....	8884
13.5	Restoration for Recovery.....	8884
14	System Management of Application Server	9187
14.1	Remove the Old Report Files	9187
Appendix A	Application Error Messages	9288
A.1	Restore Exception Report Messages	9288
A.2	Error Log Messages	9288
A.3	Data Load Standing Data Update Report Messages.....	111405
1	Introduction.....	5
1.1	Purpose	5
1.2	Scope.....	5
1.3	Structure of Document.....	5

1.4	Amendment History.....	6
1.5	Summary of Changes.....	9
1.6	Changes Forecast.....	9
1.7	References.....	9
2	Overview of the System.....	12
2.1	ISRA/SVAA Differences.....	12
2.2	Users of the System.....	12
2.3	Data Interfaces.....	12
3	System Structure.....	15
3.1	Data Loader (IDL) Subsystem.....	15
3.2	Standing Data Maintenance (ISY) Subsystem.....	16
3.3	Daily Profile Production (IDP) Subsystem.....	16
3.4	Run Settlement (IRS/INS) Subsystem.....	17
3.5	Report Production (IRP) Subsystem.....	17
3.6	Archive and Restore (IAR) Subsystem.....	18
3.7	File Receipt (CFR) Subsystem.....	19
3.8	Scheduler (CSC) Subsystem.....	20
3.9	Logging (CLG) Subsystem.....	20
3.10	User Administration (IUA) Subsystem.....	21
3.11	File Sender (CFS) Subsystem.....	21
3.12	Report Display (CRP) Subsystem.....	21
4	Application Environment.....	23
4.1	Hardware.....	23
4.2	Software.....	24
4.3	Configuration Management Procedures.....	25
4.4	External Support.....	26
4.5	Schedule of Activities.....	27
5	Database Organisation.....	28
5.1	Database Tables.....	28
5.2	Timestamps.....	31
5.3	Domains.....	31
5.4	Database Sizing.....	34
5.5	Physical Organisation (Tablespaces/Files).....	41
5.6	Oracle Parameters.....	41
5.7	Some Considerations for Performance Optimisation.....	42
6	System Organisation.....	44
6.1	Directory Structure.....	44
6.2	File Names.....	46
6.3	File Locations.....	48
6.4	Flat File Location.....	52
6.5	File Sizing.....	53
6.6	Environment Variables.....	55
6.7	Batch Queues.....	56
7	System Parameters.....	57
8	User Accounts, Privileges and Security.....	59
8.1	Server Operating System.....	59
8.2	Oracle Database Tables.....	59

8.3	Oracle Forms Access	60
8.4	Password Management Through Oracle Profile	61
8.5	Maintain User	61
8.6	Breaches of Security	61
9	Auditing	62
9.1	Audit Database Tables	65
9.2	Audit Log Files	65
9.3	Audit Appointment Standing Data Changes	69
10	Starting Up and Shutting Down the System	71
10.1	Starting the System	71
10.2	Shutting Down the System	72
11	Monitoring the System	73
11.1	Operator and Error Logs	73
11.2	Scheduler Logs	76
11.3	Exception Reports	76
11.4	Data Load Standing Data Update Reports	76
11.5	Audit Logs and Reports	76
11.6	Directories	77
12	Archiving	78
12.1	Backing Up Data to Off line Media	78
12.2	Removing Backed Up Database and File Data	78
12.3	Restoring Database Data	81
12.4	Restoring Data Files	81
13	Backup and Recovery	82
13.1	Guidelines on Backup Policy	82
13.2	Checkpointing	83
13.3	Daily Off line Backups of the ISRA Database	83
13.4	Daily Backups of the ISRA File Store	83
13.5	Restoration for Recovery	83
14	System Management of Application Server	86
14.1	Remove the Old Report Files	86
Appendix A	Application Error Messages	87
A.1	Restore Exception Report Messages	87
A.2	Error Log Messages	87
A.3	Data Load Standing Data Update Report Messages	103
1	Introduction	5
1.1	Purpose	5
1.2	Scope	5
1.3	Structure of Document	5
1.4	Amendment History	6
1.5	Summary of Changes	9
1.6	Changes Forecast	9
1.7	References	9
2	Overview of the System	12
2.1	ISRA/SVAA Differences	12

2.2	Users of the System	12
2.3	Data Interfaces	12
3	System Structure.....	15
3.1	Data Loader (IDL) Subsystem	15
3.2	Standing Data Maintenance (ISY) Subsystem	16
3.3	Daily Profile Production (IDP) Subsystem	16
3.4	Run Settlement (IRS/INS) Subsystem	17
3.5	Report Production (IRP) Subsystem	17
3.6	Archive and Restore (IAR) Subsystem	18
3.7	File Receipt (CFR) Subsystem	19
3.8	Scheduler (CSC) Subsystem	20
3.9	Logging (CLG) Subsystem	20
3.10	User Administration (IUA) Subsystem	21
3.11	File Sender (CFS) Subsystem	21
3.12	Report Display (CRP) Subsystem	21
4	Application Environment.....	23
4.1	Hardware	23
4.2	Software	24
4.3	Configuration Management Procedures	25
4.4	External Support	26
4.5	Schedule of Activities	27
5	Database Organisation	28
5.1	Database Tables	28
5.2	Timestamps	31
5.3	Domains	31
5.4	Database Sizing	34
5.5	Physical Organisation (Tablespaces/Files)	41
5.6	Oracle Parameters	41
5.7	Some Considerations for Performance Optimisation	42
6	System Organisation.....	44
6.1	Directory Structure	44
6.2	File Names	46
6.3	File Locations	48
6.4	Flat File Location	51
6.5	File Sizing	52
6.6	Environment Variables	53
6.7	Batch Queues	55
7	System Parameters	56
8	User Accounts, Privileges and Security	58
8.1	Server Operating System	58
8.2	Oracle Database Tables	58
8.3	Oracle Forms Access	59
8.4	Password Management Through Oracle Profile	60
8.5	Maintain User	60
8.6	Breaches of Security	60
9	Auditing	61
9.1	Audit Database Tables	64

9.2	Audit Log Files	64
9.3	Audit Appointment Standing Data Changes	68
10	Starting Up and Shutting Down the System.....	70
10.1	Starting the System	70
10.2	Shutting Down the System	71
11	Monitoring the System	72
11.1	Operator and Error Logs	72
11.2	Scheduler Logs	75
11.3	Exception Reports.....	75
11.4	Data Load Standing Data Update Reports.....	75
11.5	Audit Logs and Reports	75
11.6	Directories.....	76
12	Archiving	77
12.1	Backing Up Data to Off line Media	77
12.2	Removing Backed Up Database and File Data.....	77
12.3	Restoring Database Data.....	80
12.4	Restoring Data Files	80
13	Backup and Recovery.....	81
13.1	Guidelines on Backup Policy.....	81
13.2	Checkpointing.....	82
13.3	Daily Off line Backups of the ISRA Database.....	82
13.4	Daily Backups of the ISRA File Store.....	82
13.5	Restoration for Recovery	82
14	System Management of Application Server.....	85
14.1	Remove the Old Report Files	85
Appendix A	Application Error Messages	86
A.1	Restore Exception Report Messages	86
A.2	Error Log Messages.....	86
A.3	Data Load Standing Data Update Report Messages.....	101

1 Introduction

This document is the System Management Guide for the ISRA application software developed for ELEXON.

1.1 Purpose

The purpose of this System Management Guide is to provide information that will enable the ISRA System Manager to support system operation.

1.2 Scope

The ISRA application software is the central component of an operational system. The recipient organisation needs to build operational procedures around the application software that will meet the requirements of its users and complement other aspects of the organisation's operational environment. Organisations need to comply with Agreed Procedures and Service Lines.

The scope of this guide covers the system management aspects of the ISRA application software, such as system structure; directories and file names; database organisation; archive and restoration of data; audit logs and guidelines on backup and recovery. Detail pertaining to hardware and third party software is included only where necessary to support the description of the ISRA application software.

For operational aspects of the ISRA application software, refer to the ISRA Operations Guide.

For details of installation of the ISRA application software, refer to the ISRA Installation Guide.

Comments on the completeness and accuracy of this guide are welcome. A Comment Form is contained at the back of this guide.

1.3 Structure of Document

The remainder of this document consists of the following sections:

- Section 2 gives an overview of the ISRA system;
- Section 3 describes the system structure in terms of its subsystems;
- Section 4 outlines the hardware and software environment, configuration management, external support for the application software, and outlines tasks that should be included in a schedule for supporting the application environment;
- Section 5 shows the organisation of the ISRA database;
- Section 6 describes the organisation of the ISRA system;
- Section 7 describes the system parameters used by the system;
- Section 8 provides information on system security;
- Section 9 describes the functionality provided for auditing;
- Section 10 describes how to start up and shut down the system;
- Section 11 describes the facilities available for monitoring the system;
- Section 12 discusses archive and restore facilities;
- Section 13 outlines backup and recovery functionality.

Appendices to this document are as follows:

- Appendix A lists Application error messages.

1.4 Amendment History

Version	Details
0.901	First draft to client.
0.902	Addressing highest priority comments.
0.903	Addressing severity 1, 2 and most severity 3 and 9 comments.
0.990	Addressing additional and outstanding Pool comments.
1.000	Authorised version
1.001	Incorporates updates to software version numbers only. This version is consistent with Release 1.2 of the ISRA Software.
1.500	Incorporates review changes from v1.001 internal review.
2.000	Incorporates review changes from v1.500 external review. This version is consistent with Release 1.3 of the ISRA Software.
2.401	Draft for internal review, incorporating Release 2 changes.
2.490	Includes internal review comments, Draft for review by Pool, incorporating Release 2 changes.
2.500	Includes Pool review comments on Release 2 changes.
2.990	Merger of version 2.000 and version 2.500. Change bars show changes since version 2.000. Includes amendments for LCR077 and OR 2622 (LCR077 FAT OR/16). Issued to Pool for review.
3.000	Includes Pool comments. Includes OR 2588 (Pool defect 1538). Includes OR 2589 (Pool defect 1539). This version is consistent with Release 2.0 of the ISRA Software.
3.001	Includes Ors 2609, 2753.
3.002	Draft version for internal review, incorporating changes for TA2000 development. Includes following Change Requests: Package 1: LCRA113 (SIR R577) LCRA125 (SIR R669) LCRA131/3 (SIR R918) and Clarification: 001ldr30 (v3.0). Package 2 / MDD: LCRA85/2 (SIR R293) LCRA88/2 (SIR R574) LCRA104 (SIR R294) LCRA111/2 (SIR R887) LCRA137 (SIR R887) LCRA124/2 (SIR R295) LCRA126 (SIR R728) LCRA128/1 (SIR R1116) LCRA128/3 and Clarification LCRA136 (SIR R1116) and Clarification: 002ldr50.
3.990	Incorporating internal review comments. Issued to Pool for review.
3.991	Includes Pool review comments for 3.990. Includes amendments for OR 2756.
3.992	Update to incorporate Pool review comments for 3.991. Includes amendments for OR 2776.

Version	Details
4.000	Authorised version consistent with releases 4.0.0/5.0.0
4.990	Removed references to release 4 functionality Issued to Pool for review.
5.000	Authorised version
5.001	Incorporating LCR150, LCR151 and LCR155 (SIR R2215)
5.990	Incorporating internal review comments. Issued to Pool for external review
5.991	Incorporating Pool review comments
5.992	Incorporating Pool review comments
6.000	Authorised version
6.001	Incorporating LCR159, 164, 165 and 166 (SIR R2327): Multiple BM Unit support for ISRA/SVAA
6.990	Incorporating internal review comments. Issued to the Pool for review.
6.991	Ensured consistency with LCR166
6.992	Incorporating Pool review comment (update to Copyright holder)
7.000	Authorised version incorporating Pool review comment
7.001	Incorporating LCR162/5 & LCR172 (SIR2180)
8.000	Authorised version
8.001	Change to Office 2000
8.002	Incorporating LCR174 and OR3118
8.003	Incorporating ELEXON review comments
8.004	Incorporating LCR199
8.005	Incorporating internal review comments for LCR199
8.990	Issued to ELEXON for review
8.991	Incorporating ELEXON review comments
9.001	Incorporating changes for LCR 191
9.002	Incorporating LCR202
9.003	Incorporating LCR215/3
9.990	Issued to ELEXON for review
9.991	Changes post ELEXON review
9.992	Can become 10.000 after sizing updates
10.000	Authorised version
10.001	Updated for LCR189
11.000	Authorised version
11.001	Updated for LCR203/7 (P81) Document Template Updated
11.002	Internal review re: LCR189 & P81
11.003	Updated following internal review
11.004	Updated from ELEXON's review Incorporating OR3382
12.000	Authorised version
12.001	Incorporating LCR227 Incorporating LCR218/5 (BETTA)
12.002	Updated following internal review
12.990	Issued to ELEXON for review

Version	Details
12.991	Updated from ELEXON's review Incorporating OR3429
13.000	Authorised version
14.000	Updated document references
14.990	Updated for LCR235 (Disable the ability for a P0214 file to be loaded into SVAA)
14.991	Updated from ELEXON's review
15.000	Authorised version
15.001	Updated for changes CP850, CP892 and CP947. Issued to ELEXON for review.
15.002	Amended after feedback from ELEXON. Issued to ELEXON for review.
15.003	Amended after further feedback from ELEXON. Issued to ELEXON for review.
16.000	Authorised version
16.991	Updated for P192 NGC Name Change
16.992	Amended after feedback from ELEXON review
16.993	Updated to include ELEXON review comments and changes for: CP929 Removal of performance reports from SVAA; CP1001 Improvements to facilitate reporting and improve usability; CP1093 Failure of suppliers to submit valid standing data relationships.
16.994	Address internal review comments
17.000	Authorised version
17.001	Draft for Internal review for Nov. 06 release, including Oracle Upgrade to 10g database.
17.002	Further changes for November 06 release, OR3661/HD061732
17.990	Version for ELEXON review
17.991	Updated from ELEXON review comments
18.000	Authorised version
18.900	Draft for Internal review BSC Systems Technical Refresh : Port of SVAA to HPUX
18.990	Incorporating internal review comments; draft for ELEXON review.
18.991	Incorporating ELEXON review comments
19.000	Authorised version
19.900	Draft for Internal review : Jun 08 release: CP1209 Inclusion of MSID Counts on the GSP Group Consumption Totals Report
20.000	Authorised version
20.900	ISIS Enhancement Changes
20.901	Applied review comments
20.990	Version for ELEXON review
21.000	Authorised version
21.010	Updated document classification
21.0	Back issued for exit management
21.1	Updates made for Technology Upgrade 2011 Project
22.0	Technology Upgrade 2011: Final version
22.1	Updated for Technology Upgrade 2012

Version	Details
22.2	Incorporating ELEXON review comments
23.0	Baselined after Technology Upgrade 2012 release
24.0	Baselined after Technology Upgrade June 2013 release
25.0	Baselined after Oracle database Upgrade from 11.2.0.2 to 11.2.0.4 (June 14 release phase 1)
26.0	Baselined after June 2014 Release – EMR ¹
27.0	Baselined after Feb 2015 release – CP1418 – Updated for the additional validation when loading the SPM data files
27.1	P305 & P300 - Updated for November 2015 Release changes
27.2	Incorporated the ELEXON review comments

Table 1: Amendment History**Software Version**

This version of the ISRA System Management Guide is applicable to environment of release 9.2.0 and later versions of the ISRA application software.

1.5 Summary of Changes

Changes as indicated in the amendment history.

1.6 Changes Forecast

Agreed Change Requests will be incorporated. Feedback from ELEXON.

1.7 References

Information	Details
Title: Author:	SVA Data Catalogue Volume 1: Data interfaces ELEXON
Title: Author:	ISRA Operations Guide Cognizant
Title: Author:	ISRA Installation Guide Cognizant
Title: Author:	Logical Data Model Cognizant
Title: Author:	ISRA Technical Specification Cognizant
Title: Author:	Physical Design Common Subsystems Technical Specification Cognizant

Table 2: References**Abbreviations**

AA	Annualised Advance
AFYC	Average Fraction of Yearly Consumption
BETTA	British Electricity Transmission and Trading Arrangements
BM	Balancing Mechanism
BMUIGG	BM Unit In GSP Group

¹ EMR changes were directed by the Secretary of State on 1 August 2014

BSC	Balancing and Settlement Code
BUSTEV	BM Unit Supplier Take Energy Volume
BUSGDD	BM Unit SVA Gross Demand Data
CCC	Consumption Component Class
CDCA	Central Data Collection Agent
CTCU	Central Tele-switch Control Unit
DA	Data Aggregator
DC	Data Collector
<u>DCE</u>	<u>Demand Control Evnet</u>
<u>DCI</u>	<u>Demand Control Instruction</u>
DPP	Daily Profile Production
DRP	Data Retention Period
DUoS	Distribution Use of System
EPD	Elementary Process Description
EAC	Estimate of Annual Consumption
GMT	Greenwich Mean Time
GSP	Grid Supply Point
HH	Half-Hourly
HHDA	Half-Hourly Data Aggregator
ISR	Initial Settlement and Reconciliation
ISRA	ISR Agent
LDM	Logical Data Model
LLF	Line Loss Factor
LLFC	LLF Class
MDD	Market Domain Data
MDDA	MDD Agent
MSID	Metering System ID
NETA	New Electricity Trading Arrangements
NHH	Non-Half-Hourly
NHHDA	Non-Half-Hourly Data Aggregator
NPG	Non-Pooled Generation
PFA	Pool Funds Administrator
PPR	Profile Production Run
SAA	Settlement Administrator Agent
SPM	Supplier Purchase Matrix
SSA	Settlements System Administrator
SSC	Standard Settlement Configuration

SSR	Supplier Settlement and Reconciliation
SVA	Supplier Volume Allocation
SVAA	SVA Agent
TPR	Time Pattern Regime
TUoS	Transmission Use of System
UTC	Universal Time Clock
VMRPC	Valid Measurement Requirement Profile Class
VSCPC	Valid combinations of Settlement Configurations and Profile Classes

2 Overview of the System

2.1 ISRA/SVAA Differences

For Settlement Days from the start of the New Electricity Trading Arrangements (NETA), the ISRA system acts as the Supplier Volume Allocation Agent. The main differences between the ISR Agent and the SVA Agent are that:

- ISRA calculates not only the energy volumes attributable to a Supplier, but also the Supplier's Total Daily Purchases. SVAA does not calculate the Supplier's Total Daily Purchases. Where necessary for backwards compatibility, SVAA outputs dummy Purchase values;
- SVAA passes energy volumes attributable to BM Units for Supplier in GSP Group to Suppliers. This new Supplier BM Unit report also contains each Supplier's valid BM Units, Non-Half Hourly BM Unit Allocations and the Half Hourly consumption/generation data input into the system;
- SVAA passes energy volumes attributable to BM Units for Suppliers in GSP Groups to the Settlement Administration Agent;
- SVAA does not perform Spill Processing during the SSR Run.

A system parameter (the NETA Start Date) is used to determine whether the software is acting as the ISRA or the SVAA.

2.2 Users of the System

The ISRA system will be operated and managed by the ISR Agent appointed to run it. User roles that have been defined for the application software are as follows:

- Operator;
- Operations Supervisor;
- Standing Data Manager;
- Auditor.

2.3 Data Interfaces

Figure 1 places the ISRA system in the context of the Operational Framework. For further information about the external data interfaces, refer to section 3 of the ISRA Technical Specification.

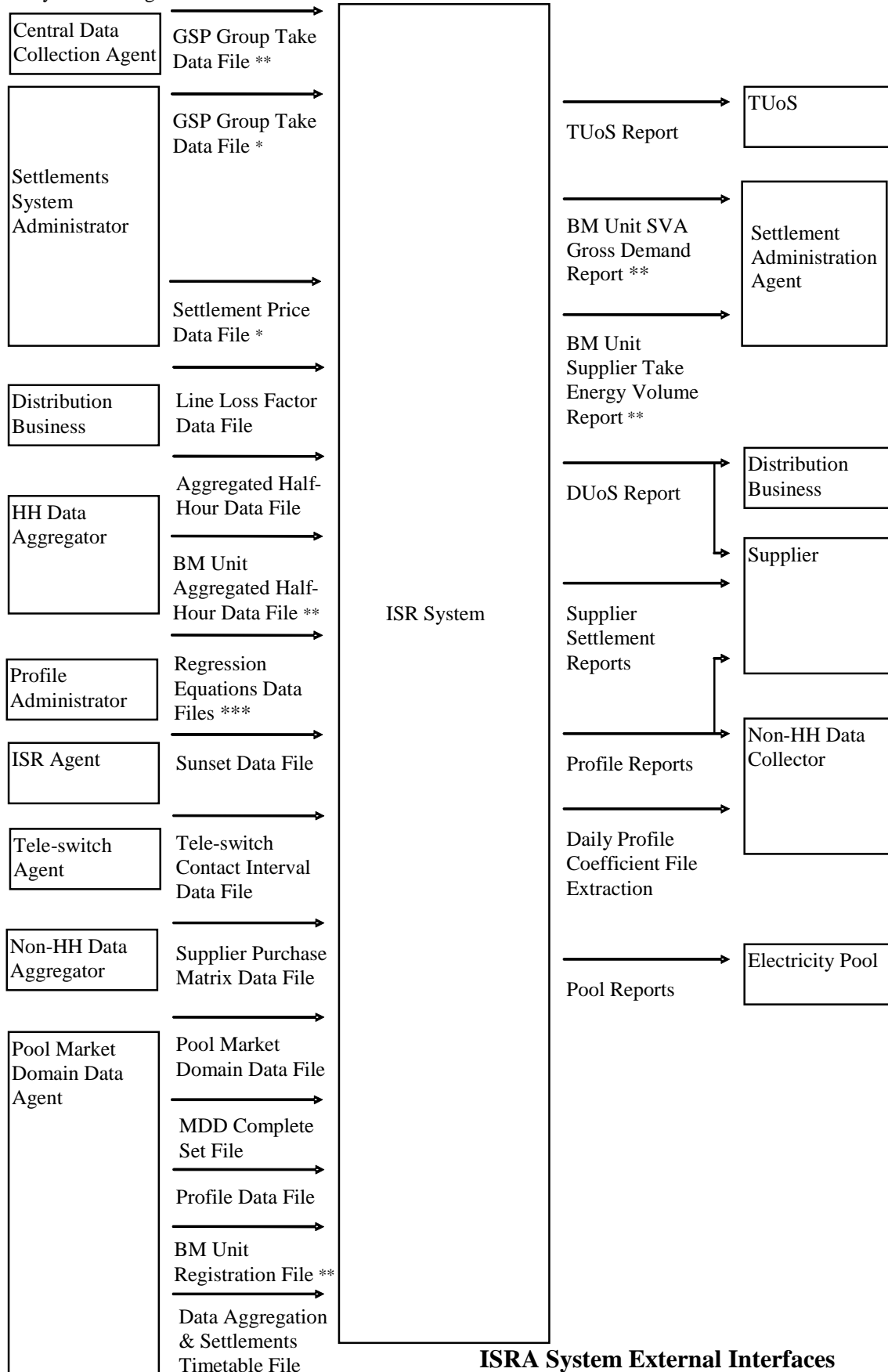

ISRA System External Interfaces

Figure 1: ISRA External Interfaces

* File only valid for Settlement Days before the start of the NETA.

** File only valid for Settlement Days from the start of the NETA.

*** This includes P0014001 (England and Wales only) and P0214001 (Scotland only) regression coefficient files².

This shows the Data Interfaces to External systems and the data that is passed across the interfaces. The detailed message and data format is given in ELEXON's Data Interface Specification 005PAT, and the Common Subsystems Technical Specification 010PZT.

² Loading of the P0214001 is disabled as a result of LCR235.

3 System Structure

This section describes the ISRA system, in terms of the main subsystems and file stores. For further information about the directory structure that supports the system, refer to section 6, and for information on inspection of process state, refer to section 10.1.

3.1 Data Loader (IDL) Subsystem

This subsystem is responsible for loading the data from received data files into the ISRA database or internal data files. The initial file receipt is handled by the File Receipt (CFR) subsystem, which then initiates the relevant ISRA data file loading process via the Scheduler (CSC) subsystem.

The receipt and loading of a file is recorded through the Operator Log via the Logger (CLG) subsystem; the content of the Settlement Configuration Data file is recorded in the Audit Log.

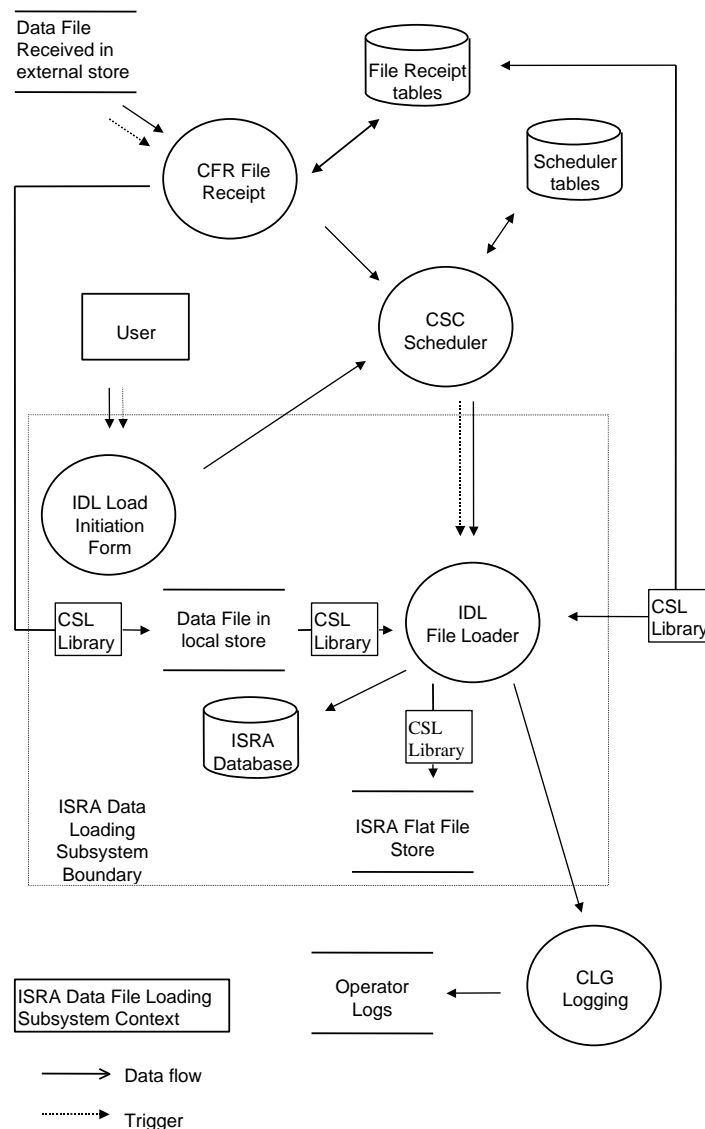

Figure 2: Data Loader Subsystem

3.2 Standing Data Maintenance (ISY) Subsystem

This subsystem consists of a suite of Oracle screen forms which provide the main user interface to the ISRA system and allow the user to maintain certain standing data for the system. For further information about these forms, refer to the ISRA Operations Guide.

3.3 Daily Profile Production (IDP) Subsystem

This subsystem is responsible for carrying out the daily profile production calculations and for producing detailed reports of the results of these calculations.

Profile production is initiated by the user via Oracle Forms and automatically generates reports on the process.

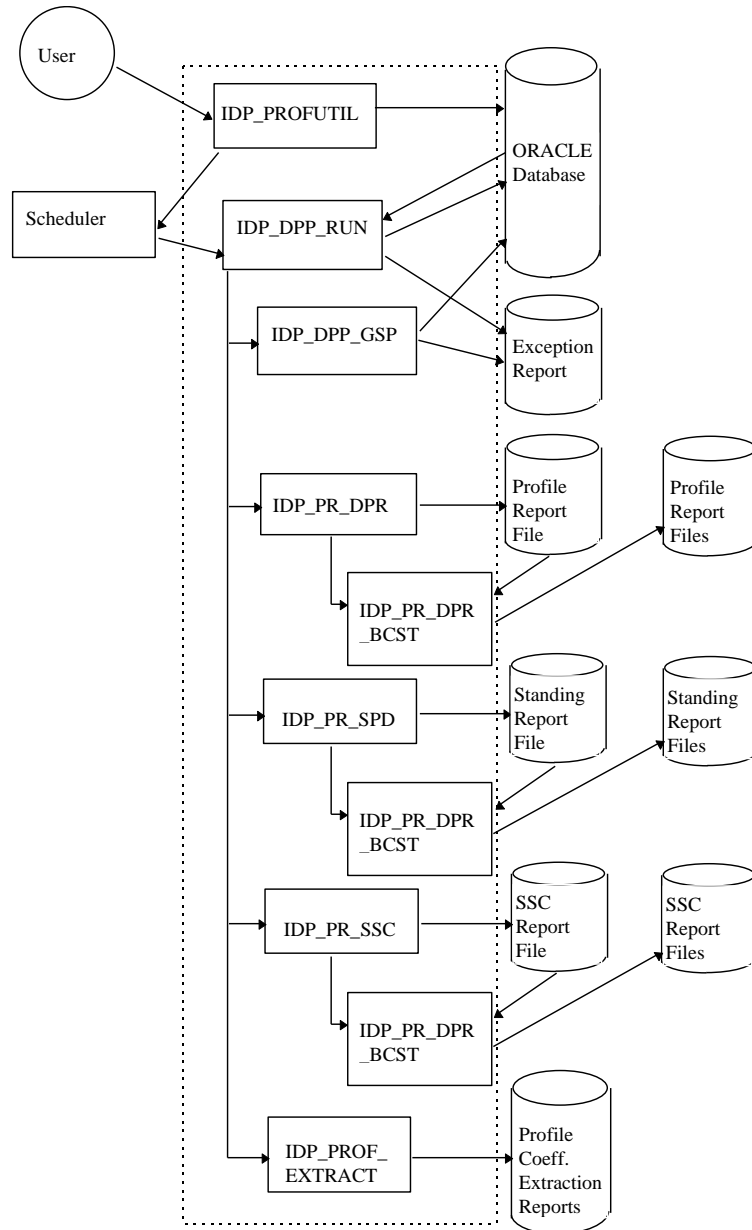

Figure 3: Profile Production Subsystem

3.4 Run Settlement (IRS/INS) Subsystem

This subsystem is responsible for carrying out settlement and reconciliation runs. For Settlement Days before the start of the NETA, the IRS subsystem is used. For Settlement Days from the start of the NETA, the INS subsystem is used.

Settlement Runs are initiated via the user interface. A number of reports are generated.

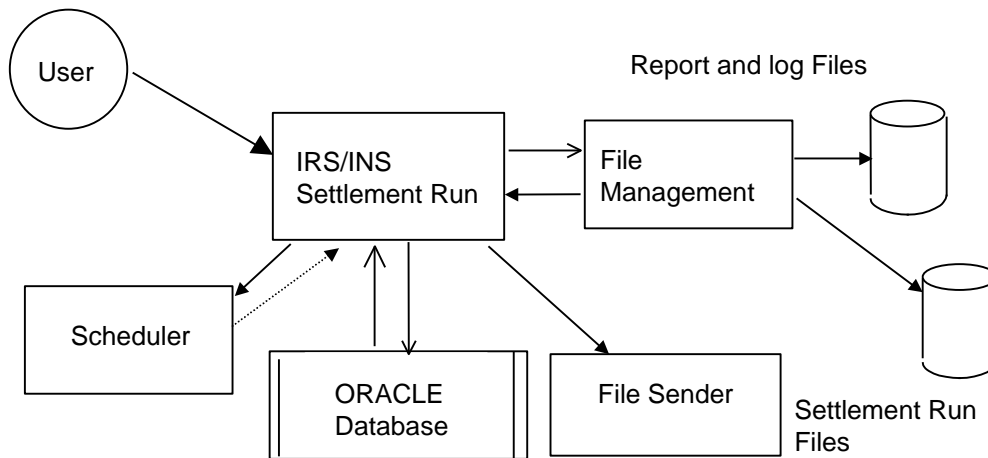

Figure 4: Run Settlement Subsystem

3.5 Report Production (IRP) Subsystem

This subsystem is responsible for the generation of reports. The reports are generated in a machine readable format. They are transmitted to third parties in this format, and can also be formatted into a human readable format by the CRP (Report Display) subsystem for printing.

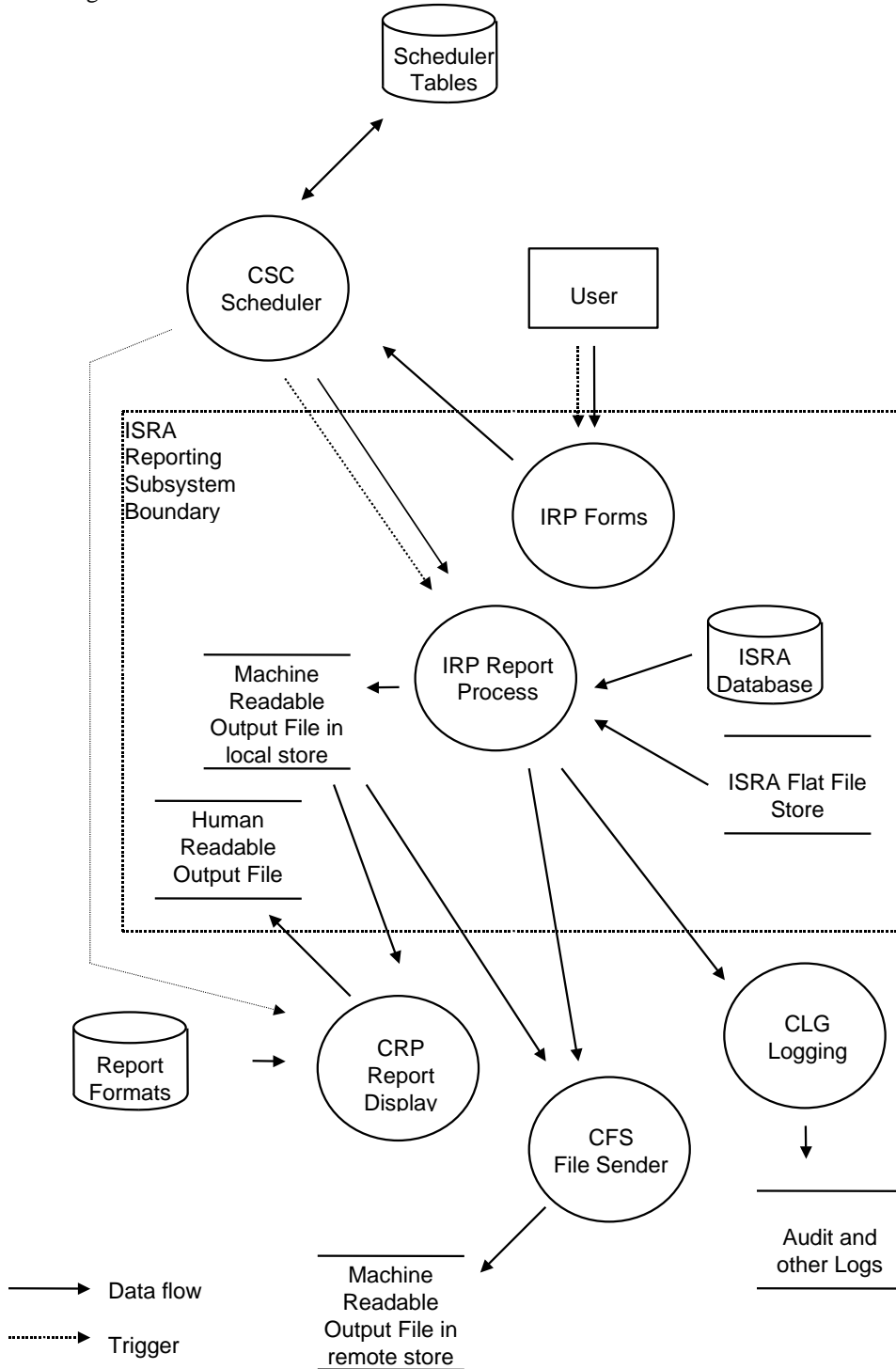

Figure 5: Report Production Subsystem

3.6 Archive and Restore (IAR) Subsystem

This subsystem is responsible for the removal of old database and file data from the system, and the selective restoring of this data from backup to a non-live database. Data deleted is Settlement Date based data for which the final reconciliation has taken place. File data are input data files, internal data files containing Settlement run and profile production run related data, and report files.

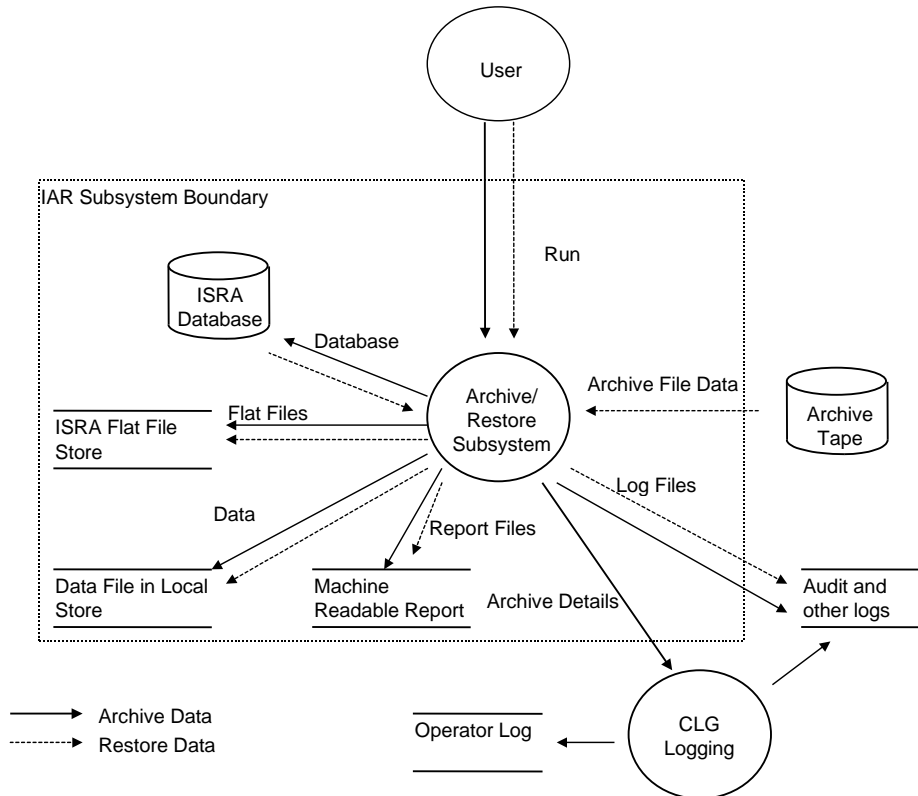

Figure 6: Archive and Restore Subsystem

3.7 File Receipt (CFR) Subsystem

The File Receipt subsystem is responsible for monitoring the arrival of new files, auditing file receipt and invoking ISRA processing activities where appropriate using the Scheduler subsystem.

A daemon process regularly looks for new external files. For each file found, a file reference record is created in the database and the file is moved to the local file store. If automatic processing has been configured, an ISRA processing activity is scheduled using the CSC Scheduler subsystem.

A process `cfr_get_tsw_cron` is scheduled in the morning to ftp Tele-Switch Contact Switching Times Files.

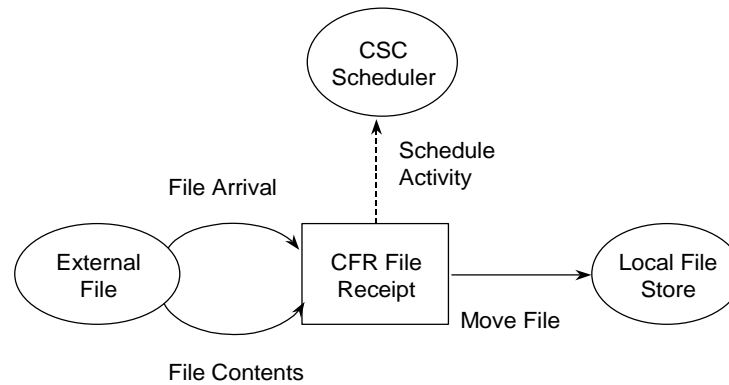

Figure 7: File Receipt Manager Subsystem

3.8 Scheduler (CSC) Subsystem

The Scheduler subsystem provides facilities to schedule and manage the execution of ISRA processes.

A queuing system is used to control server processing activities. For each queue the number of processes that may run concurrently is held in the database.

A number of processing operations are defined. Each operation has an associated executable image and is assigned to run on a particular queue. Each occurrence of a processing operation (activity) is identified by an ISRA activity id which is assigned when the activity is scheduled.

3.9 Logging (CLG) Subsystem

The CLG Logging subsystem provides facilities to write to the following log files:

- operator log - records operational events and data errors (e.g.: ‘aggregation run started’, ‘out of order instruction file received’).
- error log - records process and software errors.
- audit log - records details of changes to business data.

Data for the first two logs is written via Oracle pipes, with a daemon process to transfer this data from the pipe to each file.

Data for the audit log is temporarily held in database tables and is periodically written out to a log file.

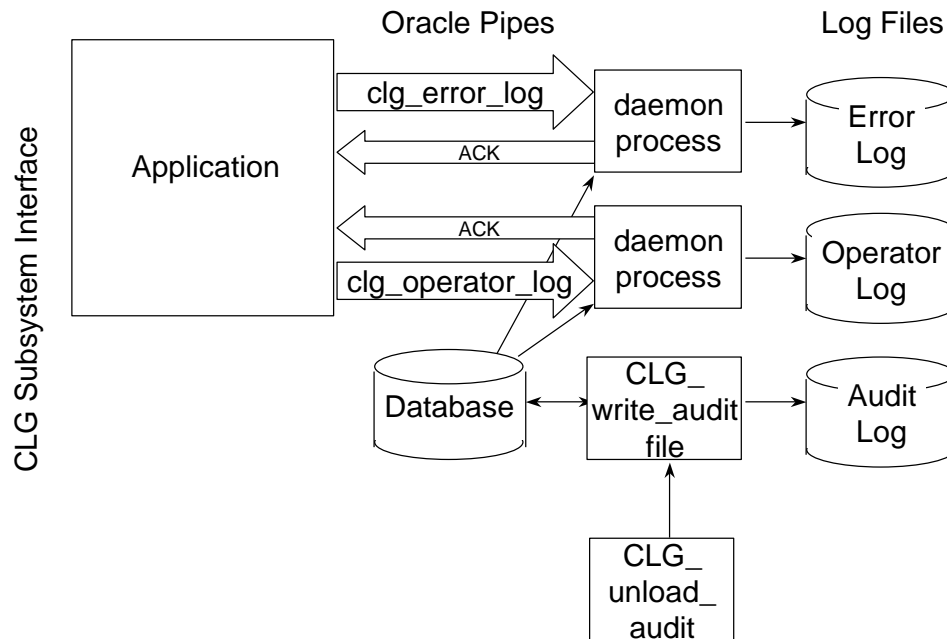

Figure 8: Logging Subsystem

3.10 User Administration (IUA) Subsystem

This subsystem provides two Oracle forms. One provides a facility for a user to change his own password. The other one provides the SVAA System Manager with a facility to manage users.

The forms work on standard Oracle database tables. No application database tables are involved, but an application view `IDB_USER_ROLES` is defined. All the work is done directly from the form. No batch process is involved.

For further information about user administration interfaces, refer to the SVAA Operations Guide.

3.11 File Sender (CFS) Subsystem

The File Sender subsystem is responsible for transferring (copying) files from the local file store to the Gateway machine. If a file transfer fails, it is automatically reattempted at a later time. The delay between attempts to send a file is defined as a system parameter; refer to section 7 for further information.

A database table is used to hold details of files to be sent.

Once a file has been transferred the database is updated accordingly, recording the 'send' time.

3.12 Report Display (CRP) Subsystem

This subsystem is concerned with the creation of human-readable reports. It operates on the internal report files produced by the system and formats these, based on information held in the database, for human readable display. The resulting output is written to a file which can be displayed at the client or sent for printing. The mechanism for selecting machine-readable reports for display is the Reports for Viewing form. For further information, refer to the ISRA Operations Guide.

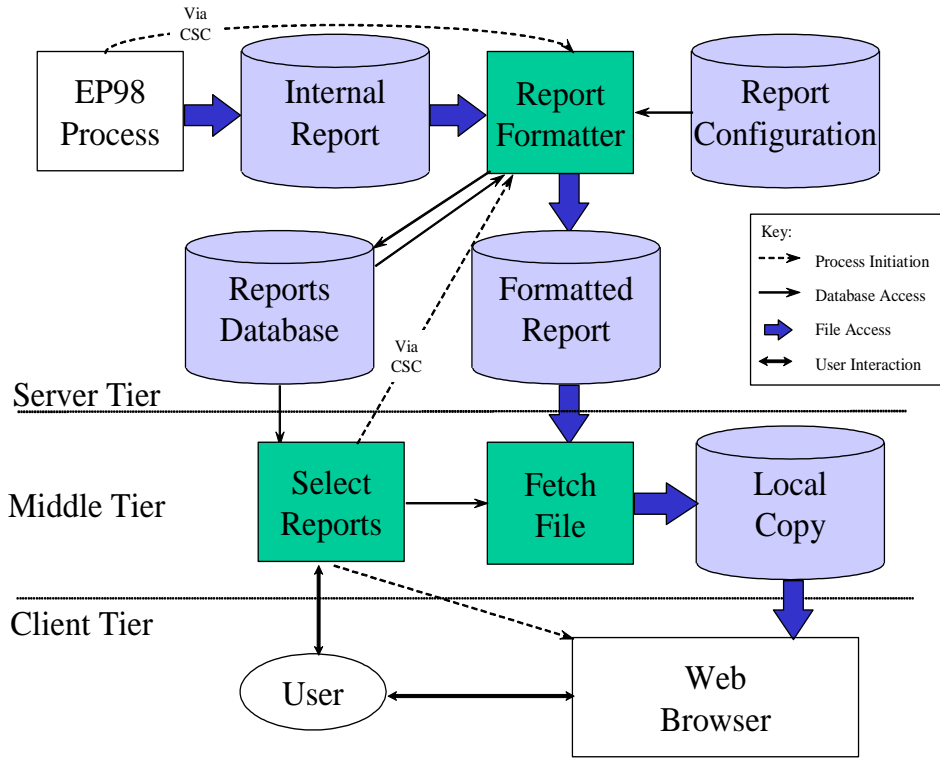

Figure 9: Report Display Subsystem

4 Application Environment

This section provides an overview of the hardware and software environment required for the ISRA system; provides information to support configuration management; outlines external support for the application software; provides an overview of the tasks that should be included in a schedule for supporting the application environment.

4.1 Hardware

The ISRA system comprises a POSIX server and a number of PC clients connected over a local area network. An overview of the physical architecture is given in Figure 10.

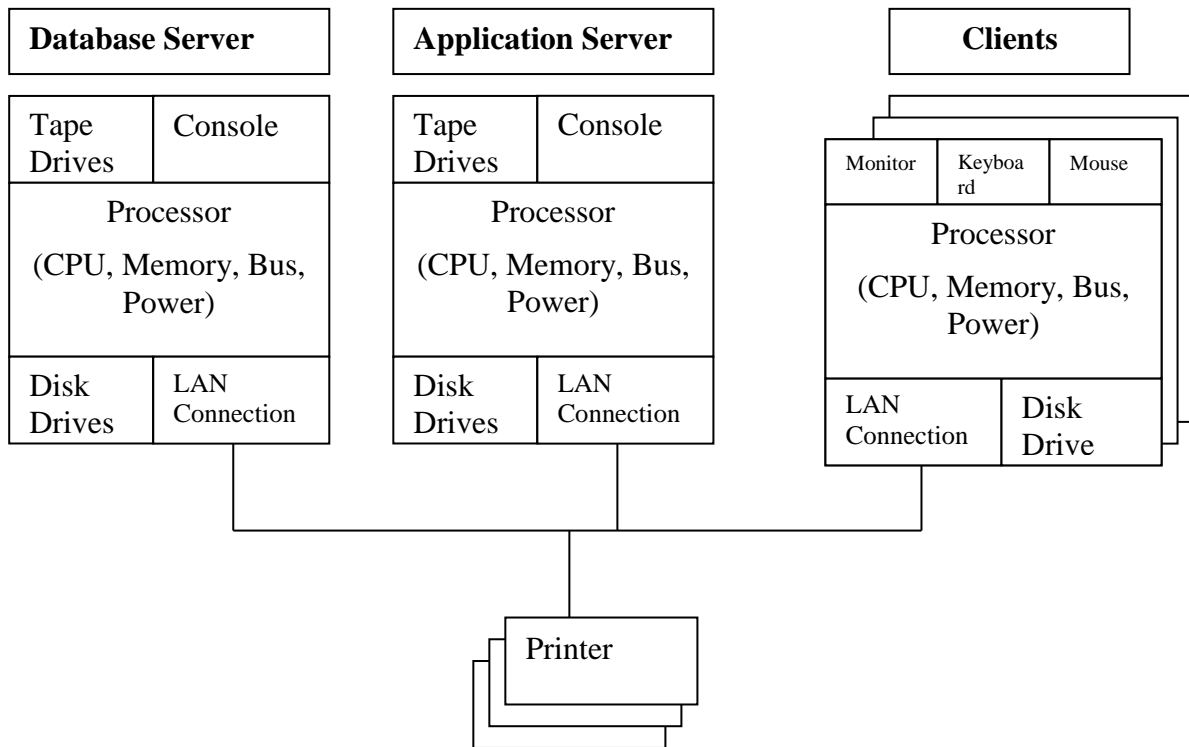

Figure 10: ISRA Physical Architecture

The detailed configuration of each component, e.g.:

- CPU speed and number;
- Memory size;
- Number and capacity of disk drives;
- Number and capacity of tape drives;
- Network line speed.

is dependent on the volumes to be handled by a particular instance of a system. However, the client monitor is expected to support a display area of at least 800 by 600 pixels.

All application code for the server is developed assuming a 64-bit architecture.

The “Gateway” is a separate system via which files are sent and received. The interface with the Gateway is assumed to be file transfer across the Local Area Network.

Note that these file transfers are both assumed to be “push” oriented, i.e.:

- For receipt the Gateway transfers the files to a directory on the server.
- For send the server transfers a copy of the files to a directory on the Gateway.

The following comprises a list of the hardware for the ISRA environment:

Server:

- POSIX-compliant server

Application Server:

- Pentium 3.4Ghz or better Processor;
- 1 GB or better Memory;
- 30 GB Disk Space.

Client:

Any that runs an Operating System and Browser supported by Oracle Application Server.

Note: Use any Browser and Operating System in Client system, which is supported by the Oracle Application Server.

4.2 Software

The ISRA system server runs an Oracle 11.2.0.4.0 database with bespoke software written in C and SQL. The Application Server runs Oracle Fusion Middleware 11G version 11.1.2.1.0 (64 bit) on Microsoft Windows 2008 R2 Server as well as Net 10 to enable Client-Server communication. An overview of the software architecture is given in Figure 11.

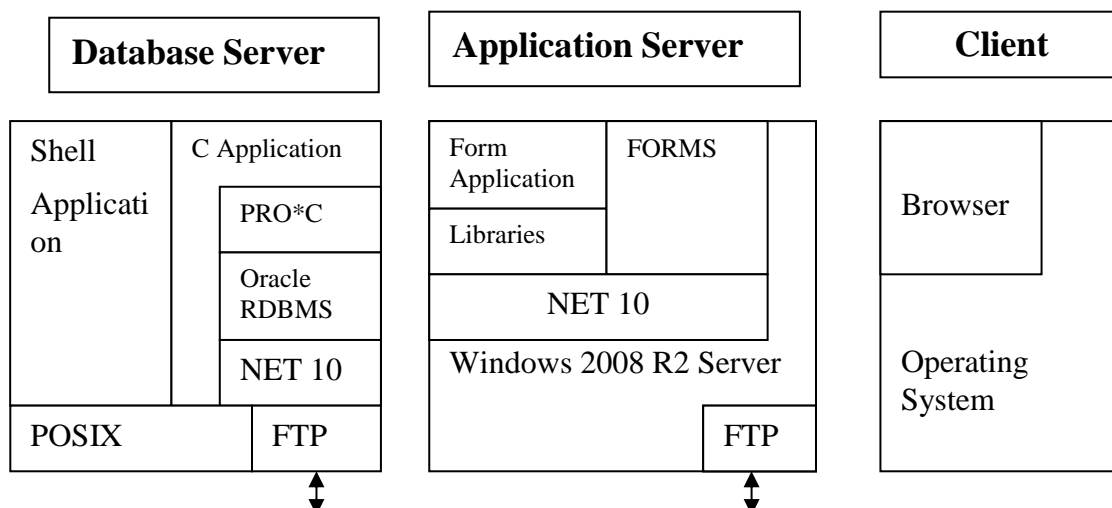

Figure 11: ISRA Software Architecture

The following table shows the software products used to support the ISRA application software.

Software Component	Host	Version
Operating System	Database Server	Compliant with POSIX standard 1003.1-1990 and POSIX 1003.1b-1993 (C language real time extension). Compliance with POSIX standard 1003.2-1992 for shell scripts. C compiler compliant with ANSI X3.159-1989
Windows 2008 R2 Server	Application Server	Service Pack 1
Oracle Server (includes PL/SQL)	Database Server	11.2.0.4.0
NET10	Application Server	10.1.4.0.2
Pro*C runtime	Database Server	11.2.0.4.0 <i>Runtime deployment is included in original Oracle/Programmer license for development</i>
Oracle Forms runtime	Client	11.1.2.1.0 (64 bit) <i>Runtime deployment is included in original Oracle/Developer license for development</i>
File Transfer Software	Server	FTP receive and send

Table 3: Application Environment – Software Products

4.3 Configuration Management Procedures

4.3.1 Introduction

During Design, Support and Development, Documentation Products and Application Software Products are kept under configuration control. Under its Agreement with ELEXON, Cognizant also continues Configuration Control of the Master copies of specified Products ('Maintained Products') until the end of the contract. This controlled framework enables Cognizant:

- a. To issue scheduled releases of maintained documentation and software to ELEXON (ELEXON is then able to distribute copies of documentation to its Agent or Pool members);
- b. To issue corrections to faults to ELEXON;
- c. To issue a release of software to an Agent or Pool member, under specific direction of the ELEXON;
- d. To hand over control of Maintained Products to ELEXON at the end of the support contract.

The following sections summarise the Configuration Control aspects used by Cognizant, which may be of use to the Manager of the Systems at a site in determining how they could be accommodated in the prevailing standards and procedures.

4.3.2 Configuration Tool

Cognizant stores and manages software under Tortoise SVN. Use of tool:

- Prevents more than one person editing a master file at one time and keeps track of all changes made to that file;

- Allows different versions of systems to be built from the same set of source files. (When the code is built the actual lines of code that are compiled is determined by a configuration file specific to a build);
- Permits building parts of the system with a single command.

The Software Release Number also includes a specific Cognizant Software Build Number.

Defect Report numbers, Remedy, ORs and SFRs: To track exceptions use is made of several numbering systems operating in parallel.

In the case of exceptions reported externally to Cognizant:

- When the exception is confirmed to be a software fault an Incident number is raised which will be used to track the changes to the ISRA, NHHDA or EAC/AA Deliverables.
- Any associated change to the software is labelled and tracked by Cognizant's SVN Configuration Management tool.

The Release Notes associated with a software release give the Incident Number (where relevant) for changes made to the controlled software.

4.3.3 Compatibility of Deliverable Products

The System Manager should be aware of a number of dependencies between the Deliverable Products. These are summarised below:

- a. Software: Software source and object are issued as a matching set and in general must not be mixed with software from previous releases. In particular Server software must be used with the matching Version number of Client (PC) software. It may be possible to install revised software to work with a database prepared using an earlier release of software, and in that case this will be made clear in the release notes. There may also be occasions where it is possible for an emergency defect repair (patch) to be made to a particular part of the installed software, and in that case it should be done according to the instructions delivered with the patch.
- b. Third party software products: Application Software assumes that the hardware and software environment on which the software is to be installed include the third party products at the version levels given in sections 4.1 and 4.2 above.
- c. HELP file and Operations Guide: The Microsoft WORD file for the Operations Guide is used by Cognizant to create the HELP file distributed on the Application software CD. In general, if a screen or report format is changed then the relevant page(s) of the Operations Guide will change and the HELP file will also reflect that change; the System Manager should ensure that any revised page or pages supplied are distributed at the system site when the revised software is installed.
- d. Other Product Deliverables: Where a change or defect correction applies to one of the other Maintained Deliverables, Cognizant will correct the master copy of that Deliverable. Distribution of copies of the revised Product Deliverable will depend on the support arrangements in place.

4.4 External Support

- a. **Problem with Distribution Kit:** If the site has a problem with the distribution kit - faulty media, for example - then it should contact Cognizant through BSC Service Desk.
- b. **Problem with the Software or Documentation:** If any problem is encountered with the application software or documentation then the Agent or Pool member should contact BSC Service Desk.

4.5 Schedule of Activities

The Manager of the Systems at a site should define a schedule of daily and weekly activities to maintain the system and keep it operable. This will include strategies for backup and archive, and a statement of the division of responsibilities with the database administrator. Clearly, a large part of these definitions will be site dependent, depending on such things as the actual hardware and software environment used and the existing site procedures. However, there are certain activities which are specific to the Application software and generic to UNIX; the table summarises some of these, and gives a reference to the section in this Guide on the topic:

Activity (includes checking that automatic processes have completed)	Type	Ref.
Backups of ISRA database and filestore, and keeping a log of these; resetting locks	Daily, Weekly, Monthly	13, 9.1
Archiving of data	Daily, Weekly, Monthly	12, 7
Monitoring Logs for correct operation, and clearing out old copies	Daily, Weekly	11
Maintenance of the values of System Parameters	Ad-hoc	7
Setting up/changing User Accounts	Ad-hoc	8
System Management examples: - Starting up and shutting down the System - Installing new PCs on local network, including Oracle client software and Application software - Keep records of system configuration and changes to it - Changing device ownership - Changing file ownership - Checking that available disk space is adequate (probably a daily task) - Installing new releases of software	Ad-hoc	4, 10 Installation Guide

Table 4: Schedule of Activities

5 Database Organisation

This section provides information on the ISRA database.

Refer to the ISRA Physical Design for the logical data structure and full data dictionary. The data dictionary can also be accessed on-line.

5.1 Database Tables

The ISRA database tables and views on tables are listed below, with a brief description of the data they hold. Those marked with an asterisk (*) are views.

Table or View Name	Description
Scheduled Jobs	
cdb_activity	Contains a row for every process that has been scheduled to run on the system (waiting to run, running, completed).
cdb_activity_parameter	Contains a row for each parameter for every process that has been scheduled to run on the system (waiting to run, running, completed).
cdb_activity_type	Each row details a processing activity that can be initiated via the Scheduler.
cdb_default_parameter	Contains a row for each parameter used by default when starting the processing activities given in cdb_activity_type.
cdb_queue	Each row details a queue.
Audit	
cdb_audit_n	Set of 7 tables. Each row records which database tables have been changed and the type of change, eg. insert. Refer to section 9 for further information.
cdb_audit_fields_n	Set of 7 tables, each of which corresponds to a cdb_audit_n table. Each row records field values after an auditable change. Refer to section 9 for further information.
File Information	
cdb_file_reference	Each row details a file received and generated by the ISRA application software, excluding temporary files.
cdb_data_file	Each row contains information about a data file, in addition to cdb_file_reference.
cdb_instruction_file	Each row contains information about an instruction file, in addition to cdb_file_reference.
cdb_default_directory	Records the directory into which a file of a particular type should be placed when its status changes. Refer to Section 6.3 for further information.
cdb_file_export	Contains a row for each file waiting to be sent to the Gateway machine.
cdb_export_configuration	Contains a row for each file type that is exported. (This table is populated manually during installation, and can be maintained manually. Refer to the ISRA Installation Guide for further details).
cdb_file_directory	This table holds the Operating System path of the directories that make up the local file store, and indicates the directories to be monitored for the arrival of new files. Refer to section 6.1 for further information.
cdb_file_processing	Each row defines a type of file that is handled by the File Receipt process.
idb_flat_file_roots	Each row defines the root directory location of ISRA Flat Files which relate to a certain period of Settlement Dates.

Table or View Name	Description
Parameters	
cdb_system_parameter	Contains a row for every system parameter. Refer to section 7 for further information.
cdb_error_messages	Contains a row for each error message used by the ISRA forms application.
cdb_ref_domains	Contains an entry for each domain (data field for which there are a limited set of values).
cdb_ref_values	Holds valid values for each domain held in cdb_ref_domains.
Formatted Reports	
cdb_field_headers	Contains details of field headers to be used in formatted reports.
cdb_field_info	Holds details of the fields in the reports.
cdb_record_info	Holds information on the relationship between records in a report.
cdb_record_sections	Holds information on report section headings.
cdb_report_access	Defines which reports each user role can access via the Select Reports form.
cdb_report_file	Each row contains information about report files that can be viewed via the Select Reports form.
cdb_report_type	Each row contains a report that can be accessed by users from the PC via the Select Report form.
ISRA Business Specific	
idb_afycs	Defines Average Fractions of Yearly Consumption.
idb_bm_unit_in_gsp_groups	Defines the BM Units allocated to a given GSP Group and Supplier.
idb_clock_intervals	'On' time of a clock based on a Time Pattern Regime.
idb_consum_comp_classes	Class of Half Hourly Consumption and Non-Pooled Generation which has been calculated or aggregated.
idb_da_in_gsp_groups	Contains details of Data Aggregator appointments to Suppliers in GSP Groups.
idb_da_summaries*	Summary of idb_da_in_gsp_groups, used in some forms.
idb_daily_pfl_parameters	For each combination of GSP Group and Settlement Date, contains parameter values used in Period Regression Equations.
idb_df_standing_data	Used by DF Standing Data Control Matrix form.
idb_duplicate_spm	Used as a staging table to insert SPM records when loading the SPM data file. At the end of file loading, all the records from this table will be deleted.
idb_sent_by_mkt_ppts	Used by DF Standing Data Control Matrix form.
idb_file_type_source_roles	Contains valid market roles of sources for files of particular file types.
idb_gsp_group_average_eacs	Contains Average EACs for GSP Groups.
idb_gsp_group_cctn_sf_ssr_runs	GSP Group Correction Scaling Factor used in a particular SSR Run.
idb_gsp_group_cctn_sfs	Degree to which a GSP Group Correction Factor is applied to a Consumption Component Class.
idb_gsp_group_takes	Summed metered consumptions for GSP Groups in a half-hour Settlement Period.
idb_gsp_group_take_revisions	A set of Revised GSP Group Takes for a whole settlement day and GSP Group.

Table or View Name	Description
idb_gsp_groups	Contains details of GSP Groups.
idb_gsp_temp_load	Used by temperature maintenance form.
idb_nhh_bm_unit_allocation	Mappings of VSCPCs to BM Units for Supplier in GSP Group.
idb_llf_classes	Classification of Line Loss Factors by Distributor.
idb_load_da_gg_setts*	Used by Data Loading forms.
idb_load_gg_takes*	Used by Data Loading forms.
idb_load_sett_prices*	Used by Data Loading forms.
idb_load_timestamps*	Used by Data Loading forms.
idb_measurement_requirement	Standard Settlement Configuration requirement for consumption during a Time Pattern Regime.
idb_mkt_ppt_role_in_gsp_groups	Indicates Suppliers in GSP Groups, Data Collectors in GSP Groups and Distributors in GSP Groups.
idb_mkt_ppt_roles	Each row indicates a role to which a Market Participant has been assigned.
idb_mkt_ppts	Each row identifies a market participant.
idb_params	Each row identifies a parameter for a particular report used by the ISRA reporting mechanism.
idb_pd_pfl_reg_coefs	Each row contains a regression equation for a profile, season and day type.
idb_pd_sup_purchases	Each row identifies the total value of purchases for a Supplier within a GSP Group for a Settlement Period derived during a specific SSR Run for the Settlement Day.
idb_pfl_classes	Contains details of Profile Classes.
idb_pfl_production_runs	Contains details of Profile Production Runs for GSP Group.
idb_pfl_sets	Profile data as supplied by the Profile Administrator.
idb_pfls	Each row identifies a Profile for a Profile Class.
idb_rept_params	Contains parameters for ISRA reports.
idb_sett_pd_llfs	Contains Line Loss Factors to be applied for a Line Loss Factor Class during a Settlement Period.
idb_sett_pd_prices	Contains pricing and loss transmission data supplied by the SSA system.
idb_sett_types	Each row identifies a type of settlement or reconciliation that can be performed for a settlement day.
idb_settlement_days	Contains details of Settlement days.
idb_settlements	Schedule of settlements.
idb_ssa_sett_gsp_groups	Contains GSP Group Daily Purchases.
idb_ssa_sett_runs	Contains details of Preliminary, Provisional and Final SSA runs.
idb_sscs	Contains details of Settlement Configurations.
idb_ssr_run_gsp_group_pds	Contains information associated with each Settlement Period of an SSR for a GSP Group.
idb_ssr_run_gsp_groups	Each row identifies a run of SSR Initial Settlement or Reconciliation for a GSP Group.
idb_ssr_run_llf_files	Each row identifies an SSR run number, GSP group ID and LLF File ID.
idb_ssr_runs	Each row identifies a run of SSR Initial Settlement or Reconciliation.
idb_sup_data_agtns	Each row identifies the relationship between a Data Aggregator

Table or View Name	Description
	for a Supplier and a particular Data Aggregation.
idb_sup_data_agtns_in_ssr_runs	Contains relationships between a Supplier Aggregation and SSR runs.
idb_sup_gsp_da_auto_st_data	The table contains details of supplier and data aggregator appointment exceptions that have been encountered by the aggregated half hour data and supplier purchase matrix data loaders.
idb_teswitch_contact_rules	Contains relationships between a Tele-switch Contact and a Tele-switch Register Rule.
idb_teswitch_intervals	Contains details of 'on' intervals of a tele-switched Time Pattern Regime.
idb_tprs	Contains details of Time Pattern Regimes.
idb_tsw_contact_intervals	Contains details of an interval of time during which a particular Tele-switch Contact is in a particular state within all metering systems in a particular Tele-switch group.
idb_user_roles	Used by User Management form.
idb_vmr_pfl_classes	Each row identifies a Measurement Requirement within a valid Profile Class and Standard Settlement Configuration set.
idb_vspcs	Contains valid Standard Settlement Configurations for Profile Classes.
idb_llfdata	Contains Distributor Id, Line Loss Factor Class which is validated against data received from the Half Hourly Data Aggregator.
idb_cki_data	Contains the clock intervals data used to create the new time pattern file.
idb_ssc_tpr_data	Contains the Standard Settlement Id and Time Pattern Regime Id combination.
idb_demand_control_event	Contains the Demand Control Event details
idb_demand_control_instruction	Contains the Demand Control Instructions details

Table 5: Database Tables

5.2 Timestamps

Each record in `cdb_file_reference`, (each row details a file received and generated by the ISRA application software) uses one or more of the following timestamps:

- `creation_time` - the time at which the file was created by the ISRA application software;
- `received_time` - the time at which the file was received by the ISRA application software;
- `process_send_time` - the time at which the file was transmitted to the Gateway by the ISRA application software.

Each of these timestamps is held as a GMT value, reflecting the time format in the headers of the corresponding files.

Note that all other timestamps used in the ISRA application software are held in local time.

5.3 Domains

Lists of valid values of various columns are all combined into one table, to avoid the proliferation of small tables. Each set of values is called a domain. Two tables are defined to hold this information:

- **cdb_ref_domains** holds a record for each domain;
- **cdb_ref_values** holds a record for each value.

The domains held in the **cdb_ref_domains** table are as follows. Those domains marked with an asterisk are used for validation of numeric database fields and can be amended using the Reference Values form. The other domains can be browsed using this form.

- **AAEA** AA / EAC Indicator
- **ACES** Actual / Estimated Indicator
- **ACTD** Activity Description
- **AFYC** Average Fraction of Yearly Consumption*
- **AGSC** Aggregated supplier consumption*
- **AGSL** Aggregated supplier line loss*
- **AGTY** Aggregation Type (a subset of MAPR)
- **ASDC** Automatic Standing Data Change Reason Codes
- **AUDW** Standing Data Audit Warnings
- **BPPC** Basic period profile coefficient*
- **CDAR** Current Day Audit Report
- **CDCS** CDCS extract number*
- **COCO** Consumption Component Indicator
- **CPPC** Period Profile Class Coefficient*
- **DARN** Data aggregation run number*
- **DAYN** Day Number*
- **DAYT** Day Type Indicator
- **DAYW** Day of the Week Indicator
- **DEMC** SPM default EAC MSID count*
- **DGGP** Daily GSP Group purchases*
- **DPPA** Daily Profile Parameter*
- **DUMC** SPM default unmetered MSID count*
- **FITY** File Types
- **FSTS** File Status Type
- **GAAC** GSP Group average annual consumption*
- **GCSF** GSP Group Correction Scaling Factor*
- **GGCC** GSP Group Correction Factor*
- **GGTA** GSP Group take*

- **GMTT** GMT / Local time Indicator
- **HHMC** Data aggregator HH MSID count*
- **LFCI** Line Loss Factor Class Id*
- **LLFC** Line Loss Factor*
- **MAPR** Market Participant Role Code
- **MEQU** Measurement Quantity
- **MKDA** Data Aggregator Role Codes
- **MONN** Month Number
- **MONT** Month Indicator
- **MTUN** Metered / Unmetered Indicator
- **PFCI** Profile Class Id*
- **PFID** Profile Id*
- **PFST** Profile Production Run Status
- **PGGP** Period GSP Group purchases*
- **PLSP** Pool selling price*
- **PSPD** Profile settlement periods*
- **RCOT** Regression Coefficient Type
- **REGC** Regression Coefficient*
- **REPT** ISRA Report
- **RTCO** Run Type Code
- **RUST** SSR Run Status
- **SEAS** Season Code
- **SPID** Settlement period ID*
- **SSAR** SSA Settlement run number*
- **SSCT** SSC Type
- **TAAD** SPM total annualised advance*
- **TAMC** SPM total AA MSID count*
- **TEAC** SPM total EAC*
- **TEMC** SPM total EAC MSID count*
- **TPNS** Total period NPG spill*
- **TPRT** Time Pattern Regime Type
- **TTLA** Database Table three letter abbreviation
- **TUMC** SPM total unmetered MSID count*
- **TUNC** SPM total unmetered consumption*
- **TSCS** Tele-switch Contact Rule State

- **TSGI** Tele-switch Group Id*
- **TSUI** Tele-switch User Id*
- **TSWC** Tele-switch contact
- **TWIT** Tele-switch Switch Id Type
- **TXLM** Transmission loss multiplier*
- **TXRM** Transmission losses reconciliation multiplier*

When maintaining the Reference Values using the Maintain Reference Values form, (described in section 24 of the ISRA Operations Guide), the precision of numeric range values should not be altered to exceed the precision of the underlying database fields; if the precision of a numeric range is set to exceed the precision of the underlying database fields, which correspond to the precision of data loaded from data files, the following message will be included in the data load exception report: ‘ORA-01438: value larger than specified precision allows for this column’.

5.4 Database Sizing

An overall summary of the estimated database size is given in the following table:

Element	Size (Gbytes)
Oracle Database total	40
Flat File Database Total	2217
Overall Total	2257

Table 6: Database Organisation - Database Size

This is made up of 2 elements, standing data and data increasing on a daily basis, broken down as follows:

Element	Standing Data (Bytes)	Daily Growth (Bytes)
Oracle Database	91,573,610	58,952,678
Flat File Database	0	3,256,824,381

Table 7: Database Size – Standing Data and Daily Growth

For further details of the parameters used to calculate the sizing information, refer to the ISRA Logical Data Design (100PZT) and ISRA Technical Specification (110PZT).

5.4.1 Volumes of Reports and Other Files

Description	Value	Per	
Reports per SSR Run	274	SETLMN T	7 per supplier, + 1 per supplier & distributor + 1 for PFA + 1 to NGET [P192]
Daily Other Reports	167	SD	1 per Data Collector + 3 per Data Collector and Supplier
Flat Files	565	SD	1 idf_pd_time_pattern_state + (1 idf_pd_pfl_class_coef + 1 idf_basic_pd_pfl_coef + 1 idf_combined_pdPpfl_coef) per GSP Group + + ((1 idf_agtd_sup_da_pd_consum per HHDA per GSP Group) + (1 idf_sup_purchase_matrices per NHHDA per GSP Group)) per settlement code + (1 idf_agtd_sup_pd_consum + 1 idf_pfld_spm + idf_agtd_bm_pd_consums) per GSP Group per settlement code
Flat File Directories	20	SD	1 settlement date + 1 Period time pattern state + 1 profile + (1 data in + (1 per SSR Run)) per settlement code
Other Data Loads	94	Year	1 LLF file per Distributor + 12 Pool market domain data files + 4 Regression Equation Data files + 1 Sunset Data File + 12 Profile Data Files 1 Data Aggregation and Settlement Timetable File + 24 Market Domain Data Complete Set Files
Daily Data Loads	2014	SD	GSP Group Takes + Aggregated HH Data + Settlement Price Data + Supplier Purchase Matrix data file

Table 8: Database Sizing - Volumes of Reports and Other Files

5.4.2 ISRA Settlement Run Related Data

Table	# rows	rowsize	Table Data	Size		Index	Size	
IDB_GSP_GROUP_CCTN_SF_IN_SSR_RUNS	116,960	18	2,629,001	3	Mb	3,943,501	4	Mb
IDB_PD_SUP_PURCHASES	66,140,880	68	5,247,176,480	5	Gb	7,870,764,720	7	Gb
IDB_SSR_RUNS	3,655	37	160,741	157	Kb	241,111	235	Kb
IDB_SSR_RUN_GSP_GROUPS	47,515	23	1,335,040	888	Kb	2,002,559	1	Mb
IDB_SSR_RUN_GSP_GROUP_PDS	2,280,720	53	141,966,048	135	Mb	212,949,072	203	Mb
IDB_SSR_RUN_LLF_FILES	237,575	17	5,072,446	5	Mb	7,608,668	7	Mb
IDB_SUP_DATA_AGTNS	4,133,805	48	232,296,875	222	Mb	348,445,313	332	Mb
IDB_SUP_DATA_AGTN_IN_SSR_RUNS	4,133,805	37	181,797,555	173	Mb	272,696,332	260	Mb

Table 9: Database Sizing - ISRA Settlement Run Related Data

5.4.3 Line Loss Factors

Table	# rows	rowsize	Table Data	Size		Index	Size	
IDB_SETT_PD_LLFS	228,773,760	37	10,061,072,097	9	Gb	15,091,608,146	14	Gb

Table 10: Database Sizing – Line Loss Factors

5.4.4 Profile Run Data

Table	# rows	rowsize	Table Data	Size		Index	Size	
IDB_PFL_PRODUCTION_RUNS	10,453	37	459,718	449	Kb	689,577	673	Kb

Table 11: Database Sizing – Profile Run Data

5.4.5 Other Daily Data

Table	# rows	rowsize	Table Data	Size		Index	Size	
IDB_DAILY_PFL_PARAMETERS	9,503	29	331,458	324	Kb	497,187	486	Kb
IDB_SETTLEMENTS	3,655	30	131,450	128	Kb	197,175	193	Kb
IDB_SETTLEMENT_DAYS	731	33	28,855	28	Kb	43,282	42	Kb
IDB_TELESWITCH_INTERVALS	701,760	28	23,661,008	23	Mb	35,491,512	34	Mb
IDB_TSW_CONTACT_INTERVALS	935,680	30	33,651,211	32	Mb	50,476,817	48	Mb

Table 12: Database Sizing – Other File Data

5.4.6 SSA Settlement

Table	# rows	rowsize	Table Data	Size		Index	Size	
IDB_GSP_GROUP_TAKES	912,288	42	45,289,782	43	Mb	67,934,673	65	Mb
IDB_SETT_PD_PRICES	70,176	38	3,154,801	3	Mb	4,732,202	5	Mb
IDB_SSA_SETT_GSP_GROUP	19,006	31	705,489	689	Kb	1,058,233	1	Mb
IDB_SSA_SETT_RUNS	1,462	20	36,179	35	Kb	54,268	53	Kb

Table 13: Database Sizing – SSA Settlement

5.4.7 Profile Sets

Table	# rows	rowsize	Table Data	Size		Index	Size	
IDB_PD_PFL_REGR_COEFS	133,632	32	5,124,882	4	Mb	7,687,323	6	Mb
IDB_PFL_SETS	96	17	8,092	8	Kb	12,138	12	Kb

Table 14: Database Sizing – Profile Sets

5.4.8 Fixed Volume Standing Data

Table	# rows	rowsize	Table Data	Size		Index	Size	
IDB_AFYCS	32,400	44	1,680,646	2	Mb	2,520,969	2	Mb
IDB_BM_UNIT_IN_GSP_GROUPS	4,000	43	202,300	198	Kb	303,450	296	Kb
IDB_CLOCK_INTERVALS	71,344	32	2,736,093	3	Mb	4,104,140	4	Mb
IDB_CONSUM_COMP_CLASSES	32	19	8,092	8	Kb	12,138	12	Kb
IDB_DA_IN_GSP_GROUPS	767	39	35,466	35	Kb	53,199	52	Kb
IDB_GSP_GROUPS	13	56	8,092	8	Kb	12,138	12	Kb
IDB_GSP_GROUP_AVERAGE_EACS	1,248	31	46,325	45	Kb	69,487	68	Kb
IDB_GSP_GROUP_CORRECTION_SFS	64	26	8,092	8	Kb	12,138	12	Kb
IDB_LLF_CLASSES	6,520	32	250,047	244	Kb	375,070	366	Kb
IDB_MKT_PPTS	77	49	8,092	8	Kb	12,138	12	Kb
IDB_MKT_PPT_ROLES	77	17	8,092	8	Kb	12,138	12	Kb
IDB_MKT_PPT_ROLE_IN_GSP_GROUPS	473	32	18,140	18	Kb	27,210	27	Kb
IDB_MEASUREMENT_REQUIREMENTS	4,500	14	80,920	79	Kb	121,380	119	Kb
IDB_NHH_BM_UNIT_ALLOCATION	7,246	44	375,863	367	Kb	563,795	551	Kb
IDB_PFLS	48	81	8,092	8	Kb	12,138	12	Kb
IDB_PFL_CLASSES	8	70	8,092	8	Kb	12,138	12	Kb
IDB_SETT_TYPES	5	40	8,092	8	Kb	12,138	12	Kb
IDB_SSCS	1,500	66	155,600	113	Kb	173,400	169	Kb
IDB_TELESWITCH_CONTACT_RULES	3,200	17	68,323	67	Kb	102,484	100	Kb
IDB_TPRS	4,560	65	344,855	337	Kb	517,283	505	Kb
IDB_VMR_PFL_CLASSES	16,200	19	383,305	374	Kb	574,958	561	Kb
IDB_VSCPCS	4,500	27	146,831	143	Kb	220,246	215	Kb

Table 15: Database Sizing – Fixed Volume Standing Data

5.4.9 Use of Supporting Tables

Table	# rows	rowsize	Table Data	Size		Index	Size	
IDB_PARAMS	30	204	8,092	8	Kb	12,138	12	Kb
IDB_REPT_PARAMS	500	34	20,230	20	Kb	30,345	30	Kb
IDB_FILE_TYPE_SOURCE_ROLES	500	17	32,768	32	Kb	32,768	32	Kb

Table 16 Database Sizing – Use of Supporting Tables

5.4.10 Use of Common Database Tables

Table	# rows	rowsize	Table Data	Size		Index	Size	
CDB_ACTIVITY	2,607,644	61	185,096,983	177	Mb	277,645,474	265	Mb
CDB_ACTIVITY_PARAMETER	5,215,288	44	270,526,360	258	Mb	405,789,540	387	Mb
CDB_ACTIVITY_TYPE	10	237	8,092	8	Kb	12,138	12	Kb
CDB_DATA_FILES	2,698,200	33	106,506,509	102	Mb	159,759,764	152	Mb
CDB_DEFAULT_DIRECTORY	51	19	8,092	8	Kb	12,138	12	Kb
CDB_DEFAULT_PARAMETER	75	44	8,092	8	Kb	12,138	12	Kb
CDB_ERROR_MESSAGES	500	62	36,125	35	Kb	54,188	53	Kb
CDB_EXPORT_CONFIGURATION	51	251	14,450	14	Kb	21,675	21	Kb
CDB_FIELD_HEADERS	3,334	103	392,700	383	Kb	589,050	575	Kb
CDB_FIELD_INFO	1,131	32	42,186	41	Kb	63,279	62	Kb
CDB_FILE_DIRECTORY	14,640	225	3,821,512	4	Mb	5,732,268	5	Mb
CDB_FILE_EXPORT	1,130,857	23	31,773,940	30	Mb	47,660,911	45	Mb
CDB_FILE_PROCESSING	10	21	8,092	8	Kb	12,138	12	Kb
CDB_FILE_REFERENCE	4,959,914	96	549,803,070	524	Mb	824,704,605	786	Mb
CDB_INSTRUCTION_FILE	0	25	8,092	8	Kb	12,138	12	Kb
CDB_QUEUE	10	20	8,092	8	Kb	12,138	12	Kb
CDB_RECORD_INFO	119	20	8,092	8	Kb	12,138	12	Kb

Table	# rows	rowsize	Table Data	Size		Index	Size	
CDB_RECORD_SECTIONS	100	20	8,092	8	Kb	12,138	12	Kb
CDB_REF_DOMAINS	30	41	8,092	8	Kb	12,138	12	Kb
CDB_REF_VALUES	300	798	269,733	263	Kb	404,600	395	Kb
CDB_REPORT_FILE	1,130,857	17	24,144,841	23	Mb	36,217,262	35	Mb
CDB_REPORT_TYPE	23	43	8,092	8	Kb	12,138	12	Kb
CDB_SYSTEM_PARAMETER	50	65	8,092	8	Kb	12,138	12	Kb
Total			16,471,574,711	15	Gb	24,707,362,067	23	Gb

Table 17: Database Sizing – Use of Common Database Tables

5.5 Physical Organisation (Tablespaces/Files)

The physical configuration of an installation of the ISRA system is dependent on the installation environment, in particular the number and capacity of disks and number of processors.

The principal parameters that need to be taken into consideration are as follows:

1. System files (i.e. operating system), Paging space;
2. ISRA executables, Oracle executables, Paging space, Log files (Operator Logs, Error Logs, Process Output Logs);
3. Oracle Redo Logs;
4. Rollback segments;
5. Sort space;
6. idb_sup_pd_purchases table space (on 2 disks);
7. Other table spaces (on 3 disks);
8. idb_sup_pd_purchases index (on 2 disks);
9. Other database indices;
10. Miscellaneous, e.g. directory required by File Receipt process;
11. Flat file store (on many disks);
12. Other files (those not in flat file store).

The tablespace allocations for two specific configurations are given in Appendices C and D of the ISRA Installation Guide. Appendix D of that guide also gives the data file sizes and placements for the two configurations used for Performance Testing. The information given could also be used as input to considerations for sizing and layout of systems at other sites.

To enable printing of the £ sign in ISRA reports, the Oracle character set should be set to “AMERICAN_AMERICA.WE8ISO8859P1”.

5.6 Oracle Parameters

The parameters listed below are identified as necessary for ISRA to work correctly. Other parameters can be set to tune the Oracle instance or run it in a certain way. For further information about Oracle Parameters, refer to the ISRA Installation Guide.

Parameter	Value	Comment
compatible	11.2.0	development and testing Oracle release number for ISRA
log_archive_dest	<directory>	must be set to a directory spec - actual value unimportant
log_archive_start	true	enables archive logging
log_checkpoint_interval	larger than redo log size	ensures that checkpoints do not happen between log switches
log_checkpoint_timeout	0	ensures that checkpoints do not happen between log switches

Parameter	Value	Comment
processes	50 or above	number of concurrent processes that can run against database
row_locking	always	enables row-level locking
utl_file_dir	*	enables access to all directories

Table 18: Physical Organisation – Oracle Parameters

5.7 Some Considerations for Performance Optimisation

Experience gained from the Valbonne performance tests include the following pointers to configuring the system for optimal performance.

a. Database Indexes

To minimise disk I/O constraints, it is essential to locate a file and its corresponding index on separate disk spindles.

b. Oracle Initialisation Parameters

There are two key parameters for tuning consideration:

- **shared_pool_size:** This parameter determines the amount of memory set aside for the data dictionary cache and the shared SQL area. The cache hit ratio for this can be monitored using standard Oracle scripts to determine the best values. In a running system, large users of this buffer are SQL statements.
- **db_block_buffers:** This parameter defines the cache used for data. This parameter can be tuned by using an Oracle script to examine the cache hit rate.

The values used for the Valbonne performance tests are given in Appendix D.6 of the ISRA Installation Guide.

c. Splitting Data Across Disks or Directories (see section 6.1)

Where significant volumes of data are expected, it should be split off to separate volumes using links, (see section 6.1).

A similar mechanism can be used to ‘stripe’ the data for particular GSP Groups, i.e. configuration such that all data for a particular GSP Group is placed physically together.

The various database files that could be split across disks to tune performance are shown in Appendix D.3.1 of the ISRA Installation Guide.

d. Processor Queue Widths (see section 6.6, and Appendix D.4 of the ISRA Installation Guide)

Queues control the number of jobs of a given type that are running simultaneously. If multiple streams of work are occurring, then queues should be set so that there is not too much contention, but avoiding one queue active for some time after all others finish. For example, on a 12 processor machine, the following queues could be used:

- **isra_sub** set to the number of GSP Groups plus 2 for profiling, so that the process occurs in parallel;

- `isra_duos` and `isra_rpt` used to ensure that all SSR report jobs finish at a similar time. The actual number of jobs permitted on each is tuned on the system in situ;
- `isra_du2` used to ensure that the longest DUOS reports, i.e. the Distributor DUOS reports, are started immediately;
- `irpgsp` used when there is more than one GSP Group, to ensure that all GSP Groups are processed simultaneously, i.e. width equals number of GSP Groups.

6 System Organisation

This section contains information on the structure of the ISRA system in terms of directories and files; lists the environment variables that have been created for the ISRA system; describes the batch queues that are used by the Scheduler subsystem.

6.1 Directory Structure

The `cdb_file_directory` table holds the Operating System paths of the directories that make up the local file store and indicates the directories to be searched for the arrival of new files.

This table is initially populated through SQL during system installation. Refer to the ISRA Installation Guide for further information. No facilities are provided to maintain this table through the user interface.

The 'source_directory' field in the `cdb_file_directory` table is set to 'Y' if the directory should be scanned by the File Receipt Manager when looking for incoming files.

In the `cdb_file_directory` table, the 'path' field contains the POSIX path for the directory. If all database files (described in section 6.2) have been deleted from a particular directory during archive, then the 'path' field value will be set to null.

For example:

directory_id	100
path	\$RUNTIME/in/new
source_directory	Y

Table 19: Directory Structure - Example

The default directory structure is shown below. Note that the \$RUNTIME directory is an environment variable, which is optionally created during installation.

```

$RUNTIME-----
    +-> bin
    +-> data -----+> lsdm
    +-> etc
    +-> forms -----+> icons
    +-> sql
    +-> csc_log
    +-> backup_logs
    +-> oracle -----+> database
        |                +-> redo_logs
        |                \-> control_files
        |
    +-> in -----+> new
        |                \-> received ---+> spm
        |
        |                +-> dpm
        |                +-> hhdadd
        |                +-> dce
        |                +-> dci
        |                +-> ddmsi
  
```



```
- | +-> hhda |
  | +-> sunset |
  | +-> iessa |
  | +-> market |
  | +-> regression |
  | +-> lineloss |
  | +-> rggt |
  | +-> tsw |
  | +-> sett |
  | +-> mddcs |
  | +-> bmu |
  | +-> lsdm |
  | +-> out -----+-> raw -----+-> tuos |
  | | | | | | +-> hhdemand |
  | | | | | | +-> bustev |
  | | | | | | +-> busgdd |
  | | | | | | +-> duos |
  | | | | | | +-> sshdr |
  | | | | | | +-> spmrep |
  | | | | | | +-> spbmu |
  | | | | | | +-> spurchase |
  | | | | | | +-> poolfunds |
  | | | | | | +-> dpceextract |
  | | | | | | +-> poolperf |
  | | | | | | +-> poolmisc |
  | | | | | | +-> deemtake |
  | | | | | | +-> prssc |
  | | | | | | +-> prstanding |
  | | | | | | +-> prdaily |
  | | | | | | +-> teler2 |
  | | | | | | +-> ggcf |
  | | | | | | \-> gspgct |
  | | | | | | \-> formatted |
  | | | | | | |
  | +-> tmp -----+-> TEMP |
  | | +-> tswid |
  | | |
  | \-> audit -----+-> oplog |
  | | +-> errlog |
  | | +-> except |
  | | +-> other |
  | | +-> stanman |
  | | +-> corrupt |
  | | +-> audit_log |
  | | +-> updates |
  | | \-> sdu |
```

Figure 12: ISRA Default Directory Structure

In general, the files stored in these directories are determined by the contents of `cdb_default_directory`, which identifies the location of files of a particular status. Refer to section 6.3 for further details. ISRA flat files are stored under the directory specified by the 'Flat File Toplevel Directory' system parameter as default. Alternatively, some or all of them can be distributed between a number of different directories, according to the Settlement Date to which they refer. These directories may, nor may not, lie beneath `$RUNTIME`. They can be configured by

the System Manager, as a first step in managing the hard disk space available on the server. Refer to Section 6.4 for further details.

The `csc_log` directory, used to store logs of batch processes controlled by the Scheduler, is a system parameter. The actual directory is specified in the `cdb_system_parameters` table, described in section 7. For further information about scheduler logs, refer to section 11.2.

The `bin` directory contains the ISRA executables.

To further support file and space management, symbolic links can be defined, using Operating System functionality, from directories under `$RUNTIME` to directories on other disks. This may be important where the directories contain significant volumes of data, e.g. data and duos directories. Figure 13 illustrates a link from the `$RUNTIME/data/.../profiles` directory to a different disk.

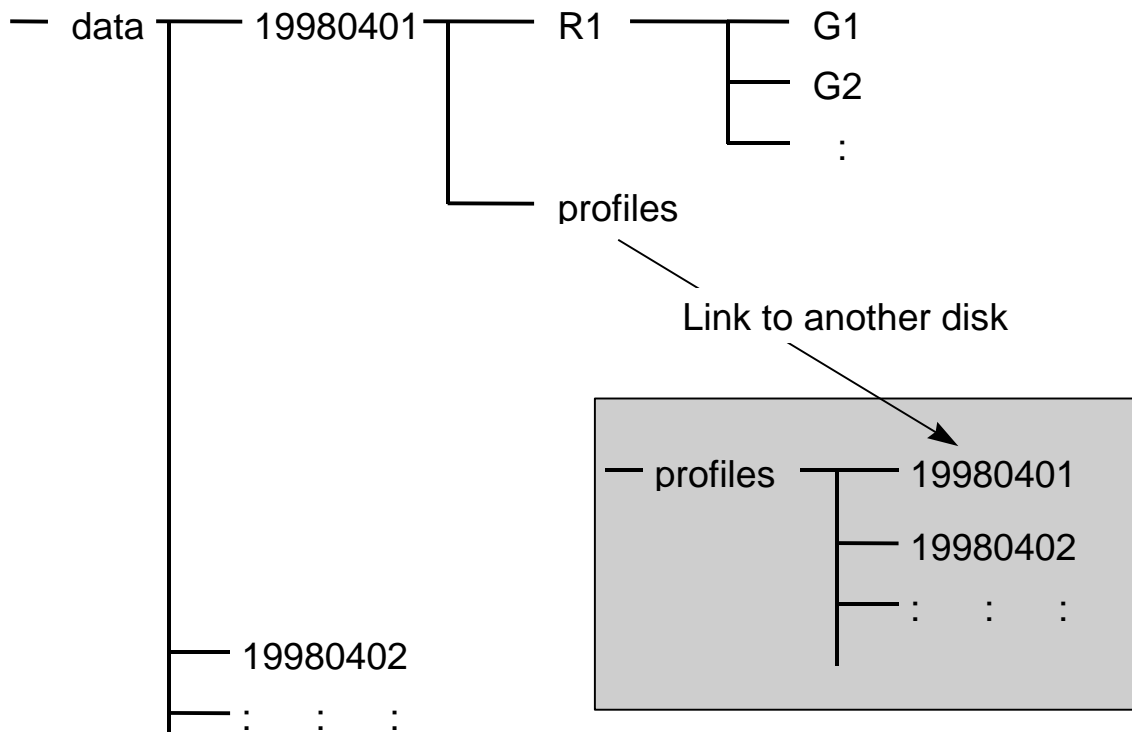

Figure 13: Symbolic Links from \$RUNTIME Directories

Another mechanism for determining the location of ISRA files is the `cdb_default_directory` table. Refer to section 6.3 for further details.

6.2 File Names

For files received from the Gateway, the filename must be unique across all possible sources and for POSIX compliance, must be 14 characters or less.

For files sent to the Gateway, filenames are unique. The format of filenames is as follows:

```
<market participant role code><market participant id><9 digit file_id>
```

Additionally, some of the data used by the ISRA system is contained in data files. The filename format for these files is file-specific and is listed below:

Identifier	Filename	Description
idf_sup_purchase_matrices	n<da_id><agg_run>.d	Supplier Purchase Matrix file. Each row contains Supplier Purchase Matrix details. A new file is created for each combination of Settlement Date, Settlement Code and GSP Group.
idf_agtd_sup_da_pd_consums	h<da_id><agg_run>.d	Aggregated Supplier DA Period Consumption file. Contains details of aggregated HH metered consumption, Non-Pooled Generation or line loss for a Supplier, within a GSP Group. For Settlement Days before the start of the NETA the consumption is by Consumption Component Class for a Settlement Period. For Settlement Days from the start of the NETA the consumption is by BM Unit, Consumption Component Class for a Settlement Period. A new file is created for each combination of Settlement Date, Settlement Code and GSP Group.
idf_agtd_sup_pd_consums	aspc.d	Aggregated Supplier Period Consumption file. Contains details of aggregated profiled consumption or line loss for a Supplier, within GSP Group, by Consumption Class for a Settlement Period.
idf_agtd_bm_pd_consums	abpc.d	Aggregated BM Unit Period Consumption file (only created for SSR Runs for Settlement Days from the start of the NETA). Contains details of aggregated profiled consumption or line loss for a BM Unit for Supplier within GSP Group, by Consumption Class for a Settlement Period.
idf_pfld_spms	pspm.d	Profile SPM file. Contains results of applying half hourly profiles to EAC, AA and Unmetered totals in a Supplier Purchase Matrix.
idf_pd_pfl_class_coefs	ppcc<Gsp_Id>.d	Period Profile Class Coefficient file. Contains details of coefficients that when applied to an EAC or AA value, supplies an estimate of consumption for a specific Settlement Period. Coefficient values are derived for a Profile Class within Time Pattern Regime, taking into account any switched load or chunking.
idf_basic_pd_pfl_coefs	bppc<Gsp_Id>.d	Basic Period Profile Coefficient file, Contains details of coefficients that when applied to an EAC or AA value, supplies

Identifier	Filename	Description
		an estimate of consumption for a specific Settlement Period. Coefficient values are derived for a Profile Class within a GSP Group, without modification for any particular Time Pattern Regime.
idf_combined_pd_pfl_coefs	cppc<Gsp_Id>.d	Combined Period Profile Coefficient file. Contains details of coefficients that when applied to an EAC or AA value, supplies an estimate of consumption for a specific Settlement Period. Coefficient values are derived for each valid combination of Switched Load profile Class and Standard Settlement Configuration, and includes both the base and switched load components.
idf_pd_time_pattern_states	tpr.d	Period Time Pattern State file. Contains details of the state of a Time Pattern Regime during a Settlement Period, indicating whether the Time Pattern is On or Off.
idf_agtd_sup_da_pd_consums_llf	g<da id><agg run>.d	Aggregated Supplier DA Period Consumption file. Contains details of aggregated HH metered consumption, Non-Pooled Generation or line loss for a Supplier, within a GSP Group. A new file is created for each combination of Settlement Date, Settlement Code and GSP Group. It is similar to the idf_agtd_sup_da_pd_consums. It additionally contains the Distributor Id and Line Loss Factor Class Id.
idf_tpr_time_patterns	tpr2.d	Period Time Pattern State file. Contains details of the state dummy SSC and Time Pattern Regime combinations during a Settlement Period, indicating whether the Time Pattern is On or Off
idf_llf_ssc_mapn	l<ddmmhh24mmss>.d	Line Loss Standard Settlement Mapping Data file. Contains the Line loss factor class id and distributor combination along with the Dummy SSC and Time Pattern Regime Combination with the respective Clock interval details.
idf_discon_purchase_matrices	bdn<da id><agg run>.d	Disconnection Purchase Matrix file. Each row contains Disconnection Purchase Matrix details. A new file is created for each combination of Settlement Date, Settlement Code and GSP Group.
idf_agtd_sup_da_pd_discon_volume	adn<da id><agg run>.d	Aggregated Supplier DA Period Disconnection Volume file. Contains details of aggregated HH metered Disconnection Volume, Non-Pooled Generation or line loss for a Supplier.

Identifier	Filename	Description
		<u>within a GSP Group.</u>
<u>idf_agtd_sup_pd_discon_v olume</u>	<u>aspdv.d</u>	<u>Aggregated Supplier Period Disconnection Volume file.</u> <u>Contains details of aggregated profiled consumption or line loss for a Supplier, within GSP Group, by Consumption Class for a Settlement Period.</u>
<u>idf_agtd_bm_pd_discon_v olume</u>	<u>abpdv.d</u>	<u>Aggregated BM Unit Period Disconnection Volume file.</u> <u>Contains details of aggregated profiled consumption or line loss for a BM Unit for Supplier within GSP Group, by Consumption Class for a Settlement Period.</u>
<u>idf_pfld_dpms</u>	<u>pdpm.d</u>	<u>Profile DPM file.</u> <u>Contains results of applying half hourly profiles to EAC, AA and Unmetered totals in a Disconnection Purchase Matrix.</u>

Table 20: System Organisation – File Names

where <...> are as defined in the Oracle database with numbers being zero padded.

6.3 File Locations

The cdb_default_directory table records the directory into which a file, of a particular file type, is placed when it changes to the specified status.

This table is used by a number of the file handling processes within the ISRA application software. For example, by the File Receipt Manager for determining where to place files that are received by the system.

The table is initially populated using SQL during system installation. Refer to the ISRA Installation Guide for further information. There is no user interface provided to maintain this table. The value for “directory_id” can be amended using interactive SQL; this mechanism can be used to store files of a particular status in a different location, thus assisting with space management.

Note that if new directories are created to store files of a particular status, a record needs to be added to the cdb_default_directory table, indicating the file type, file status, and path of the directory in which those files are to be stored. When performing this task manually, the ISRA Oracle sequence cdb_directory_sequence should be used to generate a unique directory_id value, to avoid conflicts in this key.

The following table identifies the File Type and Status combinations in cdb_default_directory that are used by the ISRA application software. For each combination of File Type and File Status, the directory path, relative to \$RUNTIME is given. Note that ‘...’ indicates further sub-directories, as shown in Figure 12.

File Type	Description	File Status	Location
D0041001	Supplier Purchase Matrix Data File	New	in/new/...
D004000 ³²	Aggregated Half Hour Data File		
P0011001	Sunset Data File		
P0012001	GSP Group Take Data File		
P0013001	Settlement Price Data File		
D0278002	Tele-switch Pool Market Domain Data File		
P0015001	Profile Data File		
P0014001	Regression Equations Data File		
P0214001	Scottish Regression Equations File ³		
D0265001	Line Loss Factor Data File		
D0279001	Tele-switch Contact Interval Data File		
D0286001	Aggregation Settlement Timetable Data File		
D0269002	Market Domain Data Complete Set File		
D029800 ³²	BM Unit Aggregated Half Hour Data File		
-D0299001	BM Unit Registration Data File		
<u>P0239001</u>	<u>Line Loss SSC Mapping Data File</u>		
<u>D0376001</u>	<u>Supplier's Demand Disconnection Volume Data File</u>		
<u>D0377001</u>	<u>Disconnection Purchase Matrix Data File</u>		
<u>D0378001</u>	<u>BM Unit Aggregated Half Hour Demand Disconnection Data File</u>		
<u>P0238001</u>	<u>MSIDs affected by Demand Control Event</u>		
<u>P0240001</u>	<u>Demand Control Instructions</u>		
<u>P0241001</u>	<u>Disconnected MSIDs and Estimated Half Hourly Demand Disconnection Volumes</u>		
D0041001	Supplier Purchase Matrix Data File	Received	in/received/...
<u>D004000³²</u>	Aggregated Half Hour Data File		
P0011001	Sunset Data File		
P0012001	GSP Group Take Data File		
P0013001	Settlement Price Data File		
D0278002	Tele-switch Pool Market Domain Data File		
P0015001	Profile Data File		
P0014001	Regression Equations Data File		
P0214001	Scottish Regression Equations File ³²		
D0265001	Line Loss Factor Data File		
D0279001	Tele-switch Contact Interval Data File		
D0286001	Data Aggregation Settlement Timetable Data File		
D0269002	Market Domain Data Complete Set File		
<u>D029800³²</u>	BM Unit Aggregated Half Hour Data File		
D0299001	BM Unit Registration Data File		
<u>P0239001</u>	<u>Line Loss SSC Mapping Data File</u>		
<u>D0376001</u>	<u>Supplier's Demand Disconnection Volume Data File</u>		
<u>D0377001</u>	<u>Disconnection Purchase Matrix Data File</u>		

³ This entry is not present as a result of LCR235.

File Type	Description	File Status	Location
D0378001	BM Unit Aggregated Half Hour Demand Disconnection Data File		
P0238001	MSIDs affected by Demand Control Event		
P0240001	Demand Control Instructions		
P0241001	Disconnected MSIDs and Estimated Half Hourly Demand Disconnection Volumes		
L0004001	Operator Log	Default	audit/oplog
L0005001	Error Log		audit/errlog
L0021001	Profile Run Exception Report		audit/except
L0008001	Data Loading Exception Report		audit/except
P0035001	Duplicate SPM Exception Report		audit/except
L0006001	Data Load Standing Data Update Report		audit/updates
L0030001	Audit Report		audit/other
L0031001	Standing Data Audit Report		audit/stanman
L0000001	Corrupt or unexpected file		audit/corrupt
L0001001	Audit Log		audit/audit_log
L0049001	Standing Data Update Report for Suppliers		audit/sdu
L0050001	LLF Confirmation		audit/other
D0041001	Supplier Purchase Matrix Data File	Default	audit/corrupt
D00400032	Aggregated Half Hour Data File		
P0011001	Sunset Data File		
P0012001	GSP Group Take Data File		
P0013001	Settlement Price Data File		
D0278002	Tele-switch Pool Market Domain Data File		
P0015001	Profile Data File		
P0014001	Regression Equations Data File		
P0214001	Scottish Regression Equations File ³²		
D0265001	Line Loss Factor Data File		
D0279001	Tele-switch Contact Interval Data File		
D0286001	Data Aggregation Settlement Timetable Data File		
D0269002	Market Domain Data Complete Set File		
D02980023	BM Unit Aggregated Half Hour Data File		
D0299001	BM Unit Registration Data File		
D0376001	Supplier's Demand Disconnection Volume Data File		
D0377001	Disconnection Purchase Matrix Data File		
D0378001	BM Unit Aggregated Half Hour Demand Disconnection Data File		
P0238001	MSIDs affected by Demand Control Event		
P0240001	Demand Control Instructions		
P0241001	Disconnected MSIDs and Estimated Half Hourly Demand Disconnection Volumes		
P0210001	TUoS Report (HH/NHH split)	Default	out/raw/...
D0081001	HH Demand Report		
D0030001	DUoS Report		
D9903001	Supplier Settlement Header Report		
D0082001	Supplier Purchase Matrix Report		
D0079001	Supplier Purchase Report		

File Type	Description	File Status	Location
D0039001	Daily Profile Coefficient File		
P0182001	BM Unit Supplier Take Energy Volume Report		
P0236001	BM Unit SVA Gross Demand Report		
D0043001	Deemed Take Report		
D0029001	Standard Settlement Configuration Report		
D0028001	Standing Profile Data Report		
D0018001	Daily Profile Data Report		
D0276002	GSP Group Consumption Totals Report		
D0279001	Tele-switch Contact Interval Data Report		
D0296001	Supplier BM Unit Report		
D0369001	Aggregated Disconnected DUoS Report		
D0370001	Supplier Half Hourly Demand Disconnection Report		
D0371001	Supplier - Supplier Disconnection Matrix Report		
D0373001	GSP Group Demand Disconnection Totals Report		
D0374001	Supplier BM Unit Demand Disconnection Report		
D0375001	Disconnected MSIDs and Estimated Half Hourly Demand Disconnection Volumes		

Table 21: System Organisation – File Locations

If the Status in `cdb_default_directory` is “default”, then files are placed in the associated directory if the combination of file type and the file’s current status is not given in the `cdb_default_directory` table.

A File Type of ‘L0000001’ is used to manage unreadable or unrecognised files, when:

- The filename or file header cannot be decoded or validation checks fail;
- An unrecognised file type is received (i.e.: there is no corresponding row in the `cdb_file_processing` table).

All report files generated by the system are retained in the output directory.

The Profile Production process creates a single copy of each of the following report files before sending to appropriate Market Participants:

- Standard Settlement Configuration;
- Standing Profile Data;
- Daily Profile Data;
- Tele-switch Contact Interval Data.

Copies of the files sent out are retained on-line in the output directory.

6.4 Flat File Location

The default location for ISRA flat files is defined by the system parameter ‘Flat File toplevel Directory’ (which has the value `$RUNTIME/data` as default). However, the ISRA flat file storage area can be distributed between several

different directories, on potentially different disks if required. These different directories are referred to as ‘ISRA Flat File Roots’ and they may, or may not, lie beneath the \$RUNTIME directory.

The ISRA flat files can be distributed between these directories according to the Settlement Date to which they refer. The relationships between Settlement Dates and ‘ISRA Flat File Roots’ are defined in the database table `idb_flat_file_roots` which is manually configured by the System Manager. The structure of the database table `idb_flat_file_roots` is as follows:

	Column Name	Properties
1	<code>eff_from_date</code>	
2	<code>eff_to_date</code>	
3	<code>path</code>	not null

Table 22: System Organisation – Flat File Location

The directory that an ISRA Flat File is stored beneath is determined as follows:

- If the flat file relates to a Settlement Date which is not covered in `idb_flat_file_roots`, then it is stored beneath the default directory location, which is defined by the ‘Flat File Toplevel Directory’ system parameter.
- If the flat file relates to a Settlement Date that falls on or between the ‘`eff_from_date`’ date and the ‘`eff_to_date`’ of a particular record in `idb_flat_file_roots` then it is stored beneath the directory (the ‘ISRA Flat File root’) defined in the “`path`” column.
- If the flat file relates to a Settlement Date that falls between the ‘`eff_from_date`’ date and the ‘`eff_to_date`’ of two or more records in `idb_flat_file_roots` then an exception message is logged and the flat file is stored beneath the default directory location, which is defined by the ‘Flat File Toplevel Directory’ system parameter.

The database table `idb_flat_file_roots` should be manually configured by the System Manager and no records should have overlapping effective date ranges. `idb_flat_file_roots` is used both for creation of new ISRA flat files and also the opening of existing flat files, and it is the responsibility of System Manager to ensure that it remains consistent with the corresponding physical location of the flat files on disk. After installation, and once any flat files have been created, the records in `idb_flat_file_roots` must only be modified as part of a data migration procedure that also involves moving the physical flat files to the new directories. Changing the records in `idb_flat_file_roots` does not change the location on disk of any corresponding existing physical flat files.

The directory structure beneath each ‘ISRA Flat File root’ takes the format as follows:

Identifier	Filename	Path
<code>idf_sup_purchase_matrices</code>	<code>n<da_id><agg_run>.d</code>	<code><ROOT>/<SettDate>/<SettCode>/<GspId>/</code>
<code>idf_agtd_sup_da_pd_cons</code>	<code>h<da_id><agg_run></code>	<code><ROOT>/<SettDate>/<SettCode>/<GspId></code>

Identifier	Filename	Path
ms	>.d	>/
idf_agtd_sup_pd_consums	aspc.d	<ROOT>/<SettDate>/<SettCode>/<GspId>/
idf_agtd_bm_pd_consums	abpc.d	<ROOT>/<SettDate>/<SettCode>/<GspId>/
idf_pfld_spms	pspm.d	<ROOT>/<SettDate>/<SettCode>/<GspId>/
idf_pd_pfl_class_coefs	ppcc<Gsp_Id>.d	<ROOT>/<SettDate>/profiles/
idf_basic_pd_pfl_coefs	bppc<Gsp_Id>.d	<ROOT>/<SettDate>/profiles/
idf_combined_pd_pfl_coefs	cppc<Gsp_Id>.d	<ROOT>/<SettDate>/profiles/
idf_pd_time_pattern_states	tpr.d	<ROOT>/<SettDate>/
idf_agtd_sup_da_pd_consums_llf	g<da_id><agg_run>.d	<ROOT>/<SettDate>/<SettCode>/<GspId>/
idf_tpr_time_patterns	tpr2.d	<ROOT>/<SettDate>/
idf_llf_ssc_mapn	l<ddmmhh24mmss>.d	<ROOT>/data/l sdm/
Aggregated Supplier DA Period disconnection Volume	adh<da_id><agg_run>.d	<ROOT>/<Sett Date>/<Sett Code>/<GSP Id>/
Aggregated Supplier Period disconnection Volume	aspdv.d	<ROOT>/<Sett Date>/<Sett Code>/<GSPId>/<SSR_Run_No>/
Profiled DPM	pdpm.d	<ROOT>/<Sett Date>/<Sett Code>/<GSP Id>/<SSR_Run_No>/
Disconnection Purchase Matrix	bdm<da_id><agg_run>.d	<ROOT>/<Sett Date>/<Sett Code>/<GSP Id>/
Aggregated BM Unit Period disconnection Volume	abpdv.d	<ROOT>/<Sett Date>/<Sett Code>/<GSPId>/<SSR_Run_No>/

Table 23: Flat File Location - Identifiers

<SettDate> is of the form 'yyyymmdd'.

<ROOT> is either an 'ISRA Flat File root' directory for the Settlement Date or the default directory location, which is defined by the 'Flat File Toplevel Directory' system parameter

6.5 File Sizing

The following table provides estimates for the sizes of flat files used to store some items of ISRA data. The 'Retention Period' values are for two years of data.

Flat File	File Size (Bytes)	Per
idf_agtd_sup_da_pd_consums	1,024,026	Each
	26,624,676	HH data aggregator per supplier per GSP Group
	133,123,380	Settlement Day
	97,313,190,780	Retention Period
idf_agtd_sup_pd_consums	1,970,180	GSP Group
	25,612,340	Settlement Run

Flat File	File Size (Bytes)	Per
	128,061,700	Settlement Day
	93,613,102,700	Retention Period
idf_agtd_bm_pd_consums	15,812,959	GSP Group
	205,568,468	Settlement Run
	1,027,842,340	Settlement Day
	751,352,750,540	Retention Period
idf_pfld_spms	22,482,070	GSP Group
	292,266,913	Settlement Run
	1,461,334,566	Settlement Day
	1,068,235,567,454	Retention Period
idf_sup_purchase_matrices	4,936,135	Each
	64,169,755	GSP Groups
	320,848,775	Settlement Day
	234,540,454,525	Retention Period
idf_pd_pfl_class_coefs	13,721,436	GSP Group
	178,378,668	VMRPC
	130,394,806,308	Retention Period
idf_pd_time_pattern_states	948,516	Each
	693,365,196	Retention Period
idf_basic_pd_pfl_coefs	39,636	Each
	515,268	GSP Groups
	376,660,908	Retention Period
idf_combined_pd_pfl_coefs	2,893,856	Each
	37,620,128	Settlement Day
	27,500,313,568	Retention Period

Table 24: System Organisation – File Sizing

The following table summarises the estimated size of the flat files for the two year retention period.

Table	Table data	Size	
IDF_AGTD_SUP_DA_PD_CONSUMS	97,313,190,780	91	Gb
IDF_AGTD_SUP_PD_CONSUMS	93,613,102,700	87	Gb
IDF_AGTD_BM_PD_CONSUMS	751,352,750,540	700	Gb
IDF_PROFILED_SPMS	1,068,235,567,454	995	Gb
IDF_SUP_PURCHASE_MATRICES	234,540,454,525	218	Gb
IDF_PD_PFL_CLASS_COEFS	130,394,806,308	121	Gb
IDF_PD_TIME_PATTERN_STATES	693,365,196	1	Gb
IDF_BASIC_PD_PFL_COEFS	376,660,908	0.5	Gb
IDF_COMBINED_PD_PFL_COEFS	27,500,313,568	26	Gb

Table 25: System Organisation – Flat Files Estimated Size

6.6 Environment Variables

The directory under which all ISRA application software directories reside is an environment variable \$RUNTIME. The value of \$RUNTIME is defined at installation. Refer to the ISRA Installation Guide for further information.

6.7 Batch Queues

The ISRA system has three batch queues, `isra_main`, `isra_sub` and `isra_load`, which are set up during installation.

`isra_main` is ISRA's main queue, which is used by batch jobs. For example, Profile Production, Supplier and Settlement Reconciliation Runs.

`isra_sub` is used by batch jobs for which two (by default) processes (for the same or different `activity_type`) can run simultaneously. For example, many of the reporting processes can run at the same time.

`isra_load` is used by the data load processes for Line Loss Factor Classes, GSP Group Take, Settlement Price Data, Pool Market Data, Market Domain Data Complete Set, BM Unit Registration Data, Supplier Purchase Matrices, Aggregated Half Hourly Data, BM Unit Half Hour Data, Loading of Profile Data, Regression Equations Data, Scottish Regression Equations Data⁴, Data Aggregations and Settlements Timetable and Sunset Data. This is set to one and should not be changed.

Additional queues can be added manually; refer to the ISRA installation guide for further information. Note that any additional queues are only detected by the Scheduler when it starts up.

⁴ Loading of this data is disabled as a result of LCR235.

7 System Parameters

The ISRA system uses a number of System Parameters, which are stored in the `cdb_system_parameters` table.

The System Parameters shown in the table below can be modified using the Maintain System Parameter Values form, which is described in the ISRA Operations Guide. Any changes to System Parameters are recorded in the ISRA Audit Log. Refer to section 9 for further information about the Audit Log.

The default values for the maintainable parameters are also given. Further System Parameters which can only be defined during system installation are given in the ISRA Installation Guide.

Description	Default Value	Format/Units
BUSTEV Report Participant Id The participant id of the organisation to whom the BM Unit Supplier Take Energy Volume Reports are sent	UKDC	4 alpha numeric chars
BUSTEV Role Code The role code of the organisation to which BM Unit Supplier Take Energy Volume Reports are sent	F	1 alpha numeric char
CDCA Participant Id Defines the Central Data Collection Agent Participant for the system	UKDC	4 alpha numeric chars
CFS Timeout Retry delay between attempts to send a file	10	numeric/seconds
Closedown Timeout Delay between requesting scheduler closedown and exit	20	numeric/seconds
Data Retention Period The number of months that data must be retained on the system before it can be archived. This parameter should not be set to less than 24 months. This value should be numeric. There is no maximum value.	24	numeric/months
File send Alert timeout (secs) Time after which the File Send daemon wakes up if no new file sends are requested, and hence rechecks for files needing resending.	10	numeric/seconds
GSP daily purchases tolerance The tolerance value for GSP Group daily purchase validation during loading of GSP Group Take and Settlement Price data.	10	money value, e.g. 1.50
GSP period purchases tolerance The tolerance value for GSP Group period purchase validation during loading of GSP Group Take and Settlement Price data.	1	money value, e.g. 1.50
Log Directory The directory in which the Scheduler Logs are generated	../csc_log	path relative to the bin directory of the runtime installation tree

Description	Default Value	Format/Units
Number of sends The number of times the File Send process attempts to send a file.	3	numeric
Operating System Version The version of the Operating System on which the ISRA application software is running.	HP-UX B.11.31 U	
Pipe timeout (secs) Time after which if there is no response from the logger the application assumes that the logger daemon is dead.	5	numeric/seconds
Poll frequency (secs) The number of seconds between polling of the incoming file directory by the File Receipt process.	10	integer/seconds
Scheduler Alert timeout (secs) Time between successive polls for scheduled activities.	5	integer/seconds
TUOS Participant Id The participant id of the organisation operating the Transmission Use of System system, to which TUoS reports are sent.	TUOS	4 alpha numeric chars
TUOS Role Code The role code of the organisation operating the Transmission Use of System system, to which TUoS reports are sent.	Z	1 alpha numeric char
Warning file size (bytes) During an attempt to view a file, if the file size exceeds the warning file size the user will be prompted with a message to either continue or cancel the display of the file.	2000	numeric/bytes

Table 26: System Parameters

8 User Accounts, Privileges and Security

The ISRA system provides three levels of security:

- Server Operating System;
- Oracle database tables;
- Oracle forms.

Operating System accounts control access to server files and processes while Oracle roles are used to control access to forms and database tables.

8.1 Server Operating System

The Operating System controls server access through user accounts consisting of a logon name and a password. These accounts are set up by the System Manager. The concept of groups is supported such that users needing similar access to the system and associated files/directories can be allocated to the same group. For example, a user group can be created with a number of users each having a distinct name and password but having common access rights to files.

Each user requiring direct access to the server requires an Operating System account. Server file permissions need to be set to ensure that file access is limited to those applicable to the user role, e.g. prevent deletion or modification of certain files.

The mechanism by which this is achieved depends on the Operating System security features available. For example:

- File Permissions, as included in the POSIX standard (P1003.1), or
- Access Control Lists, as supported by the POSIX security extension (P1003.1e/2c - previously known as POSIX.6).

A terminal session on the server may be established from the client. This is equivalent to direct Operating System level access. Such connections are limited to those users who have Operating System user accounts.

Any resulting Operating System files (e.g. outputs) will be owned by the ISRA Owner user. However, access for other users may be granted by having default access set for the directory in which the output files are written. In this way wider access may be granted as necessary.

The actual user submitting the batch process will be recorded in the `cdb_activity` table and logged in the Operator log. This allows tracking of processes initiated by specific users.

Batch processes connect to the ISRA database as the Oracle ISRA Owner user. See the following section for more information.

8.2 Oracle Database Tables

Standard Oracle account names and passwords are used for two aspects of system security:

1. To ensure that only valid ISRA users have access to the ISRA system;
2. To assign each ISRA user type with appropriate privileges for Oracle objects such as tables and views.

Users accessing the system from the client will be required to supply an Oracle account name and password to establish a connection to the database running on the server. The Oracle account will be associated with one or more default Oracle roles giving the user access permissions to the tables and the Forms (as described in the following sections).

Note that Oracle account names must be no longer than 8 characters.

Oracle supports the concept of roles which enable access control to be established at the database table level.

Oracle roles are set up with specific table access privileges. Each role having a combination of Create, Read, Update or Delete privileges for each table they have access to.

Each Oracle user is defined as having certain (default) roles. On logging on to the database, the access granted is based on the combination of roles defined (i.e.: the sum of all privileges associated with the default roles).

These access privileges are enforced at database level on all accesses to a table. Thus accesses from Oracle Forms, batch processes and SQL all carry out the same authentication.

The following ISRA user roles are Oracle roles and are defined as default in the ISRA system:

User Role	Description
OPERA	ISRA Operator
OPSUPER	ISRA Operations Supervisor
STANMAN	ISRA Standing Data Manager
AUDI	ISRA Auditor

Table 27: User Accounts, Privileges and Security - Oracle Database Tables

Each user can be assigned one or more of the ISRA roles.

Each ISRA role has a combination of Create, Read, Update or Delete privileges for each table to which the role has been granted access. A user has access to the database tables according to the combined privileges of the assigned roles.

8.3 Oracle Forms Access

Access to Oracle Forms is also controlled by the use of Oracle roles. The concept of menu security for controlling access is applied to Oracle Forms by associating roles with menu items. This allows appropriate functions to be made available to a given role, whilst others will see the menu items as 'greyed out' and not available.

Generally, forms that update the database should only be made available to users who have the necessary privileges on the underlying database tables. However, in some cases the same form will be made available to other users, with only read only access to the underlying tables, to allow data to be viewed. If such users attempt to commit a change, it will be rejected by the underlying database access control restrictions and a message will be displayed to the user indicating that the change has not been made.

8.4 Password Management Through Oracle Profile

The “PROF_SVAA” profile is defined with password management attributes to control access to the system depending on the status of the password. This is assigned to all users created through the Maintain User Oracle form.

8.5 Maintain User

To enable access to the SVAA application software an Oracle user account is required. A new user account can be created either through the Maintain Users Oracle Form or by creating the user manually using below steps:

1. Create a new Oracle account for the user, if the user does not already have one;
2. Assign one or more of the SVAA User Roles to the user, as listed in section 8.2. The user will have access to database tables and Oracle forms according to the combined user roles;
3. Assign the “PROF_SVAA” profile to the user to apply the password management properties.

The Maintain Users Oracle form additionally offers the functionality to control the access on user accounts by changing the password and/or changing the account status to Locked or Unlocked or Expired, also changing the account status to Unexpired which requires a new password to be entered. The Maintain Users Oracle form can also be used to grant and/or revoke the application roles.

An advantage of using the Maintain User form is that user creation, user deletion, and grants and revokes of user roles are audited.

8.6 Breaches of Security

The security features provided by the Operating System control all attempts to logon to the server. These features will be used to monitor and log access to the system.

Access to the Oracle database is controlled using Oracle accounts and roles. Oracle auditing can be used to monitor and log access to the database. In particular, “audit session” can be used to record successful and/or unsuccessful attempts to connect to the database:

```
audit session whenever not successful;
```

Any user attempting to use the AUDIT command must have AUDIT SYSTEM privilege. The Initialisation parameter AUDIT_TRAIL must be set in the database initialisation file to “OS” for the Operating System option. The audit_file_dest parameter needs to be set to the Operating System directory for storage of the audit files.

9 Auditing

Updates to data held in the ISRA database are recorded for audit purposes and for assistance in resolving queries on a day to day basis. Audit records are created following:

- Changes to data via the user interface, such as Profile Classes;
- Changes to data as a result of batch data file processing.

Audit records are created following changes to the following tables:

- CDB_REF_VALUES
- CDB_SYSTEM_PARAMETER
- IDB_AFYCS
- IDB_BM_UNIT_IN_GSP_GROUPS
- IDB_CLOCK_INTERVALS
- IDB_CONSUM_COMP_CLASSES
- IDB_DA_IN_GSP_GROUPS
- IDB_DAILY_PFL_PARAMETERS
- IDB_GSP_GROUP_AVERAGE_EACS
- IDB_NHH_BM_UNIT_ALLOCATION
- IDB_GSP_GROUP_CCTN_SFS
- IDB_GSP_GROUPS
- IDB_LLF_CLASSES
- IDB_MEASUREMENT_REQUIREMENTS
- IDB_MKT_PPT_ROLE_IN_GSP_GROUPS
- IDB_MKT_PPT_ROLES
- IDB_MKT_PPTS
- IDB_PFL_CLASSES
- IDB_PFL_SETS
- IDB_PFLS
- IDB_SETTLEMENT_DAYS
- IDB_SETTLEMENTS
- IDB_SSCS
- IDB_SSR_RUNS
- IDB_TELESWITCH_CONTACT_RULES
- IDB_TSW_CONTACT_INTERVALS
- IDB_TPRS

- IDB_VMR_PFL_CLASSES
- IDB_VSCPCS
- IDB_LLFDATA
- IDB_CKI_DATA
- IDB_SSC_TPR_DATA
- IDB_DEMAND_CONTROL_EVENT
- IDB_DEMAND_CONTROL_INSTRUCTION

and to the idb_user_roles view (only the following changes are audited, and only if they are done via the Maintain User form: adding a new user; dropping a user; granting a role to a user; revoking a role from a user).

Audit data is initially written to a set of database tables, through the use of triggers on the above tables. A batch process, run on a daily basis, writes out the contents of these tables to an audit log. Audit data for the current day can be viewed by initiating a Current Day Audit Report, which directly queries the audit tables.

In addition, if a change is made to Standing Data that has been used in a Final Initial Settlement, (and this can only be performed by the ISRA Standing Data Manager), a Standing Data Audit Report is generated. An example of the human-readable version of this report is given below:

Standing Data Audit Report		ACME Settlements Ltd			28/12/1998 00:21	
User:	Standishm					
User	Date/Time	Entity	Online/Batch Update	Operation	Change Details	
Alexn	1-Apr-1998 00:21	GSP Group	O	Create	GA, Area formerly Eastern, 1-Apr-1998	

Figure 14: Auditing - Standing Data Audit Report

9.1 Audit Database Tables

Audit data is initially written to the database tables `cdb_audit_n` and `cdb_audit_fields_n`. The value of 'n' is between 1 and 7; a separate table is written for each day of the week.

The `cdb_audit_n` table records information about which table has been updated, and the type of update, e.g. deletion, creation. For each record in the `cdb_audit_n` table, the `cdb_audit_fields_n` table records which fields have changed; for creation of a new row and update of a field in an existing row, the values of *all* fields in the row are recorded. If the prime key fields of a row in a table are changed, two audit entries are created in the audit table, a delete entry and a subsequent creation.

Audit information for the current day can be obtained by running a Current Day Audit Report that will query the Audit Database Tables directly.

Each day, a batch process can be run which reads the sets of tables that are not in use, writes out their contents to structured files and deletes the corresponding entries from the audit database tables. To initiate this batch process, execute the following utility from the Operating System command line:

```
isra_submit DMPAUD [@time]
```

where @time is the time at which to perform the task, in the format hhmm. For example,

```
isra_submit DMPAUD @0300
```

The files created by this process are described below.

9.2 Audit Log Files

Audit log files have the following name format:

```
<role code><participant id><9 digit file_id>
```

e.g. for ISR Agent "M001" a file might be named:

```
GM001123456789
```

The location of Audit Log files in the local file store is defined in the `cdb_default_directory` table. The default location for these files is `$RUNTIME/audit/audit_log`.

The audit log files produced are read-only files which can be searched using Operating System tools such as 'grep' and 'vi' to identify all changes made to the database.

The header of the Audit Log identifies the operator of the ISRA system, and the creation time of the Audit Log.

The body of the Audit Log contains the following information:

- **Record Type** - A 3 character code that identifies the audited table. A list of these codes is shown in the table below;
- **Modification Time** - The time at which the auditable change was made;

- **Modification Type** - The type of modification, one of 'C' (Create), 'U' (Update), 'D' (Delete);
- **User** - The user who performed the change to the data. In the case of data changes resulting from batch processes, the user is identified as the ISRA Owner user;
- **Field Value 1** - The first field of the table identified by the Record Type code, which has been subjected to one of the changes identified in Modification Type at the Modification Time by the User;
- **Field Value n** - The nth field of the table identified by the Record Type code, which has been subjected to one of the changes identified in Modification Type at the Modification Time by the User.

The number of Field Values in each record of an lAudit Log depends on the Record Type, i.e. the number of fields in the database table to which that row refers.

The following table shows the possible Record Types for the ISRA system:

Table Name	Record Type
cdb_system_parameter	CSP
cdb_ref_values	CSV
idb_afycs	IAF
idb_bm_unit_in_gsp_groups	IBU
idb_clock_intervals	ICI
idb_consum_comp_classes	ICC
idb_da_in_gsp_groups	IDG
idb_daily_pfl_parameters	IDP
idb_gsp_group_average_eacs	IGE
idb_gsp_group_cctn_sfs	IGC
idb_gsp_groups	IGG
idb_nhh_bm_unit_allocation	INA
idb_llf_classes	ILC
idb_measurement_requirements	IMR
idb_mkt_ppt_role_in_gsp_groups	IMG
idb_mkt_ppt_roles	IMP
idb_mkt_ppts	IMK
idb_pfl_classes	IPC
idb_pfl_sets	IPS
idb_pfls	IPF
idb_settlement_days	ISD
idb_settlements	ISE
idb_sscs	ISC
idb_ssr_runs	ISR
idb_teleswitch_contact_rules	ITR

Table Name	Record Type
idb_tsw_contact_intervals	ITI
idb_tprs	ITP
idb_vmr_pfl_classes	IVP
idb_vscpcs	IVS
idb_user_roles	IUR
<u>idb_llfdata</u>	<u>LLF</u>
<u>idb_cki_data</u>	<u>CKI</u>
<u>idb_ssc_tpr_data</u>	<u>SSC</u>
<u>idb_demand_control_event</u>	<u>DCE</u>
<u>idb_demand_control_instruction</u>	<u>DCI</u>

Table 28: Auditing – Audit Log Files

The following is an example of an audit log.

```
ZHD|L0001001|G|M001|||19970910104204
ISR|19970909154009|I|FAT4OPUS|14403|01-MAR-1998|SF|1|01-MAR-1998|SF|09-SEP-1997|W
ISR|19970909154010|U|ISRAFAT4|14403|01-MAR-1998|SF|1|01-MAR-1998|SF|09-SEP-1997|R
ISR|19970909154010|U|ISRAFAT4|14403|01-MAR-1998|SF|1|01-MAR-1998|SF|09-SEP-1997|R
ISR|19970909154017|U|ISRAFAT4|14403|01-MAR-1998|SF|1|01-MAR-1998|SF|09-SEP-1997|X
ISR|19970909162957|I|FAT4OPUS|14404|02-MAR-1998|R3|1|16-FEB-1998|R3|09-SEP-1997|W
ISR|19970909162959|U|ISRAFAT4|14404|02-MAR-1998|R3|1|16-FEB-1998|R3|09-SEP-1997|R
ISR|19970909162959|U|ISRAFAT4|14404|02-MAR-1998|R3|1|16-FEB-1998|R3|09-SEP-1997|R
ISR|19970909163006|U|ISRAFAT4|14404|02-MAR-1998|R3|1|16-FEB-1998|R3|09-SEP-1997|X
ZPT|10|796461121
```

The first record is the header, identifying the operator of the ISRA system and the creation time of the audit log.

The last record is the footer, which identifies the number of records in the log.

The other records reflect changes to the `idb_ssr_runs` table (denoted by 'ISR'). The second, third and fourth columns identify the time of the change, the type of change (U for update, I for insert) and the user that initiated the change. The remaining columns show the contents of the fields held in the table.

9.3 Audit Appointment Standing Data Changes

The loading of Aggregated HH Data files and Supplier Purchase Matrix files data records can automatically change the standing data for Supplier/GSP Group and DA in GSP Group associations, and the changes are recorded in the table `idb_sup_gsp_da_auto_st_data`. Recording the changes will be controlled so that new entries that are simply an extension of an existing entry will not result in the creation of another separate record, but instead updates the existing record so that the effectiveness date range encompasses the new change. Extensions can occur for any action type, but different types can never be merged together.

When a record in the `idb_sup_gsp_da_auto_st_data` table is created or extended the cleared column will be set to “N”, indicating the details are an ongoing problem. The cleared column will be reset to “Y” when user updates to the standing data, through the Oracle Forms user interface, for Supplier/GSP Group or DA in GSP Group associations overlap the changed effectiveness dates.

The auditing information in the `idb_sup_gsp_da_auto_st_data` table can be listed using the Standing Data Update Report for Suppliers. This report can be produced with reference to an individual Supplier, or for all Suppliers, over a specified timeframe of change dates. The report can be initiated using the Oracle Forms user interface and the following is an example of the machine readable report:

```
ZHD|L0049001|G|M001|||20060113173632
RDT|ISRAFAT7
PR4||20050326|20050326
GSG|W|SDU GSP Group W
SUP|X01|SDU Supplier 01
XDA|U|||20050328|20050328|20050326|20050326|Y
GSG|X|SDU GSP Group X
SUP|X01|SDU Supplier 01
XDA|U|||20050328|20050330|20050326|20050328|N
ZPT|10|862524980
```

The first record is the header which identifying the operator of the ISRA system and the creation time of the report. The second record identifies the user that requested the report and the third record shows the report parameters. The last record is the footer which identifies the number of records in the report.

The other records contain the `idb_sup_gsp_da_auto_st_data` table details. The GSG and SUP groups are used to order information by GSP group and suppliers, and the XDA group provides details of the standing data. The XDA group provides details of:

- Standing data action (either insert or delete);
- DA role code when reporting a DA in GSP Group associations (can be blank);
- DA id when reporting a DA in GSP Group associations (can be blank);

- First settlement date the standing data change applies to;
- Last settlement date the standing data change applies to;
- Earliest date on which this record was modified;
- Latest date on which this record was modified;
- Indicates whether the record has been cleared or not by a manual standing data change.

The location of the machine readable report files in the local file store is defined in the `cdb_default_directory` table. The default location for these files is `$RUNTIME/audit/sdu`.

10 Starting Up and Shutting Down the System

This section describes the steps required to start up and shutdown the ISRA system in a controlled manner. The information given in section 10.1 is also applicable following system failure.

10.1 Starting the System

To start up the ISRA system, log on as the ISRA Owner user, (as set up during installation), and execute the following script from the Operating System command line:

```
isra_start
```

This script starts up the Logging, Scheduler, File Send and File Receipt subsystems.

To check that the system has started correctly, use server operating system functionality to check that the following processes have started correctly:

- Logger (for Operator and Error logs);
- Scheduler;
- File Receipt;
- File Sender.

Note that these processes are owned by the ‘batch’ user that is set up during installation.

For example, if all processes started by `isra_start` have started successfully, running the unix `ps` command:

```
ps -u <ISRA Owner>
```

(where “ISRA Owner” is the user set up during installation of the application software), displays the following type of information:

PID	TTY	S	TIME	CMD
378	??	S	0:03.95	./clgd O
380	??	S	0:04.06	./clgd E
382	??	S	0:16.47	./cscd -f
384	??	S	0:01.91	./cscd -f
386	??	S	0:01.03	./cfrd
388	??	S	0:02.20	./cfsd

where:

- `clgd O` is the logging of Operator Logs;
- `clgd E` is the logging of Error Logs;
- `cscd` is the Scheduler;
- `cfrd` is the File Receipt process;
- `cfsd` is the File Send process.

10.2 Shutting Down the System

To shut down the ISRA system in a controlled way, log on as the ISRA Owner user, (as set up during installation), and execute the following script from the Operating System command line:

```
isra_stop
```

Note that if the ISRA database itself is shut down while users are logged on to the ISRA application software, unusual error messages are displayed via the user interface, e.g. FRM-40735: WHEN-BUTTON-PRESSED trigger raised unhandled exception ORA-04068. The users should log off, and once the database has been restarted, log on again.

11 Monitoring the System

You can use the following to monitor the ISRA system:

- Operator Logs;
- Error Logs;
- Scheduler Logs;
- Data Loading Exception Report;
- Profile Production Exception Report;
- SSR Exception Report;
- Restore Data Exception Report;
- Audit Logs and Standing Data Audit Report;
- Directories.

11.1 Operator and Error Logs

These are human-readable files used to record events and errors. These files are written to via the Logging (CLG) subsystem. Each entry starts with a timestamp created by CLG followed by text that identifies the event or error. A new file is created for each log each day.

The log file names have the following format:

```
OPcurrent_date.LOG
```

```
ERcurrent_date.LOG
```

where `current_date` is the current system date in the format YYYYMMDD. For example, an Operator Log for 1st June 1997 would be named:

```
OP19970601.LOG.
```

The files are allocated file types L0004001 and L0005001 respectively. The location of these files within the ISRA local file store depends on the value of “`directory_id`” in the `cdb_default_directory` table. Refer to section 6.3 for further details about this table.

Messages included in Operator Logs are given in the ISRA Operations Guide. Messages that are included in Error Logs are given in Appendix A of this document. Those messages generated by underlying software such as Oracle that may be shown in the Error Logs, are outside the scope of this document.

An example of part of an Operator Log is given below:

```
08-Sep-1997 18:36:38
```

```
CSC.csc_start_process:Activity 683 started, process identifier is 22601.
```

```
08-Sep-1997 18:36:38
```

```
Load Aggregated Half Hourly Data: Load of GM00112759      started.
```

```
08-Sep-1997 18:36:38
```

```
Load Aggregated Half Hourly Data: Load of GM00112759      successfully completed.
```

```
08-Sep-1997 18:36:38
```

```
CSC.csc_handle_exits:Activity 683 completed, status S, exit status 0.
```

This example shows that an activity with id 683 was started by the Scheduler at 18:36:38. This activity initiated the loading of an Aggregated Half Hourly Data file, with filename GM00112759, which completed successfully.

An example of part of an error log is given below.

```
08-Sep-1997 18:33:03
```

```
Error in idl_common.c, line 1831:
```

```
Supplier M101 and Data Aggregator M302 undefined in idb_da_in_gsp_groups for GSP Group G2  
on Settlement Date 04-Apr-1998 00:00:00.
```

```
08-Sep-1997 18:33:03
```

```
Error in idl_ahhd.c, line 834:
```

```
Record 3, Invalid record type found instead of expected ZPT record.
```

```
08-Sep-1997 18:34:43
```

```
Error in idl_spm.c, line 1474:
```

```
Line Loss Factor Class 3 M102 Unknown in idb_llf_classes.
```

The line numbers refer to the code of a module in the ISRA application software, and may be useful in reporting a problem using error reporting procedures defined by the user organisation.

11.2 Scheduler Logs

The output of all processes handled by the Scheduler is redirected to log files as well as the Operator and Error Logs. These additional log files can be used to monitor batch processes in the event of any failure that prohibits creation of the Operator and Error Logs.

The Scheduler Logs are created in the directory defined in the `cdb_system_parameter` table for the Log Directory system parameter. Scheduler logs have the following filename format:

```
An.pid
```

where `n` is the activity id and `pid` is the process id.

The content of Scheduler Logs is similar to that of Operator and Error Logs.

Note that a record of these log files is *not* held in the `cdb_file_reference` table.

The Log Directory should be periodically cleared of old log files using Operating System tools. The frequency with which this task is performed will depend on the operational environment and operational policy.

11.3 Exception Reports

Exception reports are generated by the Data Loading, Profile Production and SSR subsystems and the Restore Data process if warnings and errors are encountered. They are also generated by the Archive process to record details of the files deleted and counts of records deleted. Further details and examples of these reports are given in the ISRA Operations Guide.

Additionally, if errors are encountered during restore from tape of archived data, an exception report may be generated. The messages contained in this report are listed in Appendix A.

11.4 Data Load Standing Data Update Reports

Data Load Standing Data Update reports are generated when the file load of Aggregated Half Hourly Data, BM Unit Aggregated Half Hour Data or SPM Data causes the ISRA standing data to be updated. Further details and examples of these reports are given in the ISRA Operations Guide. It should be noted that these reports are not accessible in human readable format via the ISRA client. The ISRA system manager must access them via the server.

11.5 Audit Logs and Reports

Audit data is initially written to the database tables `cdb_audit_n` and `cdb_audit_fields_n`. The value of 'n' runs from 1 to 7, such that a separate table is written each day of the week.

Audit data for the current day can be viewed by initiating a Current Day Audit Report, which directly queries the audit database tables.

Each day a batch process is run which goes through the sets of tables that are not in use and writes out their contents to structured files (and deletes the corresponding database entries).

The audit log files produced are read-only files which can be searched using Operating System tools such as 'grep' and 'vi' to identify all changes made to the database. A Standing Data Audit Report is generated if the ISRA Standing Data

Manager makes any changes to Standing Data that has been used in a Final Initial Settlement. An Audit Report is generated for any changes to audited tables. Refer to section 9 for further information about auditing and for an example Audit Log. Refer to Appendix B of the ISRA Operations Guide for an example of an Audit Report.

11.6 Directories

You can check the contents of the directories listed in section 6.1 using standard Operating System functionality. For further information on the naming convention used for files contained in these directories, refer to section 6.2.

12 Archiving

ISRA data relating to settlement days for which Final Reconciliation has been run, and has been retained on the system for a period of time that is longer than that specified by the Data Retention Period system parameter can be archived to tape and deleted from the system. The copying of data to tape is achieved by the daily backup of data.

Archive data can be restored to a database separate from the live database. The restoring of database data is achieved by retrieving data from the archive tape. File data can then be selectively restored on a Settlement Date basis.

Archiving of data from the database and from data files is initiated via the operating system command line.

12.1 Backing Up Data to Off-line Media

Copying data from the Oracle database and flat file store onto off-line media is achieved by a daily backup of data using Operating System functionality. Refer to section 13 for further guidelines on backup.

Archiving of data from the ISRA database and flat file store must be preceded by a successful backup.

The backup that precedes an archive must include the following data:

- The entire Oracle database;
- All internal data files, (prefixed with 'idf' and described in section 6.2), for a specific Settlement Date within the range being archived;
- All input files for a specific Settlement Date within the range being archived;
- All output data files for a specific Settlement Date within the range being archived. Note that for reports, only the data files (stored in the directories under the \$RUNTIME/out/raw directory), rather than the human-readable files (stored in the \$RUNTIME/out/formatted directory) are archived;
- All input data files that do not have a specific Settlement Date associated with them;
- All output data files that do not have a specific Settlement Date associated with them.

12.2 Removing Backed Up Database and File Data

Once data for archiving has been backed up to off-line media, the data can be removed from the Oracle database and flat file store. To perform this housekeeping task, you must be logged on to the Operating System as the ISRA System Manager (ISRA Owner).

To remove the data, use the following utility, which is executed from the command line:

```
iar_archive <archive_date>
```

where:

- <archive_date> is the Settlement Date (in the past) for which data is to be archived. This is in the format DD-MON-YYYY.

Note

The interval (in months) between <archive_date> and the present date must be greater than the Data Retention Period system parameter.

Final Reconciliation must have been performed for <archive_date> and all existing Settlement Dates prior to it.

This utility performs the following:

- Deletes SSR data from the following database tables for Settlement Dates on or before <archive_date>:
 - cdb_data_file;
 - cdb_file_directory;
 - cdb_file_reference;
 - idb_gsp_group_takes;
 - idb_gsp_group_take_revisions;
 - idb_gsp_group_cctn_sf_ssr_runs;
 - idb_pd_sup_purchases;
 - idb_sett_pd_prices;
 - idb_ssa_sett_runs;
 - idb_ssr_run_gsp_groups;
 - idb_ssr_run_gsp_group_pds;
 - idb_ssr_run_llf_files;
 - idb_ssr_runs;
 - idb_sup_data_agtns;
 - idb_sup_data_agtn_in_ssr_runs;
 - [idb_ssa_sett_gsp_groups](#);
 - [idb_demand_control_instruction](#);
 - [idb_demand_control_event](#).
- Deletes Profile data from the following database tables for Settlement Dates on or before <archive_date>:
 - idb_daily_pfl_parameters;
 - idb_pfl_production_runs;
 - idb_teleswitch_intervals;
 - idb_tsw_contact_intervals.
- Deletes Profile Set data from the following database tables for Settlement Dates on or before <archive_date>:

- idb_gsp_group_average_eacs;
- idb_pfl_sets;
- idb_pd_pfl_regr_coefs.
- Deletes Standing data from the following database tables for Settlement Dates on or before <archive_date>:
 - cdb_activity;
 - cdb_activity_parameter;
 - idb_afycs;
 - idb_bm_unit_in_gsp_groups;
 - idb_da_in_gsp_groups;
 - idb_gsp_group_cctn_sfs;
 - idb_llf_classes;
 - idb_nhh_bm_unit_allocation;
 - idb_pfls;
 - idb_settlements;
 - idb_settlement_days;
 - idb_sett_pd_llfs;
 - idb_mkt_ppt_role_in_gsp_groups;
 - idb_vscpcs;
 - idb_vmr_pfl_classes.
- Deletes files from the following directories in the file store that relate to Settlement Dates on or before <archive_date>:
 - received file store;
 - completed file store;
- Deletes the following data files that relate to Settlement Dates on or before <archive_date>:
 - idf_agtd_sup_da_pd_consums;
 - idf_agtd_sup_da_pd_consums_llf;
 - idf_agtn_sup_pd_consums;
 - idf_basic_pd_pfl_coefs;
 - idf_combined_pd_pfl_coefs;
 - idf_pd_pfl_class_coefs;
 - idf_pd_time_pattern_states;
 - idf_pfld_spms;
 - idf_sup_purchase_matrices.

Upon successful completion of archiving an exception report is generated. This exception report details each file removed by archiving, providing the name, directory path location and also the file's id number used to identify the file within the database. A count of the number of rows deleted from each database table is provided, along with a grand total of the number of rows deleted from the database during archiving.

The file name of this exception report is displayed on the screen when archiving completes successfully, to allow the user to find and view the file in the Unix environment if so desired. This file will reside in the `RUNTIME/audit/except` directory.

12.3 Restoring Database Data

To restore archived database data to a non-live database, you need to perform a restore using Operating System and Oracle functionality.

12.4 Restoring Data Files

To restore archived data files from off-line media into the file store of a non-live ISRA system, you need to be logged on to the Operating System as ISRA System Manager.

Primarily, you need to restore the archived database to the non-live database, using Operating System functionality.

To restore the files to the file store of the non-live system, use the following utility, which is executed from the command line:

```
iar_restore <archive_date>  
where:
```

- `<archive_date>` is the Settlement Date for which data is to be restored. This is in the format DD-MON-YYYY.

You are prompted for the name of the tape device name.

An exception report is generated if errors are encountered during the restore. Application messages that may be included in this report are listed in Appendix A.

Operator logs restored from tape will be restored to their state at the time the backup tape was made. This means that any operator log entries written between the backup being taken and the end of that same day will be lost if the backup is restored to the live system. If the full operator log for the day is required to be restored, it should be obtained from the system prior to the restore being performed if it is still online, or from a subsequent backup otherwise.

13 Backup and Recovery

The principal mechanisms for backup and recovery are those provided by the Oracle database and the Operating System. The ISRA system will be protected against hardware failures and corruption by the use of standard system backup and recovery mechanisms.

It is the responsibility of the User organisation to develop a policy for backup of the ISRA database and file store. This section provides guidelines on aspects of such a policy, and discusses the ISRA application software functionality that supports backup and recovery.

13.1 Guidelines on Backup Policy

The main purpose of a backup policy should be to ensure that sufficient data is held off-line to enable recovery of the system in the event of failure. Additionally, backups should be available for restoration of a secondary database to support the requirements of the ISRA Auditor.

A backup policy should ensure that a copy of the database and all external input and output files on the system are written to backup media on a planned basis.

Due to the large size of the ISRA Oracle database, a suggested backup procedure is to perform a full backup at the weekends, and a backup of database redo logs, audit logs and new flat files on a daily basis. The full database backup should include the following:

- All database files;
- All flat files that form part of the database (prefixed with 'idf' and described in section 6.2);
- All input files received within the last 'n' weeks;
- All output and report files sent within the last 'n' weeks;
- Database control files.

where 'n' is determined by the user organisation's backup policy.

The daily backup should include:

- New database flat files (those prefixed by 'idf');
- New input files;
- New output and report files;
- Audit logs (as described in section 9.2);
- Database redo logs (described in section 13.2).

A script, `isra_backup`, that is supplied with the ISRA application software may optionally be used to perform full or incremental backups. The script is stored in the `$RUNTIME/etc` directory, and is executed as shown below. Note that only the ISRA Owner user can execute this script.

To perform a full backup:

```
isra_backup FULL
```

To perform an incremental backup:

```
isra_backup INCR
```

In order to use this script, symbolic links to database files need to be set up manually. For further information, refer to the ISRA Installation Guide.

13.2 Checkpointing

The Oracle database should run in ARCHIVELOG mode. This means that “redo” logs, containing information relating to changes in the database, are automatically copied to an archive area on the disk, enabling recovery of the database. It is assumed that the archive area for holding the redo logs, and the Oracle database tables is on separate media, to ensure that after any single media failure, the database can be recovered using a combination of backups, redo logs and the database itself. Furthermore, if a redo log is lost due to media failure, the database is exposed to any further media failure until the next backup. It may therefore be advisable that the redo logs are duplicated, either using RAID mirroring or Oracle Redo log mirroring.

13.3 Daily Off-line Backups of the ISRA Database

Off-line backups performed during overnight processing should enable the User organisation to:

- Recover the ISRA system following failure;
- Support the requirements of the ISRA Auditor;
- Support the needs of the ISR Agent to archive data from the database.

Results of Settlement runs are required on an occasional basis by the Auditor. For a number of days during the year, the Pool Auditor will require access to all the data for the associated Settlement Runs. To ensure that the Auditor has access to exactly the same set of data that was used in a Settlement Run, locks are set on the database during the Settlement Run. An off-line backup of the database should be performed after Settlement Runs have been performed during end of day processing, to ensure that the Auditor has access to the correct data.

This backup of the ISRA database can also be used to restore the database in the event of failure.

Backup is also the mechanism of storing data off-line prior to deletion of appropriate data from the database using archiving functionality. A successful backup must be performed prior to using the archive functionality provided with the application software. Refer to section 12 for further information about archiving.

13.4 Daily Backups of the ISRA File Store

In addition to the ISRA database, files stored in the ISRA file store should also be backed up daily. A daily incremental backup of the file store may be performed, with an additional full backup periodically. This task is performed using the functionality provided by the Operating System.

13.5 Restoration for Recovery

This section outlines the functionality provided by the ISRA application software that supports recovery of the system in the event of failure.

13.5.1 Recovery from Power Failure

This section outlines recovery after any interruption that causes all active processes to be terminated. For example, as a result of power supply failure or failure of system component.

When the cause of the failure has been identified and rectified and the system is restarted, the Oracle database automatically recovers to the last committed transaction. Any user initiated transactions that had not been committed when the failure occurred are rolled back.

Any file transmissions that were in the progress are repeated. In the case of files being sent, the resend will be carried out automatically by the File Sender (CFS) daemon. For incoming files, the resend will need to be initiated from the Gateway. This will be either by manual request, or through the Gateway detecting that the original transmission did not complete.

13.5.2 Recovery from Fatal Errors

This section outlines recovery after failure to an individual process caused by failure of a hardware component or due to a fatal error during processing. The database is recovered to the state prior to failure, excluding any transactions that were in progress at the time of the failure. Any files that were open are closed.

If one of the batch jobs is interrupted, the job is automatically rescheduled by the Scheduler process.

13.5.3 Recovery from Media (disk) Failure

This section gives an overview of system recovery following a failure of one of the system's disks.

If the failed disk is one of a pair of disks, for example in the use of RAID1, then the system continues functioning normally as the second disk is brought into operation.

If the failed disk is not paired, or if both disks in a pair fail, the possible implications are as follows:

Failure of Database Disks

The database tables affected by the failure can be recovered from backups and redo logs.

Failure of Redo Log Disks

Loss of the redo log disks does not immediately impact the integrity of the system. However, a backup of the database at the earliest opportunity is recommended, to minimise losses resulting from further failures.

File Areas

The effect of loss of these depends on the processing state of the files lost. In most cases this can be determined from the files log (cdb_file_reference, etc) held in the database (which is assumed to be on separate media). However, the most recently arrived files will not yet have been recorded. Thus it may be necessary to check with the Gateway which files have recently been sent.

A range of possible states are considered below:

- In transmission inwards - assume send will be repeated automatically by the Gateway at a later time.
- Received but not processed - file will need to be manually requested for resend from the Gateway or original source. Processing will then be initiated normally.
- Processed but not yet backed up - file only required for audit. If an audit copy is required it can be requested manually from the Gateway or original source.
- Created and not backed up or sent - processing will need to be (manually) repeated to generate file. In some cases (e.g.: audit logs) this recreation may be difficult. Such files are candidates for holding on mirrored media to reduce the risk of loss.
- Backed up - lost files can be restored from backup.
- Sent and not backed up - file is only required for audit. If an audit copy is required it can be requested manually from the Gateway or target system to which it was sent (or processing can be repeated to generate a copy).
- In transmission - the database will not have recorded the transmission completion, therefore when the file is placed back in the send directory (either from backup or by repeat processing) it will be duly sent.

Where a file is permanently lost (i.e. cannot be recovered from another source), it may be useful to update (manually) the database file reference table (`cdb_file_reference`) to show this file's status as "deleted". Thus restoring consistency between the database and file store.

13.5.4 Disaster Recovery

Disaster Recovery procedures need to be developed in line with local policies and procedures. A consideration will be whether recovery would require the use of an alternative machine or alternative site. Recovery is started from the latest backups available.

14 System Management of Application Server

14.1 Remove the Old Report Files

In order to avoid space bottleneck on the Application server, the Old Report files needs to be deleted from the Reports directory at a regular interval.

Note:- Report files should always be deleted in the event of a database import or restore occurring on the database server. This is to prevent later produced report files having the same file name as any reports produced prior to the import/restore. Where such a conflict occurs, only the earlier reports would be visible to the user, which may not contain the expected data.

Appendix A Application Error Messages

This appendix includes exception report messages for the restore task, and error log messages. Note that error messages which can be reported in the Error Log that are not application-specific are not shown.

The messages listed below are grouped under the process in which they could occur. Each message states why the operation or process has been qualified or could not proceed. The cause of the exception and the remedial action required should be self-explanatory in the context of the operation or process that produces the exception.

In some cases, explanatory text has been given to support the listed message.

Further help in diagnosing messages can be sought from the Support Desk.

A.1 Restore Exception Report Messages

The %s annotation used in these messages identify the position of parameters that are added to the messages prior to inclusion in report.

No data files found in database for settlement date %s to restore.

No IDF files found in database for settlement date %s to restore.

No log files found in database for settlement date %s to restore.

File or directory %s not found on tape.

A.2 Error Log Messages

Error log messages have been listed in groups, by subsystem. Messages displayed in the error logs are preceded by a timestamp in the following format:

```
DD-Mon-YYYY HH:MM:SS
```

Text in the following format which precedes some messages can be used to identify the source of a message. This additional text may be used to report errors to a support desk, in accordance with procedures to be defined by the user organisation.

```
Error in <module name>, line <number>
```

In the message descriptions, the “%” symbol is used to indicate that the text at that point is inserted when the message is generated (to give more information about the cause of the condition being reported). “%d” indicates that an integer is inserted (e.g. Aggregation Run Number), while %s indicates that text will be inserted (e.g. a filename). (See a definition of the printf C function for a complete list on the meaning of the characters after the “%” symbol.).

Those messages marked with an asterisk should not normally occur, but if they do, should be reported to the Support Desk.

A.2.1 Archive

```
Failed to run execlp for pax: errno = %d *
```

(‘pax’ is a function that extracts, writes and lists archive files)

```
fork returned error number %d. *
```

(‘fork’ creates a new child process that is identical to the calling parent process)
 pax exited abnormally. *
 (‘pax’ is a function that extracts, writes and lists archive files)
 Memory failure - errno = %d

A.2.2 General Load Data

Cursor open error %d whilst retrieving supplier details
 Cursor fetch error %d selecting suppliers loaded
 Fetch error %d for files omitted from ssr run
 No more records found in data file.
 Record %d: Error in record type. Expected record type: %s.
 Record %d: Error in record format.
 Too many settlement periods %d, greater than max allowed %d.
 Unable to select from user_role_privs *
 Unable to update file status - csl_update_file failed. *
 Error with dates in UNIX
 Fatal Error

A.2.3 Load Aggregated HH Data/ BM Unit Aggregated HH Data

Could not extract ZHD file header from file context buffer.
 Could not extract ZPD additional header from file context buffer.
 Error occurred converting parameter to long integer using strtol function. *
 (‘strtol’ is a function that converts a character string to a specified integer data type)
 Invalid Consumption Component Class, ccc id: %d data agtn type: %s
 Invalid ZHD header in data file.
 Invalid ZPT footer or checksum.
 Oracle error when SELECTing from idb_consum_comp_classes. *
Oracle error when selecting line loss factor class idb_mkt_ppt_roles.*
 Unable to close Aggregated Half Hourly data file. *
 Unable to close the idf_agtd_sup_da_pd_consums flat file. *
 Unable to create idf_agtd_sup_da_pd_consums flat file. *
Unable to create idf_agtd_sup_da_pd_consums llf flat file.*
 Unable to create new record for SPC - csl_new_record failed. *
 Unable to get record type from file context buffer.
 Unable to open data file. *
 Unable to read record type from file context buffer.
 Unable to write aggregated supplier consumption/line loss for period %d. *
 Unable to write consum_comp_class_id field of SPC record. *
Unable to write mkt_ppt_id field of SPC record.*
Unable to write llf_class_id field of SPC record.*
 Unable to write da_hh_msid_count field of SPC record. *

Unable to write settlement period count field of SPC record. *

Unable to write SPC record to idf file. *

Unable to write supplier_id field of SPC record. *

Unable to write ZHD header to idf_agtd_sup_da_pd_consums flat file. *

Unable to write ZHD header to idf_agtd_sup_da_pd_consums llf flat file. *

%s format is not valid for Settlement Dates before the start of NETA.

File contains data in both %s and %s formats.

File for pre-NETA Settlement Day %s must be in %s format, but %s format found.

Unable to open cursor to read BM Units.

Oracle error occurred while FETCHing from bm_unit_in_gsp_groups.

Could not close cursor bm_units_cursor.

Unable to write bm_unit_id field of SPC record.

Unable to open cursor to read Default BM Units.

Unexpected number of rows affected by statement, %d

A.2.4 Load BM Unit Registration Data

Unable to close BM Unit Registration data file.

NETA Start Date parameter, %s, must be in %s format.

Unexpected record type found

Failed to fetch rows for cursor on idb_bm_unit_id_gsp_groups.

Failed to open cursor on idb_bm_unit_in_gsp_groups.

Failed to open cursor get_gsp_suppliers on idb_bm_unit_id_gsp_groups.

Failed to open cursor get_default_bm_units on idb_bm_unit_id_gsp_groups.

Failed to fetch rows for cursor get_default_bm_units on idb_bm_unit_id_gsp_groups.

Failed to fetch rows for cursor get_gsp_suppliers on idb_bm_unit_id_gsp_groups.

Failed to open cursor get_bmu_id on idb_bm_unit_id_gsp_groups.

Failed to fetch rows for cursor get_bmu_id on idb_bm_unit_id_gsp_groups.

Failed to open cursor get_bmu_instance on idb_bm_unit_id_gsp_groups.

Failed to fetch rows for cursor get_bmu_instance on idb_bm_unit_id_gsp_groups.

Failed to fetch rows for cursor get_bmu_id on idb_bm_unit_id_gsp_groups.

Failed to open cursor get_ibu_records on idb_bm_unit_id_gsp_groups.

Failed to fetch cursor get_ibu_records.

A.2.5 Load GSP Group Take

CDCS extract number in database and data file are different.

Could not extract ZHD file header from file context buffer.

Could not extract ZPD additional header from file context buffer.

Could not read HDR gsp group take header from data file.

Current record is not a GSP Group Take Details (GSP) record.

Error occurred converting parameter to long integer using strtol function. *

(‘strtol’ is a function that converts a character string to a specified integer data type)

Invalid ZHD header in data file.

Invalid ZPT footer or checksum.

Sett_run_type_id in data files is different to that in the database.

Unable to close GSP Group Take data file.

Unable to open data file.

Unable to read record type from fileContext buffer.

Oracle error occurred SELECTing FROM cdb_system_parameter.

Sending SSA Market Participant defined in file header (%s) not as expected (%s).

A.2.6 Load Line Loss Factor Data

%s: Expected Footer record not found.

%s: Unable to close Line Loss Factor data file. *

%s: Unable to convert settlement date into time. erro no = %d

%s: Unable to determine record type.

%s: Unable to extract settlement_date from file context buffer

%s:Insert into idb_sett_pd_llfs failed. *

%s:Select from dual failed. *

(‘dual’ is a dummy Oracle table containing sysdate, user name etc.)

%s:Unable to determine if the distributor %s is known.

%s:Unable to log classes missing from file.

Unable to convert file creation date into time.

Unable to convert latest loaded date into time.

Unable to delete previously failed load data.

Unable to determine latest loaded file.

Unable to select from dual *

A.2.7 Load Market Domain Data

Could not extract ZHD file header from file context buffer.

Could not extract ZPD additional header from file context buffer.

Error occurred converting parameter to long integer using strtol function. *

(‘strtol’ is a function that converts a character string to a specified integer data type)

Invalid ZHD header in data file.

Invalid ZPT footer or checksum.

Unable to close Pool Market Domain data file. *

Unable to open data file.

Unable to select from dual

Unable to update idb_afycs *

Record %d, SCC Type changed for SSC id: %s. This may cause any SSR re-runs to produce different results.

Record %d, SCC Id: %s has invalid type of %s. Must be I or E.

A.2.8 Load Profile Data

Error file with id %f does not exist
 Error reading file id
 Error reading filename from cdb_file_reference
 Error validating file %s
 Incorrect number of input arguments
 Unable to convert file creation date into time
 Unable to convert latest loaded date into time.
 Unable to determine latest loaded file

A.2.9 Load Regression Equation Data

Error file with id %f does not exist
 Error reading coefficient types from cdb_ref_values
 Error reading file id
 Error reading filename from cdb_file_reference
 Error validating file %s
 Incorrect number of input arguments
 Unable to convert file creation date into time
 Unable to convert latest loaded date into time.
 Unable to determine latest loaded file

A.2.10 Load Settlement Price Data

Could not extract ZHD file header from file context buffer.
 Could not extract ZPD additional header from file context buffer.
 Error occurred converting parameter to long integer using strtol function. *
 ('strtol' is a function that converts a character string to a specified integer data type)
 Incorrect number of SPP records %d read from file.
 Invalid ZHD header in data file.
 Invalid ZPT footer or checksum.
 Load Data is same or earlier version than previously loaded.
 Sett_run_type_id in data files is different to that in the database.
 Unable to close settlement price data file.
 Unable to open data file.
 File cannot be loaded for Settlement Date %s, which is after the NETA Start Date.

A.2.11 Load Scottish Regression Equation Data⁵

Error file with id %f does not exist
 Error reading coefficient types from cdb_ref_values
 Error reading file id
 Error reading filename from cdb_file_reference

⁵ Loading of this data is disabled as a result of LCR235.

Error validating file %s
 Incorrect number of input arguments
 Unable to convert file creation date into time
 Unable to convert latest loaded date into time.
 Unable to determine latest loaded file

A.2.12 Load Sunset Data

Error getting File name for file id %lf
 Error reading header from %s
 Error validating checksum of file %s
 Error validating header of file %s
 Nonexisting file id
 Unable to retrieve system parameter SYS/MKR
 Unable to retrieve system parameter SYS/PID

A.2.13 Load Supplier Purchase Matrix Data

Could not extract ZHD file header from file context buffer.
 Could not extract ZPD additional header from file context buffer.
 Error occurred converting parameter to long integer using strtol function. *
 ('strtol' is a function that converts a character string to a specified integer data type)
 Invalid ZHD header in data file.
 Invalid ZPT footer or checksum.
 Unable to close supplier purchases matrix data file. *
 Unable to close the idf_sup_purchase_matrices file. *
 Unable to close the idf_sup_purchases_matrix flat file. *
 Unable to create DAT record - csl_new_record failed. *
 Unable to create new idf_sup_purchase_matrices data file. *
 Unable to create new record for SUP - csl_new_record failed. *
 Unable to open data file.
 Unable to write DAT record to idf file. *
 Unable to write distributor_id. *
 Unable to write llf_class_id. *
 Unable to write profile_class_id. *
 Unable to write spm_def_eac_msid. *
 Unable to write spm_def_unmetered_msid. *
 Unable to write spm_total_aa. *
 Unable to write spm_total_aa_msid. *
 Unable to write spm_total_eac. *
 Unable to write spm_total_eac_msid. *
 Unable to write spm_total_unmtd_consum. *
 Unable to write spm_total_unmtd_msid. *

Unable to write ssc_id. *

Unable to write SUP record to idf spm flat file. *

Unable to write supplier_id field of SUP record. *

Unable to write tpr_id. *

Unable to write ZHD file header to idf_sup_purchase_matrices file. *

Unexpected error code %d found. *

Unable to open cursor to read Default BM Units.

Unexpected number of rows affected by statement, %d

Duplicate SPM found in File %.Of GSP %s DA %s Sett Date %s Sett Code %s Supp %s
LLFC %d Dist %s SSC %s TPR %s PC %d

A.2.14 Load Tele-switch Contact Interval Data

There are no contact intervals defined for User %d, Group %d, data file rejected

Could not extract ZHD file header from file context buffer.

Could not retrieve clock_change information for date: %s. *

Could not retrieve previous clock-change information for date: %s

Error occurred reading Tele-switch Date data. *

Error occurred reading Tele-switch Date data

Error occurred reading TSW file id from parameters.

Failed to allocate memory for contact intervals array. *

Failed to allocate memory for valid user groups array. *

Failed to allocate next block of memory for tsci_data. *

Failed to allocate next block of memory for valid user groups. *

Failed to open cursor ts_user_group_cur. *

Incorrect parameters. idl_tsw syntax: idl_tsw <file_id> [-d]. *

Invalid ZPT footer or checksum

Oracle error %d occurred selecting from idb_ssr_runs for date: %s. *

Oracle error %d occurred selecting user group data from idb_sscs for sett_date:%s. *

Oracle error(%d) occurred inserting into idb_tsw_contact_intervals for or after user:%d;
group:%d; contact:%s start:%s. *

Oracle error %d occurred determining interval end time for start date time:%s. *

Oracle error: %d occurred selecting from idb_sscs for user: %d. *

Oracle error: %d occurred when determining previous clock change information for date:
%s from idb_settlement_days. *

Oracle error: %d: occurred deleting contact intervals for date: %s. *

Oracle error: %d: occurred retrieving day after Tele-switch date: %s. *

Oracle error:%d: occurred when deleting from idb_tsw_contact_intervals for Tele-switch
start date%s. *

Record %d, Duplicate start times of %s for teleswitch date %s, user %d, group %d, contact
code %s.

Unable to close Tele-switch Contact Interval data file. *

Unable to open data file. *

A.2.15 FTP Fetch Tele-switch Contact Interval Data

Load Tele-switch Contact Switching Times Data: Load of %s completed with status %d.

Load Tele-switch Contact Switching Times Data: Load of %s started.

Tele-switch Contact Interval Data file Collection: Collected %s successfully.

Tele-switch Contact Interval Data file Collection: Collecting %s

Tele-switch Contact Interval Data file Collection: Error: bad date format

Tele-switch Contact Interval Data file Collection: Error: Cannot find an appropriate input directory (from db: "") to receive %s.

Tele-switch Contact Interval Data file Collection: Error: Format error in file %s.

Tele-switch Contact Interval Data file Collection: Error: FTP failed, see e-mail sent to SVAA 2nd line %s

Tele-switch Contact Interval Data file Collection: Error: timeout of FTP get for %s after 60 seconds.

Tele-switch Contact Interval Data file Collection: Error: %s already awaiting receipt in /home/users/svaport/runtime/in/new.

Tele-switch Contact Interval Data file Polling: Error: FTP failed, see e-mail sent to SVAA 2nd line %s.

Tele-switch Contact Interval Data file Polling: Error: timeout of FTP directory listing after 60 seconds.

A.2.16 Profile Production

Bad parameters given

Cannot calculate day info as previous clock-change day is not a clock change day!

Cannot extract settlement date from path %s (dir. Id%d)

Could not extract header from time-pattern states file

Could not get record type

Could not read header of time-pattern states file

Create output file returned error %d

Error in copying record

Error in deleting file %s%s.dat

Error in deleting temporary %s file. Continuing anyway

Error in exporting file

Error in reading time-pattern file record

Error in writing file footer *

File %0.f could not be read

File id %0.f has NULL directory path. Open failed.

GSP group id too long

Header of file %0.f could not be extracted

Incorrect number of input arguments

interval_list malloc error.*

Invalid GSP group id

Invalid GMT/Local Time indicator for Time Pattern Regime %s

Invalid list of GSP groups. Must begin with a '.'

Malloc error *

No GSP groups in list

No time-pattern states in file

Open exception file %li returned error %d

Open input file %.0f returned error %d

Oracle Error %d %s *

Oracle error in converting date using Oracle, error *

Oracle error in fetching cursor mkt_ppt_roles. Error %d *

Oracle error in opening cursor mkt_ppt_roles. Error %d *

Oracle error in selecting exception file_id from cdb_file_reference, %d *

Oracle error in selecting from cdb_activity, %d *

Oracle error in selecting from cdb_file_reference. Error %d *

Oracle error in selecting from dual. Error %d *

Oracle error in selecting path from cdb_file_directory. *

Oracle error in selecting sysdate from dual. Error %d *

Oracle error selecting from idb_settlement_days %d *

period_tps_new malloc error *

realloc error *

round down duration calloc error. *

round up duration calloc error. *

Specified file_id (%s) is wrong format.

spot_times calloc error. *

Time-pattern file could not be closed *

Time-pattern states file could not be closed *

Too many GSP groups have been listed. Maximum 20

Too many gsp groups - maximum of 20 allowed

Unable to allocate memory for GSP group *

Unable to allocate memory for gsp_group_list *

Unable to allocate memory for GSP group list *

Unable to allocate memory for on-state indicators *

Unable to allocate memory for time-pattern state *

Unable to close input file *

Unable to close output file *

Unable to create output file *

Unable to create tps.dat file *

Unable to delete required files, so cannot continue

Unable to delete tpr.dat file

Unable to extract data header

Unable to fetch from cursor mkt_ppt_roles. Error %d

Unable to find activity %s in cdb_activity table *

unable to obtain market participant or role code from cdb_system_parameter *

Unable to open cursor mkt_ppt_roles. Error %d *

Unable to open input file %0.f *

Unable to open time-pattern states file for date %s *

Unable to read %s record from input file %.0f.

Unable to retrieve SSCs for TPR %s.

Unable to retrieve system parameter SYS/MKR

Unable to retrieve system parameter SYS/PID

Unable to select number_records from cdb_file_reference for file_id %d. Error = %d

Unable to update exception file status - csl_update_file failed. *

Unable to update file status - csl_update_file failed. *

Unable to write data header *

Unable to write file header *

Unable to write header to output file

unrounded_duration calloc error. *

Wrong file type for given file_id.

Wrong number of arguments %d

Unexpected Oracle error 1403 in idp_dpp_run.c, line %d: selecting previous clock-change from idb_settlement_days. Date= %s

Unexpected Oracle error 1403 in idp_pr_tci.c, line %d: selecting previous clock-change from idb_settlement_days. Date= %s

Error with dates in Unix

Unable to get date from csl_get_next_day

Unable to get date from csl_local_datetime

A.2.17 Data Aggregation and Settlement Timetable

Error occurred reading SETT_CAL file id from parameters.

Incorrect parameters. idl_sett_cal syntax: idl_sett_cal <file_id> [-d].

Unable to open data file.

Invalid ZPT footer or checksum.

Invalid ZHD header in data file.

Unable to determine latest loaded file.

Unable to convert latest loaded date into time.

Unable to convert file creation date into time.

Unable to close Data Aggregation and Settlements Timetable File.

Unable to read record type from fileContext buffer.

Error occurred reading Timetable Header data.

Error occurred reading Settlement Timetable data

Could not extract ZHD file header from file context buffer.

Failed to determine list of valid Settlement Codes.

No valid Settlement Codes retrieved from idb_sett_types.
 Could not retrieve valid Settlement Codes from idb_sett_types.

A.2.18 Market Domain Data Complete Set

Error occurred reading Market Domain Data Complete Set file id from parameter list.
 Incorrect parameters. idl_mcs syntax: idl_mcs <file_id> [-d].
 Unable to open data file.
 Invalid ZPT footer or checksum.
 Invalid ZHD header in data file.
 Could not extract ZHD file header from file context buffer.
 Failed to select from cdb_ref_values for day_type_id.
 Failed to select from cdb_ref_values for season_id.
 Oracle error %d occurred selecting from cdb_file_reference.
 Failed to fetch rows for cursor on idb_settlement_days.
 Failed to open cursor on idb_settlement_days.
 Failed to fetch rows for cursor on idb_llf_classes.
 Failed to open cursor on idb_llf_classes.
 Unable to read next record from data file.
 Failed to fetch rows for cursor on idb_mkt_ppt_role_in_gsp_groups.
 Failed to open cursor on idb_mkt_ppt_role_in_gsp_groups.
 Failed to select from cdb_ref_values.
 Unable to close Market Domain Data Complete Set file.

A.2.19 SSR

Failed to wait for activities %s. *
 Invalid argument %s ignored
 Invalid option %c ignored
 Memory failure - errno = % *
 Open exception file %li returned error %d *
 Unable to update exception status - csl_update_file failed. *
 Default BM Units errors found for Settlement Date %s.
 Oracle error occurred SELECTing FROM cdb_system_parameter.
 NETA Start Date parameter, %s, must be in %s format.
 Unable to select GSP Group Correction Factor for CCC %d

A.2.20 Reports

The following error messages are included for reports such as TUoS Report, NHHDA Operational Performance Report, Audit Report. Each report process may generate a subset of these messages.

%s: Changes for Audit Id %ld lost. Maximum size (%d) of Change Details field exceeded

%s: Maximum size of Change Details (%d) exceeded.

%s: Maximum size of single change details (%d) exceeded.

"%s: More %s codes exist in cdb_ref_values than loaded.

%s: No Change Details found for audit id %ld.

%s: Table Name for code %s NOT found in table array. *

%s: Truncation of Change Details occurred for audit id %ld. Maximum size (%d) exceeded.

%s: Unable to close audit log file. *

%s: Unable to convert End date into time. error no = %d

%s: Unable to convert modification date into time. Error no = %d

%s: Unable to convert Start date into time. erro no = %d

%s: Unable to create %s record for audit report. *

%s: Unable to create %s record. *

%s: Unable to determine record type.

%s: Unable to extract Modification Type from file context buffer

%s: Unable to extract Username from file context buffer

%s: Unable to read field information.

%s: Unable to read first record from Audit file.

%s: Unable to read record from Audit file.

%s: Unable to update file status - csl_update_file failed. *

%s: Unable to write %s record for audit report. *

%s: Unable to write %s record. *

%s: Unable to write audit entity field for %s record. *

%s: Unable to write Audit Operation for %s record. *

%s: Unable to write Batch/Online field for %s record. *

%s: Unable to write Change Details field for %s record. *

%s: Unable to write Change Details for %s record. *

%s: Unable to write Date/Time of Change field for %s record. *

%s: Unable to write end date field for %s record. *

%s: Unable to write entity field for %s record. *

%s: Unable to write Entity Name for %s record. *

%s: Unable to write File Footer record. *

%s: Unable to write Online/Batch Indicator for %s record. *

%s: Unable to write Operation Type field for %s record. *

%s: Unable to write report username field for %s record. *

%s: Unable to write start date field for %s record. *

%s: Unable to write username field for %s record. *

%s: Unable to write warning field for %s record. *

%s: Unable to write ZHD record for audit report. *

Bad input parameters

Bad input params argc %d ssr_run %ld

Bad parameters argc %d, ssr_run %ld
Call to csl routine failed, status %d
Call to isl_open_file failed, status %d
Call to malloc () failed
CCC %d out of range
CCC ID %d out of range
CSL call failed status: %d *
csl error %d *
CSL error creating Operational Performance report
csl error status %d *
CSL error unable to retrieve market participant id
CSL error unable to retrieve market participant role code
CSL failure %d *
csl write error %d *
CSL wrong report parameter value
Cursor call failed *
Cursor call error *
Cursor open error %d whilst retrieving missing files
Cursor open error %d whilst retrieving omitted files
Cursor open error %d whilst retrieving used files
Date convention failure: date %s ora status: %d *
dtk call failed status: %d *
dtk parameters invalid *
DUoS processing error %d
dus call failed status: %d *
dus parameters invalid *
ebr call failed status: %d *
ebr parameters invalid *
error %d fetching cursor for ssr runs
Error %d selecting from cdb_activity
error %d selecting from dual*
Error %d selecting from idb_mkt_ppts
Error %d selecting from idb_gsp_groups
Error %d selecting from reference values
error categorising CCCs %d *
error in write to MRO %d *
error opening aspc %d *
Error opening aspc file %d *
error opening idf file %d *
error reading asdpc %d *

error reading aspc %d *
Error reading idf_asdpc %d *
Error totalling DA figures %d *
Error writing to MRO status: %d *
Failed read/writing values %d *
Failed reading SPM status: %d *
Failed selecting from idb_mkt_ppts *
Failed to extend array %d *
Failed to malloc memory *
Failed to select from idb_ssr_run_gsp_groups *
Failed to submit %s to scheduler
Failed to write to MRO error %d
Fetch error %d for files missing from ssr run
Fetch error %d for files omitted from ssr run
Fetch error %d for files used in ssr run
gct call failed status: %d *
gct failed with bad input params
hhd call failed status: %d
hhd failed with bad input params
Internal CCC Id error *
Invalid input params argc: %d *
Invalid input params argc %d start date %s end date %s *
Invalid parameters argc %d start date %s end date %s *
Invalid params argc %d ssr %ld supp %s *
Invalid Params argc %d ssr_run %ld *
Invalid params argc %d start date %s end date %s *
Invalid params argc %d, ssr_run_number %ld *
Invalid params to spf_get_pricings *
ISL call failed status: %d *
isl open file error %d *
isl read PSPM memory error %d *
isl read SPM error %d *
Malloc fail - status: %d *
Malloc () failed to allocate memory *
Missing schema owner system parameter, SYS_SCO
PFD_ procedure error %d *
processing error in spf_sup ().
read aspc error %d *
Read PSPM error %d *
read SPM error %d *

SBU failed with status: %d", status
 SC deemed take calculation error %d *
 spf_get_consums error reading ASPC file *
 SPF_procedure error %d *
 SPF call failed status: %d *
 SSH call failed status: %d *
 ssr call failed status: %d *
 sup call failed status: %d *
 TUS_ procedure error %d *
 Unable to select from dual. *
 Unable to select from dual. Error %d *
 Unable to select from settlements data error %d
 Unable to update file status - csl_update_file failed. *
 Unable to write SSR record: status %d *
 Unable to write CON record: status %d *
 vas_con called with bad parameters *
 vas_details call failed status: %d *
 vas_rdt call failed status: %d *
 vas_ssr called with bad parameters *
 vas_upd_totals called with bad_parameters *
 vas_con call failed status: %d *
 vas_ssr call failed status: %d *
 vas_upd_totals call failed status: %d *
 vas_details processing error *
 Writing MRO error %d *
 Error with dates in Unix
 Error getting last day in February
[Read PDPM error %d *](#)
[read DPM error %d *](#)

A.2.21 Exception Reports

Attempt was made to re-initialise the open exception log file.
 Cannot create exception log file *
 Could not create exception detail record *
 Unable to close exception log file. File already closed. *
 Unable to close the exception log file *
 Unable to close the exception log file before deletion. *
 Unable to delete the exception log file *
 Unable to update file status - csl_update_file failed. *
 Unable to write exception text to exception log file *

Unable to write exception to exception log file *

Unable to write exception to log file. Log file is closed. *

Unable to write exception type to exception log file *

Unable to write HDR file header to exception log file *

Unable to write XHD header to exception log file *

Unable to write XPD header to exception log file *

Unable to write ZHD file header to exception log file *

Unable to write ZPD file header to exception log file *

Unable to write ZPT footer to exception log file. Deleting log file. *

A.2.22 Data Load Standing Data Update Reports

Attempt was made to re-initialise the open update log file.

Cannot create update log file *

Could not create update detail record *

Unable to close update log file. File already closed. *

Unable to close the update log file *

Unable to close the update log file before deletion. *

Unable to delete the update log file *

Unable to update file status - csl_update_file failed. *

Unable to write update text to update log file *

Unable to write update to update log file *

Unable to write update to log file. Log file is closed. *

Unable to write HDR file header to update log file *

Unable to write XHD header to update log file *

Unable to write XPD header to update log file *

Unable to write ZHD file header to update log file *

Unable to write ZPT footer to update log file. Deleting log file. *

A.2.23 Load LLF/SSC Mapping Data

Unable to open data file.*

Load %s: Load of %s failed with status %d.*

Unable to close LLF SSC mapping data file. *

The %s file type must contain at least 1 LLF record after ZHD record.*

Unable to update record into IDB_SSC_TPR_DATA.*

Unable to delete record into IDB_CKI_DATA.*

Unable to insert record into IDB_SSC_TPR_DATA.*

Unable to insert record into IDB_CKI_DATA.*

Unable to close the Data mapping file. *

Unable to write Line Loss Factor Class Id of LLF record.*

Unable to write Standard Settlement Configuration Id of LLF record.

Unable to write Standard Settlement Configuration Id of SSC record.*

Unable to write Standard Settlement Configuration Desc of SSC record.*

Unable to write Effective from Settlement Date SSC of SSC record.*

Unable to write Effective to Settlement Date SSC of SSC record.*

Unable to write Standard Settlement Configuration Type of SSC record.*

Unable to write Day of the Week Id of CKI record.*

Unable to write Start Month of CKI record.*

Unable to write End Day of CKI record.*

Unable to write End Month of CKI record.*

Unable to write Start Time of CKI record.*

Unable to write End Time of CKI record.*

A.2.24 Load BM Unit Aggregated HH Demand Disconnection Data

Could not extract ZHD file header from file context buffer.

Could not extract ZPD additional header from file context buffer.

Error occurred converting parameter to long integer using strtol function. *

('strtol' is a function that converts a character string to a specified integer data type)

Invalid Consumption Component Class, ccc id: %d data agtn type: %s

Invalid ZHD header in data file.

Invalid ZPT footer or checksum.

Oracle error when SELECTing from idb_consum_comp_classes. *

Unable to close Aggregated Half Hourly data file. *

Unable to close the idf_agtd_sup_da_pd_consums flat file. *

Unable to create idf_agtd_sup_da_pd_consums flat file. *

Unable to create new record for SPC - csl_new_record failed. *

Unable to get record type from file context buffer.

Unable to open data file. *

Unable to read record type from file context buffer.

Unable to write aggregated supplier consumption/line loss for period %d. *

Unable to write consum_comp_class_id field of SPC record. *

Unable to write da_hh_msid_count field of SPC record. *

Unable to write settlement period count field of SPC record. *

Unable to write SPC record to idf file. *

Unable to write supplier_id field of SPC record. *

Unable to write ZHD header to idf_agtd_sup_da_pd_consums flat file. *

%s format is not valid for Settlement Dates before the start of NETA.

File contains data in both %s and %s formats.

File for pre-NEEA Settlement Day %s must be in %s format, but %s format found.

Unable to open cursor to read BM Units.

Oracle error occurred while FETCHing from bm_unit_in_gsp_groups.

Could not close cursor bm_units_cursor.

Unable to write bm_unit_id field of SPC record.

Unable to open cursor to read Default BM Units.

Unexpected number of rows affected by statement, %d

A.2.25 Load Disconnection Purchase Matrix Data

Could not extract ZHD file header from file context buffer.

Could not extract ZPD additional header from file context buffer.

Error occurred converting parameter to long integer using strtol function. *

('strtol' is a function that converts a character string to a specified integer data type)

Invalid ZHD header in data file.

Invalid ZPT footer or checksum.

Unable to close disconnection purchases matrix data file. *

Unable to close the idf_discon_purchase_matrices file. *

Unable to close the idf_discon_purchases_matrix flat file. *

Unable to create DAT record - csl_new_record failed. *

Unable to create new idf_discon_purchase_matrices data file. *

Unable to create new record for SUP - csl_new_record failed. *

Unable to open data file.

Unable to write DAT record to idf file. *

Unable to write distributor_id. *

Unable to write llf_class_id. *

Unable to write profile_class_id. *

Unable to write dpm_def_eac_msid. *

Unable to write dpm_def_unmetered_msid. *

Unable to write dpm_total_aa. *

Unable to write dpm_total_aa_msid. *

Unable to write dpm_total_eac. *

Unable to write dpm_total_eac_msid. *

Unable to write dpm_total_unmtd_consum. *

Unable to write dpm_total_unmtd_msid. *

Unable to write ssc_id. *

Unable to write SUP record to idf_dpm_flat file. *

Unable to write supplier_id field of SUP record. *

Unable to write tpr_id. *

Unable to write ZHD file header to idf_sup_purchase_matrices file. *

Unexpected error code %d found. *

Unable to open cursor to read Default BM Units.

Unexpected number of rows affected by statement, %d

A.2.26 Load Demand Control Event Data

Could not extract ZHD file header from file context buffer.
Could not extract ZPD additional header from file context buffer.
Invalid ZHD header in data file.
Invalid ZPT footer or checksum.
Unable to close demand control event data file. *
Unable to create DAT record - csl_new_record failed. *
Unable to create record in the table idb_demand_control_event
Unable to select record from the table idb_demand_control_event
Unable to open data file.
Unable to write dce_id. *
Unable to write dce_start_date. *
Unable to write dce_end_date. *
Unable to write dce_msi. *
Unexpected error code %d found. *

A.2.27 Load Demand Control Instructions Data

Could not extract ZHD file header from file context buffer.
Could not extract ZPD additional header from file context buffer.
Invalid ZHD header in data file.
Invalid ZPT footer or checksum.
Unable to close demand control instructions data file. *
Unable to create DAT record - csl_new_record failed. *
Unable to create record in the table idb_demand_control_instruction
Unable to select record from the table idb_demand_control_event_instruction
Unable to open data file.
Unable to write dci_id. *
Unable to write dci_start_date. *
Unable to write dci_end_date. *
Unable to write dci_volume. *
Unexpected error code %d found. *

A.2.28 Load Disconnected MSIDs and Estimated Half Hourly Demand Disconnection Volumes

Could not extract ZHD file header from file context buffer.
Could not extract ZPD additional header from file context buffer.
Invalid ZHD header in data file.
Invalid ZPT footer or checksum.
Unable to close Disconnected MSIDs and Estimated Half Hourly Demand Disconnection

Volumes data file. *

Unable to create DAT record - csl_new_record failed. *

Unable to write DCE id of DCE record

Unable to write start date of DCE record

Unable to write end date of DCE record.

Unable to write standard settlement configuration id

Unable to write MSID of MSI record

Unexpected error code %d found. *

A.3 Data Load Standing Data Update Report Messages

Record %d, No Data Aggregator/GSP Group association for Supplier %s, Data Aggregator %s and GSP Group %s, existing association extended to settlement day

Record %d, No Data Aggregator/GSP Group association for Supplier %s, Data Aggregator %s and GSP Group %s, association added on settlement day

No data provided for Supplier %s in data file from Data Aggregator %s for GSP group %s, association removed for settlement day

Aggregated Half Hourly data file received from unexpected Data Aggregator %s for GSP Group %s, existing association extended to settlement day

Aggregated Half Hourly data file received from unexpected Data Aggregator %s for GSP Group %s, association will be added on settlement day

Supplier Purchase Matrix data file received from unexpected Data Aggregator %s for GSP Group %s, existing association extended to settlement day.

Supplier Purchase Matrix data file received from unexpected Data Aggregator %s for GSP Group %s, association will be added on settlement day.