

Redlined BSCP01 text for CP1426 ‘Receipt of the D0296 flow at II’

This CP proposes changes to Sections 1.5, 3.3, and 4.1 of BSCP01. We have redlined these changes against Version 14.0.

There is no impact on any other part of this document for this CP.

Amend Section 1.5 as follows:

1.5 Associated BSC Procedures

The following is a list of BSCPs covering activities and interfaces that are dependent on the Settlement timetable:

BSCP03	Data estimation and substitution for CVA
BSCP04	BM Unit Metered Volumes for Interconnector Users
BSCP11	[Housekeeping]Trading Queries and Trading Disputes
BSCP65	Registration of BSC Parties and Exit Procedures
BSCP68	Transfer of Registration of metering systems between CMRS and SMRS
BSCP71	Submission of ECVNs and MVRNs
BSCP301	Clearing, Invoicing and Payment
BSCP501	Supplier Meter Registration Service
BSCP502	Half Hourly Data Collection for Metering Systems Registered in SMRS
BSCP503	Half Hourly Data Aggregation for Metering Systems Registered in SMRS
BSCP504	Non Half Hourly Data Collection for Metering Systems Registered in SMRS
BSCP505	Non Half Hourly Data Aggregation for Metering Systems Registered in SMRS
BSCP508	Supplier Volume Allocation Agent
BSCP514	SVA Meter Operations for Metering Systems Registered in SMRS

Amend Section 3.3 as follows:

3.3 Interim Information and Initial Volume Allocation / Settlement Runs

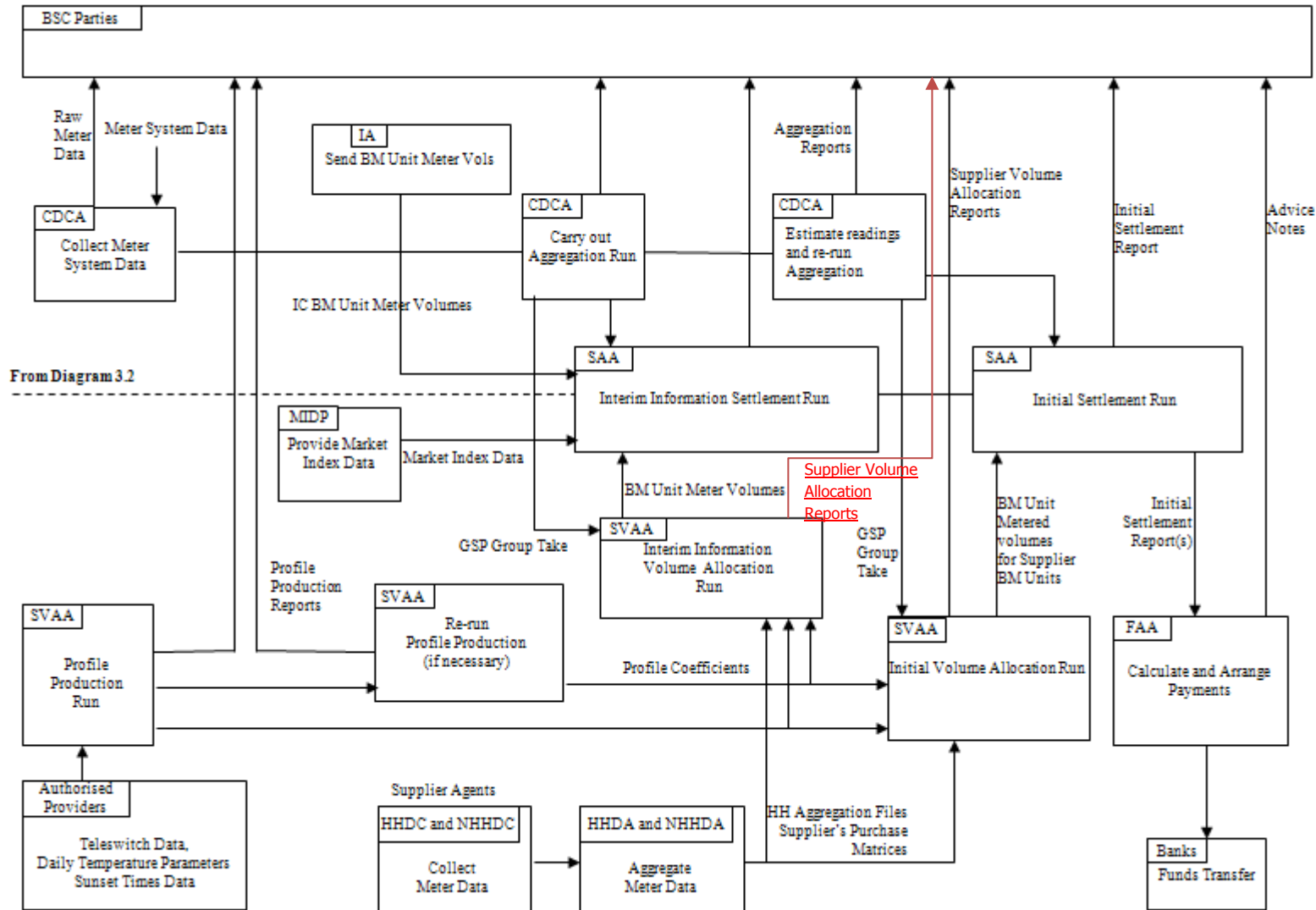

Amend Section 4.1 as follows:

4.1 Interim Information and Initial Settlement Timetable and Settlement Reports

This section covers the tasks required for the Interim Information and Initial Settlement Runs. The Interim Information run is carried out at approximately 5 WD, with no associated Payment Date. The Initial Settlement Run is carried out at approximately 16 WD, with an associated Payment Date of approximately 20 – 21 WD.

Ref	Task	Responsibility	Time-scale
1	Send to ECVAA: <ul style="list-style-type: none"> Energy Contract Volume Notifications 	ECVNA	To be received by ECVAA before Gate Closure
2	Send to ECVAA: <ul style="list-style-type: none"> Meter Volume Reallocation Notifications 	MVRNA	To be received by ECVAA before Gate Closure
3	Send the following information (for each BM Unit in respect of which the Lead Party is obliged to submit a FPN or has chosen to submit a FPN) to the TC: <ul style="list-style-type: none"> Final Physical Notification Data Quiescent Physical Notification Data (optional) Bid / Offer Data (Required only if trading in Balancing Mechanism) Dynamic Data 	Lead Parties	To be received by TC before Gate Closure
4	Send to BMRA: <ul style="list-style-type: none"> Market Index Data 	Market Index Data Providers	Target by end of Settlement Period
5	Accept Bids and Offers as required to meet forecast and actual system conditions. Acceptances which are taken to resolve transmission constraints are SO-Flagged.	TC	Not later than 15 minutes following the issue of an Acceptance; or In the case of an Emergency Instruction, as soon as reasonably practicable.
6	Energy Transfer and Metering	Lead Parties	Settlement Period

Ref	Task	Responsibility	Time-scale
7	<p>Send the following information to BMRA (for information / storage) for each BM Unit in respect of which the Lead Party is obliged to submit a FPN or has chosen to submit a FPN to the TC:</p> <ul style="list-style-type: none"> • Maximum Export Limit • Maximum Import Limit • Final Physical Notification Data • Quiescent Physical Notification Data (if submitted by Parties in step 3) • Dynamic Data • Bid Offer Data (for those BM Units for which such data has been provided) • Acceptance Data • System related Data • BM Unit Applicable Balancing Services Volume Data 	TC	<p>Target Times:</p> <p>Not later than 5 minutes following receipt</p> <p>Not later than 15 minutes following Gate closure for each Settlement Period</p> <p>Not later than 1200 hrs each day</p>
8	<p>Send Final Physical Notification Data to ECVAA.</p> <p>Calculate Indicative System Buy Price and Indicative System Sell Price and publish relevant data</p>	BMRA	<p>Upon receipt from TC.</p> <p>15 + CADL minutes after end of Settlement Period.</p>
9	<p>Send the following information to SAA to enable Settlement:</p> <ul style="list-style-type: none"> • Final Physical Notification Data • Quiescent Physical Notification Data (if available) • Balancing Services Adjustment Data • Bid Offer Data • Acceptance Data • Any Dynamic Data received by the TC during the Settlement Day • BM Unit Applicable Balancing Services Volume Data 	BMRA	<p>The next day following the Settlement Day for Balancing Services Adjustment Data, and by 15 minutes following the end of the Settlement Day for the other items.</p> <p>Within 2 Business Days following the relevant Settlement Period for BM Unit Applicable Balancing Services Volume Data</p>
10	<p>Interrogate Metering Systems registered by Parties with the CRA and collect consumption data.</p> <p>Send to relevant Parties:</p> <ul style="list-style-type: none"> • Raw Meter Data together with any validation criteria 	CDCA	Send out by Settlement Day +1 (1300hrs)
11	<p>Send to SVAA:</p> <ul style="list-style-type: none"> • Tele-switch data 	Tele-switch Agent	By +1 WD (by 1000hrs)

Ref	Task	Responsibility	Time-scale
12	Obtain the following data from relevant authorised providers: <ul style="list-style-type: none"> • Daily temperature parameters by GSP Group • Sunset times by GSP Group (annually) Perform Profile Production Run Send Profile Reports to Suppliers and NHHDCs	SVAA	By +1 WD (by 1000hrs) By +1 WD (by 1700hrs)
13	Send to the SAA: <ul style="list-style-type: none"> • BM Unit Metered Volumes for the BM Units of each Interconnector User for each Interconnector 	IA	By +1 WD
14	Send to SAA: <ul style="list-style-type: none"> • Market Index Data 	Market Index Data Providers	By +1 WD
15	Suppliers raise query on Daily Profile Production Reports if necessary and log with Dispute Administrator	Supplier	By +3 WD (by 1000hrs)
16	Resolve Daily Profile Production query	SVAA	By +4 WD (by 1300hrs)
17	Amend Profile variables ready to re-run Daily Profile Production, if necessary	SVAA	By +4 WD (by 1500hrs)
18	If re-run of Daily Profile Production required then carry this out and send revised Daily Profile Production Reports to relevant Suppliers	SVAA	By +4 WD (by 1730hrs)
19	Collate information for use in the Interim Information Run Send to SAA: <ul style="list-style-type: none"> • Meter Volume Reallocation Notification, by BM Unit for each Settlement Period • Account Bilateral Contract Volumes for each Settlement Period by BSC Party 	ECVAA	In accordance with SAA Settlement Calendar

Ref	Task	Responsibility	Time-scale
20	<p>Carry out CDCA Aggregation for Interim Information Volume Allocation Run using the latest available data, i.e. valid actual meter data and/or agreed estimated meter data (for all missing or invalid readings) and the latest available approved Line Loss Factors, Aggregation Rules, Registration Data and Meter Technical Details.</p> <p>Send to SAA:</p> <ul style="list-style-type: none"> • BM Unit Metered Volumes for each BM Unit • GSP Group Take • Interconnector Metered Volumes <p>Send to SVAA:</p> <ul style="list-style-type: none"> • GSP Group Take <p>Send to BSC Parties:</p> <ul style="list-style-type: none"> • GSP Group Take <p>Send to Lead Party and TC</p> <ul style="list-style-type: none"> • BM Unit Aggregation Report 	CDCA	By + 4 WD (0900hrs)
21	<p>Ensure Agents send to SVAA:</p> <ul style="list-style-type: none"> • Half Hourly Aggregation Files from HHDAs • Supplier Purchase Matrices from NHDAs 	Suppliers	By +4 WD (0900hrs)
22	<p>Carry out Interim Information Volume Allocation Run</p> <p>Calculate the Supplier Volume Allocations for each BM Unit</p>	SVAA	By +4 WD (from 0900hrs)
23	<p>Send to SAA:</p> <p>BM Unit Metered volumes for Supplier BM Units</p>	SVAA	For receipt by + 5 WD (0900hrs)
<u>24</u>	<p><u>Send Interim Information Volume Allocation Run Reports to relevant Suppliers</u></p>	<u>SVAA</u>	<u>By +5 WD</u>
<u>245</u>	<p>Carry out Interim Information Settlement Run using data from CDCA, ECVA, SVAA, TC and MIDPs and send relevant reports to Parties.</p> <p>Issue IIR Credits/Debits Report to ECVA.</p>	SAA	By + 5 WD or later if delayed in accordance with the Code

Ref	Task	Responsibility	Time-scale
<u>256</u>	Implement SVAA resolution on profile query or request arbitration from Disputes Administrator	Supplier	By + 5 WD (by 1600hrs)
<u>267</u>	Communicate outcome of arbitration to affected Suppliers and SVAA	Dispute Administrator	By +7 WD (by 1000hrs)
<u>278</u>	If arbitration against SVAA, amend profile variables ready to re-run Daily Profile Production	SVAA	By +7 WD (by 1430hrs)
<u>289</u>	Implement results from arbitration and send revised profiles to affected Suppliers	SVAA	By +7 WD (by 1800hrs)
<u>2930</u>	<p>Estimate volumes for missing or disputed data in accordance with the Code.</p> <p>Carry out CDCA Aggregation for Initial Volume Allocation Run using the latest available data i.e. valid actual meter readings and/or any agreed estimates and the latest available approved Line Loss Factors, Aggregation Rules, Registration Data and Meter Technical Details.</p> <p>Send to Parties:</p> <ul style="list-style-type: none"> • GSP Group Take <p>Send to Lead Party and TC</p> <ul style="list-style-type: none"> • BM Unit Aggregation Report <p>Send to SVAA:</p> <ul style="list-style-type: none"> • GSP Group Take <p>Send to SAA:</p> <ul style="list-style-type: none"> • CDCA Aggregation File 	CDCA	For receipt by +14 WD
<u>301</u>	<p>Ensure Agents send to SVAA:</p> <ul style="list-style-type: none"> • Half Hourly Aggregation Files from HHDAs • Supplier Purchase Matrices from NHDAs 	Suppliers	By +14 WD
<u>342</u>	<p>Carry out Initial Volume Allocation Run</p> <p>Calculate the Supplier Volume Allocations for each BM Unit</p>	SVAA	By +15 WD (from 0900hrs)
<u>323</u>	<p>Send to SAA:</p> <ul style="list-style-type: none"> • BM Unit Metered volumes for Supplier BM Units 	SVAA	For receipt by + 16 WD (0900hrs)

Ref	Task	Responsibility	Time-scale
334	Send: <ul style="list-style-type: none"> Relevant Reports to TC DUoS Report to Distribution Businesses Initial Volume Allocation Run Reports to Suppliers 	SVAA	By + 16 WD (before 1230hrs)))By + 17 WD)
345	Carry out Initial Settlement Run using latest files from TC, ECVAA, CDCA and SVAA and MIDPs; and send relevant reports to BSC Parties. Send Settlement Report to FAA	SAA	By +16 WD (subject to SAA Settlement Calendar) or later if delayed in accordance with the Code For receipt by + 17 WD (0900hrs) (subject to Payment Calendar)
356	Receive Settlement Report from SAA Calculate Payments	FAA	By +17–18 WD (subject to Payment Calendar)
367	Send Advice Notes to Payment Parties	FAA	By +17–18 WD (subject to Payment Calendar)
378	Funds transfers between Parties' Banks	FAA	By +20–21 WD (subject to Payment Calendar)